



PROPRIETARY NOTE

THIS SPECIFICATION IS THE PROPERTY OF BOE HYDIS AND SHALL NOT BE REPRODUCED OR COPIED WITHOUT THE WRITTEN PERMISSION OF BOE HYDIS AND MUST BE RETURNED TO BOE HYDIS UPON ITS REQUEST

TITLE : HT12X21-351
Product Specification for Lenovo
Rev. D

BOE HYDIS TECHNOLOGY

SPEC. NUMBER S864-1216	PRODUCT GROUP TFT-LCD PRODUCTS	REV. D	ISSUE DATE 2006. 09. 11	PAGE 1 OF 27
---------------------------	-----------------------------------	-----------	----------------------------	-----------------

**PRODUCT GROUP**

REV

ISSUE DATE

TFT LCD PRODUCT

D

2006. 09. 11

Contents

No	Item	Page
1.0	General Description	4
2.0	Absolute Maximum ratings	5
3.0	Electrical specifications.	6
4.0	Optical specifications.	8
5.0	Interface Connection	10
6.0	Signal Timing Specification	12
7.0	Signal Timing waveforms of interface signal (DE Mode)	14
8.0	Input Signals, Display Colors & Gray Scale of Colors	15
9.0	Power Sequence	16
10.0	Mechanical Characteristics	17
11.0	Reliability Test	18
12.0	Handling & Cautions.	19
13.0	Packing	20
14.0	Label	21
15.0	Appendix	23
	Outline drawing (Front & Rear)	25

SPEC. NUMBER
S864-1216SPEC TITLE
HT12X21-351 Product specification for LenovoPAGE
3 OF 27

1.0 GENERAL DESCRIPTION

1.1 Introduction

12.1"XGA is a color active matrix TFT LCD module using AFFS(Advanced Fringe Field Switching: Wide viewing technology) mode and amorphous silicon TFT's (Thin Film Transistors) as an active switching devices. This module has a 12.1 inch diagonally measured active area with XGA resolutions (1024 horizontal by 768 vertical pixel array). Each pixel is divided into RED, GREEN, BLUE dots which are arranged in vertical stripe and this module can display 262,144 colors. The TFT-LCD panel used for this module is a low reflection and higher color type.

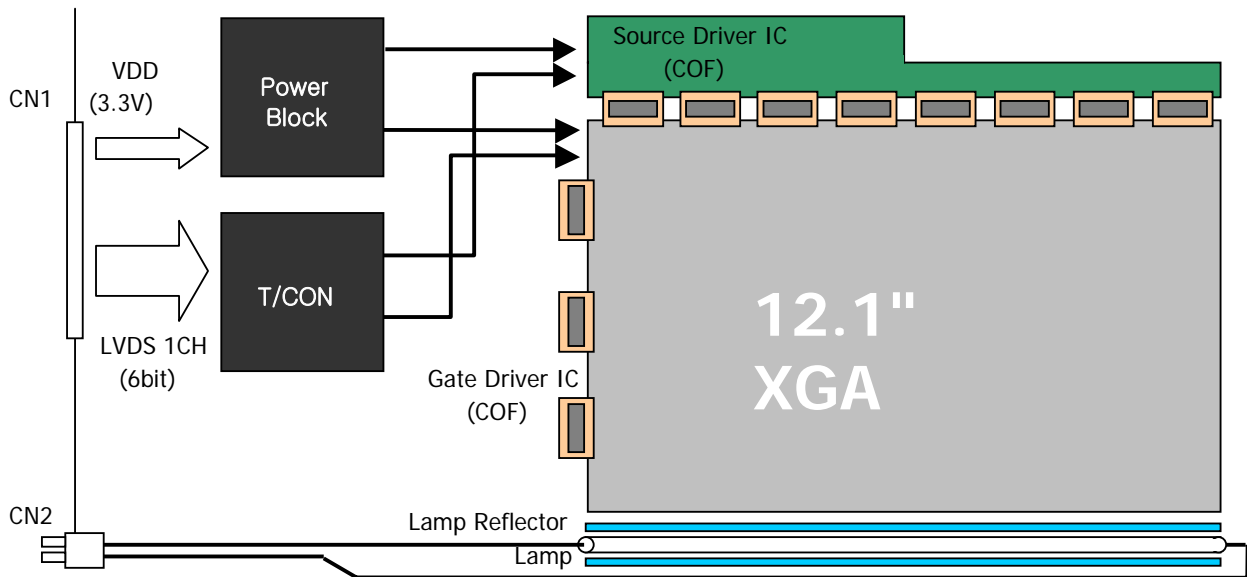

1.2 Features

- LVDS Interface with 1pixel / clock
- High-speed response
- 6-bit color depth, Display 262,144 colors
- Incorporated edge type back-light (1 lamp)
- High luminance and contrast ratio, low reflection and wide viewing angle
- DE (Data Enable) mode only
- RoHS

1.3 Applications

- Pen-type & Tablet PC

**PRODUCT GROUP**

REV

ISSUE DATE

TFT LCD PRODUCT

D

2006. 09. 11

1.4 General Specification

The followings are general specifications at the model HT12X21-351

Parameter	Specification	Unit	Remarks
Active area	245.76 X 184.32	mm	
Number of pixels	1024(H) X 768(V)	pixels	
Pixel pitch	0.240(H) X 0.240(V)	mm	
Pixel arrangement	RGB Vertical stripe		
Display colors	262,144	colors	
Display mode	Normally Black		
Dimensional outline	270.0+/-0.5(H) X 199.0+/-0.3(V) X 4.8 +/-0.3 @ Lamp, 6.7+/-0.3 @Pouch	mm	Note 2
Weight	305 typ.	g	
Back-light	Bottom edge side 1-CCFL type		Note 1

Note 1. CCFL (Cold Cathode Fluorescent Lamp)

2. LCM Height 4.8 [mm] Typical (lamp), 6.7[mm] Typical (Pouch)

SPEC. NUMBER
S864-1216SPEC TITLE
HT12X21-351 Product specification for LenovoPAGE
5 OF 27



PRODUCT GROUP

REV

ISSUE DATE

TFT LCD PRODUCT

D

2006. 09. 11

2.0 ABSOLUTE MAXIMUM RATINGS

The followings are maximum values which, if exceed, may cause faulty operation or damage to the unit.

VSS = GND = 0V

Parameter	Symbol	Min.	Max.	Unit	Remarks
Power Supply Voltage	V_{DD}	-0.3	4.0	V	
Logic Supply Voltage	V_{IN}	-0.3	$V_{DD}+0.3$	V	
Lamp Current	I_{BL}	2.0	6.0	mArms	Note 1
Lamp frequency	F_L	30	80	kHz	Note 1
Operating Temperature (Humidity)	T_{OP} RH	0	+50 80	°C %	Note 2
Storage Temperature (Humidity)	T_{SP} RH	-20	+60 90	°C %	Note 2

- Note 1. Permanent damage to the device may occur if maximum values are exceeded Functional operation should be restricted to the condition described under normal operating conditions.
2. Temperature and relative humidity range are shown in the figure below.
 95 % RH Max. ($40\text{ }^{\circ}\text{C} \geq T_a$)
 Maximum wet - bulb temperature at $39\text{ }^{\circ}\text{C}$ or less. ($T_a > 40\text{ }^{\circ}\text{C}$) No condensation.

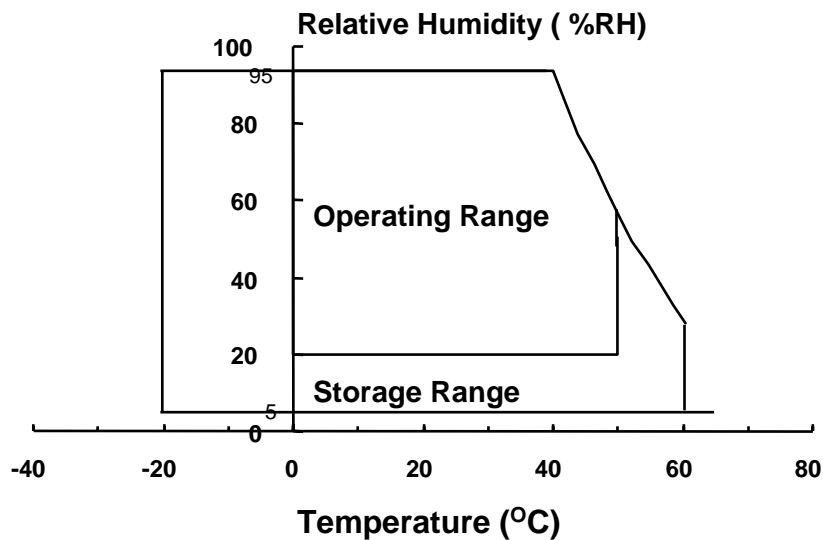

SPEC. NUMBER
S864-1216

SPEC TITLE
HT12X21-351 Product specification for Lenovo

PAGE
6 OF 27



PRODUCT GROUP

REV

ISSUE DATE

TFT LCD PRODUCT

D

2006. 09. 11

3.0 ELECTRICAL SPECIFICATIONS

[Ta = 25± 2℃]

Parameter		Min.	Typ.	Max.	Unit	Remarks	
Power Supply Voltage	V _{DD}	3.0	3.3	3.6	V		
Power Supply Current	I _{DD}	-	240	-	mA	Note 1	
CCFL Ignition Time	t	-	-	1.0	sec		
Permissible Input Ripple Voltage	V _{RF}	-	-	100	mV	At V _{DD} = 3.3V	
High Level Differential Input Signal Voltage	V _{IH}	-	-	+ 100	mV	V _{cm} = 1.2 V Typ	
Low Level Differential Input Signal Voltage	V _{IL}	- 100	-	-	mV		
Back-light Lamp Voltage	V _{BL}	-	600	-	V _{rms}		
Back-light Lamp Current	I _{BL}	2.0	5.0	6.0	mA		
Back-light Lamp operating Frequency	F _L	40	60	80	KHz	Note 2	
Lamp Start Voltage		1040	-	-	V _{rms}	25 °C, Note 3	
		1300	-	-	V _{rms}	0 °C, Note 3	
Lamp Life		12,000	-	-	Hrs	I _{BL} = 2.0~6.0 mA	
Power Consumption		P _D	-	0.7	1.1	W	
		P _{BL}	-	3.0	3.5	W	I _{BL} = 5.0 mA Note 4
		P _{total}	-	3.7	4.6	W	

SPEC. NUMBER
S864-1216

SPEC TITLE
HT12X21-351 Product specification for Lenovo

PAGE
7 OF 27

**PRODUCT GROUP**

REV

ISSUE DATE

TFT LCD PRODUCT

D

2006. 09. 11

Notes :

1. The supply voltage is measured and specified at the interface connector of LCM.
The current draw and power consumption specified is for VDD = 3.3V, Frame rate = 60 Hz and Clock frequency = 65MHz.
Test Pattern of power supply current
 - a) Typ : Vertical color bar pattern
 - b) Max : Gray 28 @ Vertical 2 Skip line pattern
2. The lamp frequency should be selected as different as possible from the horizontal synchronous frequency and its harmonics to avoid interference, which may cause line flow on the display.
3. For starting the backlight unit, the output voltage of DC/AC's transformer should be larger than the minimum lamp starting voltage.(1,040 Vrms at 25 °C & 1,300 Vrms at 0 °C).
If an inverter has shutdown function it should keep its output for more than 1 second even if the lamp connector open. Otherwise the lamps may not to be turned on.
4. Calculated value for reference (VBL × IBL) excluding inverter loss.

SPEC. NUMBER
S864-1216SPEC TITLE
HT12X21-351 Product specification for LenovoPAGE
8 OF 27



PRODUCT GROUP

REV

ISSUE DATE

TFT LCD PRODUCT

D

2006. 09. 11

4.0 OPTICAL SPECIFICATION

The measurement shall be executed after 30 minutes warm-up period.

Measuring equipment: TOPCON-BM5.

[VDD=3.3V, Frame rate=60Hz, Clock=65MHz, $I_{BL} = 5.0\text{mA}$, $T_a = 25 \pm 2^\circ\text{C}$]

Parameter		Symbol	Condition	Min.	Typ.	Max.	Unit	Remarks
Viewing Angle range	Horizontal	Θ_3	CR > 10	-	80	-	Deg.	Note 1
		Θ_9		-	80	-	Deg.	
	Vertical	Θ_{12}		-	80	-	Deg.	
		Θ_6		-	80	-	Deg.	
Luminance Contrast ratio		CR		-	450	-		Note 2
Center Luminance of White		Y_w		150	165	-	cd/m ²	Note 3
White Luminance uniformity		$\Delta Y5$		80	-	-	%	Note 4
		$\Delta Y13$		65	-	-	%	
White Chromaticity		x_w		0.285	0.313	0.341		Note 5
		y_w		0.309	0.329	0.349		
Reproduction of color	Red	x_R		0.543	0.573	0.603		
		y_R		0.303	0.333	0.363		
	Green	x_G		0.278	0.308	0.338		
		y_G		0.507	0.537	0.567		
	Blue	x_B		0.120	0.150	0.180		
		y_B		0.108	0.138	0.168		
Color reproduction				-	45	-	%	
Response Time	Total (Td+Tr)		$\Theta = 0^\circ$	-	40	-	ms	
Cross Talk	CT			-	-	2.0	%	Note 7

SPEC. NUMBER
S864-1216

SPEC TITLE
HT12X21-351 Product specification for Lenovo

PAGE
9 OF 27



PRODUCT GROUP

REV

ISSUE DATE

TFT LCD PRODUCT

D

2006. 09. 11

Notes :

1. Viewing angle is the angle at which the contrast ratio is greater than 10. The viewing are determined for the horizontal or 3, 9 o'clock direction and the vertical or 6, 12 o'clock direction with respect to the optical axis which is normal to the LCD surface.
(see FIGURE 1).
2. Contrast measurements shall be made at viewing angle of $\Theta = 0^\circ$ and at the center of the LCD surface. Luminance shall be measured with all pixels in the view field set first to white, then to the dark (black) state. (See FIGURE 1) Luminance Contrast Ratio (CR) is defined mathematically.

$$CR = \frac{\text{Luminance when displaying a white raster}}{\text{Luminance when displaying a black raster}}$$
3. Luminance of white is defined as a center point(#1) on LCD surface. Luminance shall be measured with all pixels in the view field set first to white. This measurement shall be taken at the locations shown in FIGURE 2 for a total of the measurements per display.
4. The White luminance uniformity on LCD surface is then expressed as : $\Delta Y = \text{Minimum Luminance of 5 points (L1 ~ L5)} / \text{Maximum Luminance of 5 points (L1 ~ L5)}$ and $\text{Minimum Luminance of 13 points (L1 ~ L13)} / \text{Maximum Luminance of 13 points (L1 ~ L13)}$
(see FIGURE 2)
5. The color chromaticity coordinates specified in Table 4 shall be calculated from the spectral data measured with all pixels first in red, green, blue and white. Measurements shall be made at the center of the panel.
6. The electro-optical response time measurements shall be made as FIGURE 3 by switching the "data" input signal ON and OFF. The times needed for the luminance to change from 10% to 90% is T_r , and 90% to 10% is T_d .
7. Cross-Talk of one area of the LCD surface by another shall be measured by comparing the luminance (YA) of a 25mm diameter area, with all display pixels set to a gray level, to the luminance (YB) of that same area when any adjacent area is driven dark.
(See FIGURE 4)

SPEC. NUMBER
S864-1216

SPEC TITLE
HT12X21-351 Product specification for Lenovo

PAGE
10 OF 27

**PRODUCT GROUP**

REV

ISSUE DATE

TFT LCD PRODUCT

D

2006. 09. 11

5.0 INTERFACE CONNECTION.**5.1 Electrical Interface Connection**

CN 1 : Interface connector : DF19L-20P-1H (Hirose)

User side connector : DF19G-20S-1C (Hirose)

Terminal	Symbol	Functions	Remarks
1	VDD	Power supply +3.3 V	
2	VDD	Power supply +3.3 V	
3	VSS	Ground	
4	VSS	Ground	
5	RIN0 -	LVDS Negative data signal (-)	Tx pin #48
6	RIN0 +	LVDS Positive data signal (+)	Tx pin #47
7	VSS	Ground	
8	RIN1 -	LVDS Negative data signal (-)	Tx pin #46
9	RIN1 +	LVDS Positive data signal (+)	Tx pin #45
10	VSS	Ground	
11	RIN2 -	LVDS Negative data signal (-)	Tx pin #42
12	RIN2 +	LVDS Positive data signal (+)	Tx pin #41
13	VSS	Ground	
14	RCLKIN -	LVDS Negative clock signal (-)	Tx pin #40
15	RCLKIN +	LVDS Positive clock signal (+)	Tx pin #39
16	VSS	Ground	
17	NC	No Connection	
18	NC	No Connection	
19	VSS	Ground	
20	VSS	Ground	

SPEC. NUMBER
S864-1216SPEC TITLE
HT12X21-351 Product specification for LenovoPAGE
11 OF 27



PRODUCT GROUP

REV

ISSUE DATE

TFT LCD PRODUCT

D

2006. 09. 11

5.2. Back-light Interface

The Back-light interface connector is a model BHSR-02VS-1 manufactured by JST or equivalent.

Pin No.	Symbol	Function	Color
1	HOT	High voltage	Pink
2	COLD	Ground	White

5.3. LVDS Interface

LVDS Transmitter THC63LVDM83A or equivalent.

Input Signal	Transmitter		Interface		DF19L-20P-1H	Remarks
	Pin No.	Pin No.	System (Tx)	TFT-LCD (Rx)	Pin No.	
R0	51	48 47	OUT0 - OUT0 +	IN0 - IN0 +	5 6	
R1	52					
R2	54					
R3	55					
R4	56					
R5	3					
G0	4	46 45	OUT1 - OUT1 +	IN1 - IN1 +	8 9	
G1	6					
G2	7					
G3	11					
G4	12					
G5	14					
B0	15	42 41	OUT2 - OUT2 _+	IN2 - IN2 +	11 12	
B1	19					
B2	20					
B3	22					
B4	23					
B5	24					
HSYNC	27	40	CLKOUT -	CLKIN -	14	
VSYNC	28					
DE	30					
MCLK	31	39	CLKOUT +	CLKIN +	15	

SPEC. NUMBER
S864-1216

SPEC TITLE
HT12X21-351 Product specification for Lenovo

PAGE
12 OF 27



PRODUCT GROUP

REV

ISSUE DATE

TFT LCD PRODUCT

D

2006. 09. 11

5.4. Data input Format

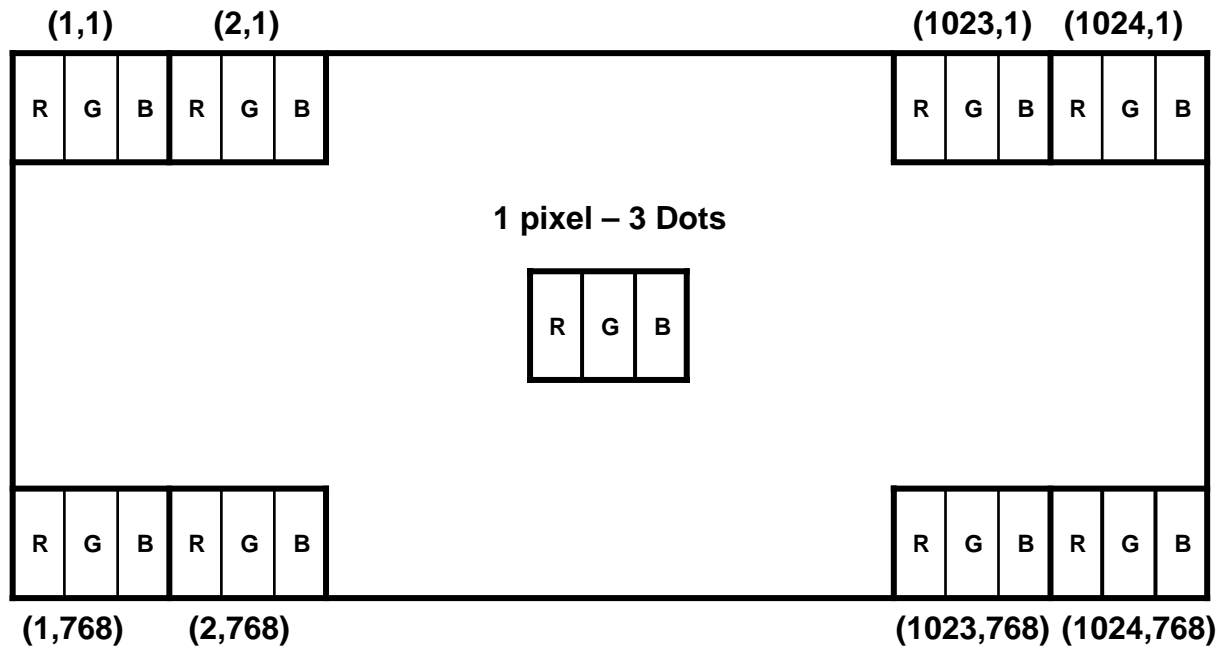

Display position of input data

6.0. SIGNAL TIMING SPECIFICATION

6.1 The 12.1" XGA LCM is operated by the only DE (Data enable) mode (LVDS Transmitter Input)

Item		Symbols	Min	Typ	Max	Unit
Clock	Frequency	1/Tc	-	65	80	MHz
	High Time	Tch	4.5	-	-	ns
	Low Time	Tcl	4.5	-	-	ns
Data	Setup Time	Tds	2.7	-	-	ns
	Hold Time	Tdh	0	-	-	ns
Data Enable Setup Time		Tes	2.7	-	-	ns
Frame Period		Tv	772	806	1022	lines
Vertical Display Period		Tvd	768	768	768	lines
One Line Scanning Period		Th	1100	1344	2046	clocks
Horizontal Display Period		Thd	1024	1024	1024	clocks

SPEC. NUMBER
S864-1216

SPEC TITLE
HT12X21-351 Product specification for Lenovo

PAGE
13 OF 27

6.2 LVDS Rx Interface timing parameter

The specification of the LVDS Rx interface timing parameter

<LVDS Rx Interface Timing Specification>

Item	Symbol	Min	Typ	Max	Unit	Remarks
CLKIN Period	tRIPC	12.50	15.38	-	ns	
Input Data 0	tRIP0	-0.4	0.0	+0.4	ns	
Input Data 1	tRIP1	tRIPC/7-0.4	tRIPC/7	tRIPC/7+0.4	ns	
Input Data 2	tRIP2	2xtRIPC/7-0.4	2xtRIPC/7	2xtRIPC/7+0.4	ns	
Input Data 3	tRIP3	3xtRIPC/7-0.4	3xtRIPC/7	3xtRIPC/7+0.4	ns	
Input Data 4	tRIP4	4xtRIPC/7-0.4	4xtRIPC/7	4xtRIPC/7+0.4	ns	
Input Data 5	tRIP5	5xtRIPC/7-0.4	5xtRIPC/7	5xtRIPC/7+0.4	ns	
Input Data 6	tRIP6	6xtRIPC/7-0.4	6xtRIPC/7	6xtRIPC/7+0.4	ns	

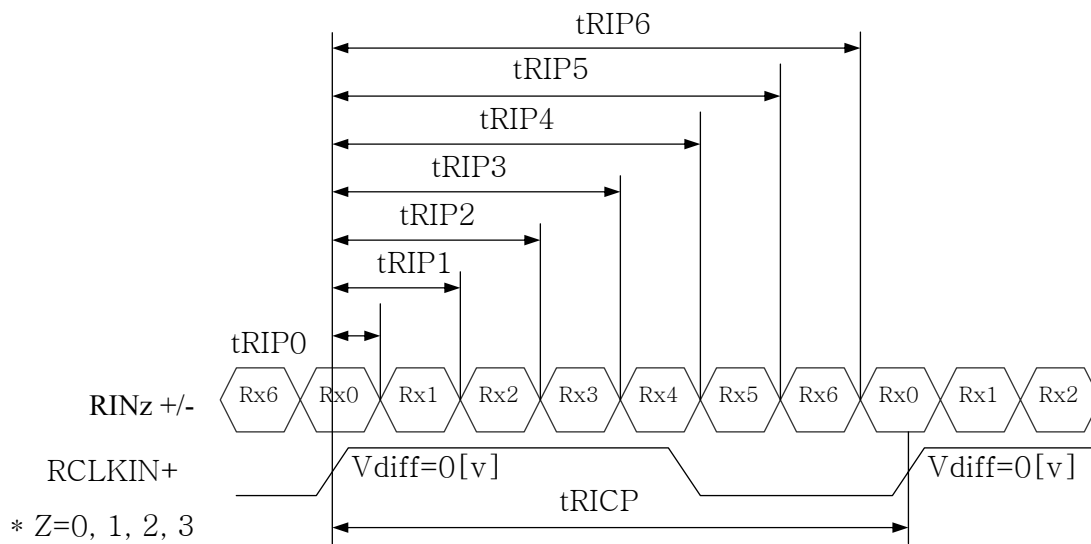

* $V_{diff} = (RINz+) - (RINz-), (RCLKIN+) - (RCLKIN-)$

7.0 SIGNAL TIMING WAVEFORMS

Timing wave forms of interface signal

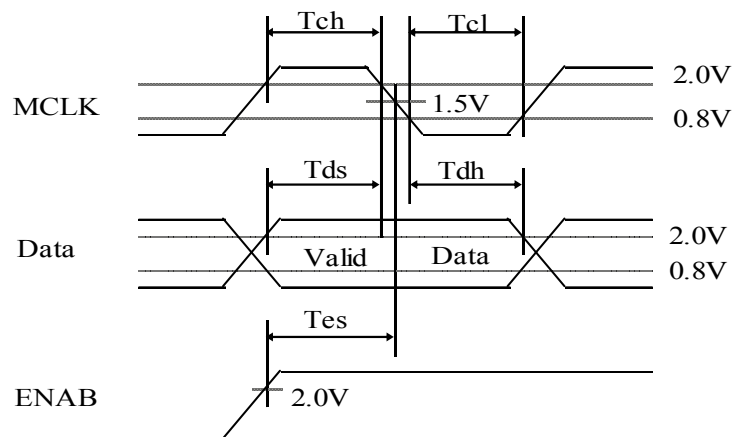
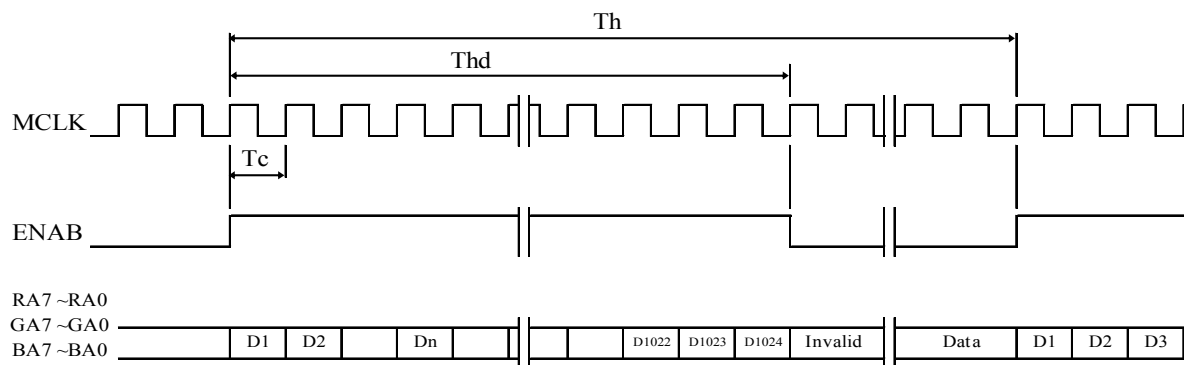
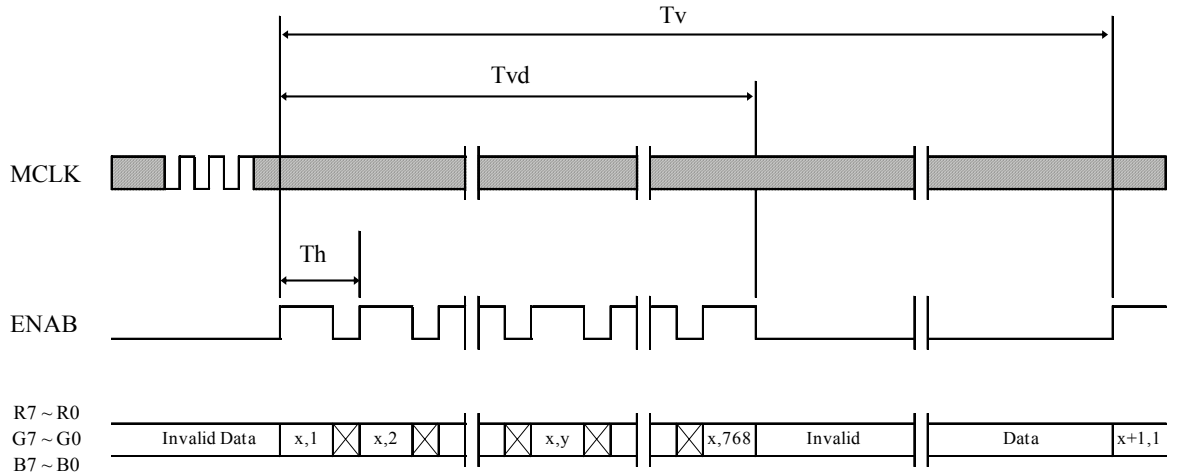



PRODUCT GROUP

REV

ISSUE DATE

TFT LCD PRODUCT

D

2006. 09. 11

8.0 INPUT SIGNALS, BASIC DISPLAY COLORS & GRAY SCALE OF COLORS

	Colors & Gray scale	Data signal																	
		R0	R1	R2	R3	R4	R5	G0	G1	G2	G3	G4	G5	B0	B1	B2	B3	B4	B5
Basic colors	Black	0	0	0	0	0	0	0	0	0	0	0	0	0	0	0	0	0	0
	Blue	0	0	0	0	0	0	0	0	0	0	0	0	1	1	1	1	1	1
	Green	0	0	0	0	0	0	1	1	1	1	1	1	0	0	0	0	0	0
	Light Blue	0	0	0	0	0	0	1	1	1	1	1	1	1	1	1	1	1	1
	Red	1	1	1	1	1	1	0	0	0	0	0	0	0	0	0	0	0	0
	Purple	1	1	1	1	1	1	0	0	0	0	0	0	1	1	1	1	1	1
	Yellow	1	1	1	1	1	1	1	1	1	1	1	1	0	0	0	0	0	0
	White	1	1	1	1	1	1	1	1	1	1	1	1	1	1	1	1	1	
Gray scale of Red	Black	0	0	0	0	0	0	0	0	0	0	0	0	0	0	0	0	0	0
	△	1	0	0	0	0	0	0	0	0	0	0	0	0	0	0	0	0	0
	Darker	0	1	0	0	0	0	0	0	0	0	0	0	0	0	0	0	0	0
	△				↓						↓						↓		
	▽				↓						↓						↓		
	Brighter	1	0	1	1	1	1	0	0	0	0	0	0	0	0	0	0	0	0
	▽	0	1	1	1	1	0	0	0	0	0	0	0	0	0	0	0	0	
	Red	1	1	1	1	1	1	1	1	1	1	1	0	0	0	0	0	0	0
Gray scale of Green	Black	0	0	0	0	0	0	0	0	0	0	0	0	0	0	0	0	0	0
	△	0	0	0	0	0	0	1	0	0	0	0	0	0	0	0	0	0	0
	Darker	0	0	0	0	0	0	0	1	0	0	0	0	0	0	0	0	0	0
	△				↓						↓						↓		
	▽				↓						↓						↓		
	Brighter	0	0	0	0	0	0	1	0	1	1	1	1	0	0	0	0	0	0
	▽	0	0	0	0	0	0	1	1	1	1	1	0	0	0	0	0	0	
	Green	0	0	0	0	0	1	1	1	1	1	1	0	0	0	0	0	0	0
Gray scale of Blue	Black	0	0	0	0	0	0	0	0	0	0	0	0	0	0	0	0	0	0
	△	0	0	0	0	0	0	0	0	0	0	0	0	1	0	0	0	0	0
	Darker	0	0	0	0	0	0	0	0	0	0	0	0	0	1	0	0	0	0
	△				↓						↓						↓		
	▽				↓						↓						↓		
	Brighter	0	0	0	0	0	0	0	0	0	0	0	0	1	0	1	1	1	1
	▽	0	0	0	0	0	0	0	0	0	0	0	0	1	1	1	1	1	
	Blue	0	0	0	0	0	0	0	0	0	0	0	1	1	1	1	1	1	
Gray scale of White & Black	Black	0	0	0	0	0	0	0	0	0	0	0	0	0	0	0	0	0	0
	△	1	0	0	0	0	0	1	0	0	0	0	0	1	0	0	0	0	0
	Darker	0	1	0	0	0	0	0	1	0	0	0	0	0	1	0	0	0	0
	△				↓						↓						↓		
	▽				↓						↓						↓		
	Brighter	1	0	1	1	1	1	1	0	1	1	1	1	1	0	1	1	1	1
	▽	0	1	1	1	1	1	0	1	1	1	1	1	0	1	1	1	1	
	White	1	1	1	1	1	1	1	1	1	1	1	1	1	1	1	1	1	1

SPEC. NUMBER
S864-1216

SPEC TITLE
HT12X21-351 Product specification for Lenovo

PAGE
16 OF 27

9.0 POWER SEQUENCE

To prevent a latch-up or DC operation of the LCD module, the power on/off sequence shall be as shown in below

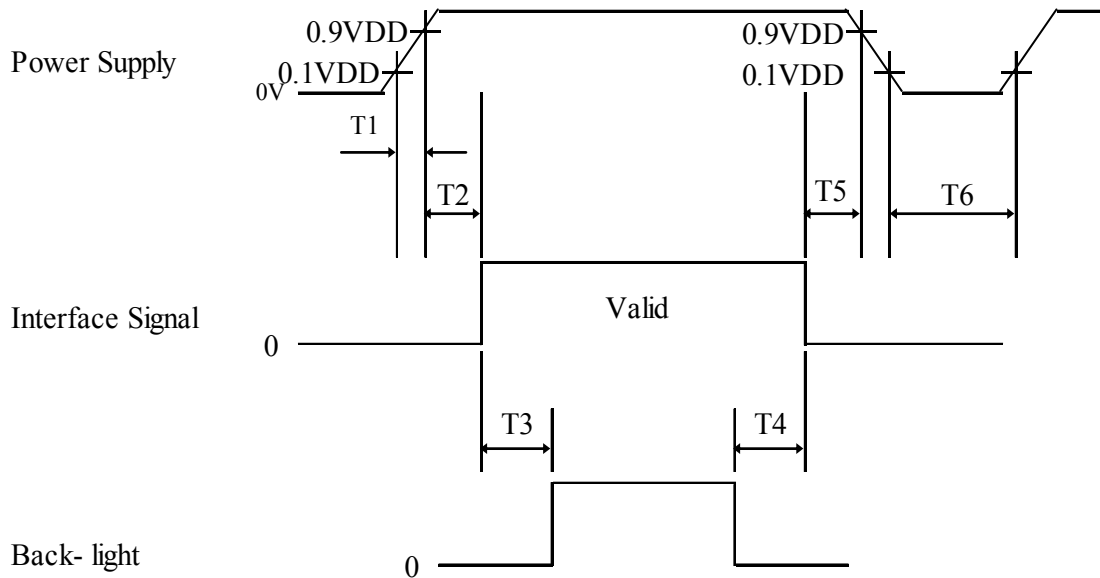

- $0 < T1 \leq 10 \text{ ms}$
- $0 < T2 \leq 50 \text{ ms}$
- $200 \text{ ms} \leq T3$
- $0 \text{ ms} \leq T4, 0 \text{ ms} \leq T5$
- $0 \leq T6 \leq 10\text{ms}$
- $150\text{ms} \leq T7$

- Notes :
1. When the power supply VDD is 0V, Keep the level of input signals on the low or keep high impedance.
 2. Do not keep the interface signal high impedance when power is on.
 3. Back Light must be turn on after power for logic and interface signal are valid.



PRODUCT GROUP

REV

ISSUE DATE

TFT LCD PRODUCT

D

2006. 09. 11

10.0 MECHANICAL CHARACTERISTICS

10.1 Dimensional Requirements

FIGURE 5, 6 shown in appendix shows mechanical outlines for the model.

Parameter	Specification	Unit
Dimensional outline Horizontal Vertical Thickness	270.0 ± 0.5 199.0 ± 0.3 4.8+/-0.3 @ Lamp, 6.7+/-0.3 @ Pouch	mm
Weight	305 Typ	gram
Active Area	245.76 (H) X 184.32 (V)	mm
Pixel Pitch	0.240 (H) X 0.240 (V)	mm
Number of Pixels	1024 (H) X 768 (V)	pixels

10.2 Mounting

See FIGURE 5. (shown in Appendix)

10.3 Anti-Glare and Polarizer Hardness.

The surface of the LCD has an anti-glare coating to minimize reflection and a coating to reduce scratching.

10.4 Light Leakage

There shall not be visible light from the back-lighting system around the edges of the screen as seen from a distance 50cm from the screen with an overhead light level of 350lux.

SPEC. NUMBER
S864-1216

SPEC TITLE
HT12X21-351 Product specification for Lenovo

PAGE
18 OF 27

**PRODUCT GROUP**

REV

ISSUE DATE

TFT LCD PRODUCT

D

2006. 09. 11

11.0 RELIABILITY TEST

The Reliability test items and its conditions are shown in below.

No	Test Items	Conditions
1	High temperature storage test	Ta = 60 °C, 240 hrs
2	Low temperature storage test	Ta = -20 °C, 240 hrs
3	High temperature & high humidity operation test	Ta = 50 °C, 80~85%RH, 1000 hrs
4	Life Test	Ta = 25 °C, 1000 hrs
5	High temperature operation test	Ta = 50 °C, 240 hrs
6	Low temperature operation test	Ta = 0 °C, 240 hrs
7	On/Off test	Ta = 25°C, 1 min, On/Off 30000 cycles
8	Thermal shock	Ta = -20 °C ↔ 60 °C (30 min), 100 cycle
9	Vibration test (non-operating)	1.5G, 10~200Hz for X,Y,Z axis 30 min for each axis
10	Shock test (non-operating)	210 G, 3 msec, half sine for X, Y, Z axis 50G, 18 msec, trapezoidal for X, Y, Z axis
11	Altitude Test	53.3 Kpa (Altitude 5000m), 24 hrs
12	Open / Short Test	DS158, Open/Short Test Plan
13	Electro-static discharge test (non-operating)	Air : 150 pF, 330Ω, 15 KV Contact : 150 pF, 330Ω, 8 KV

SPEC. NUMBER
S864-1216SPEC TITLE
HT12X21-351 Product specification for LenovoPAGE
19 OF 27



PRODUCT GROUP

REV

ISSUE DATE

TFT LCD PRODUCT

D

2006. 09. 11

12.0 HANDLING & CAUTIONS

(1) Cautions when taking out the module

- Pick the pouch only, when taking out module from a shipping package.

(2) Cautions for handling the module

- As the electrostatic discharges may break the LCD module, handle the LCD module with care. Peel a protection sheet off from the LCD panel surface as slowly as possible.
- As the LCD panel and back - light element are made from fragile glass material, impulse and pressure to the LCD module should be avoided.
- As the surface of the polarizer is very soft and easily scratched, use a soft dry cloth without chemicals for cleaning.
- Do not pull the interface connector in or out while the LCD module is operating.
- Put the module display side down on a flat horizontal plane.
- Handle connectors and cables with care.

(3) Cautions for the operation

- When the module is operating, do not lose CLK, ENAB signals. If any one of these signals is lost, the LCD panel would be damaged.
- Obey the supply voltage sequence. If wrong sequence is applied, the module would be damaged.

(4) Cautions for the atmosphere

- Dew drop atmosphere should be avoided.
- Do not store and/or operate the LCD module in a high temperature and/or humidity atmosphere. Storage in an electro-conductive polymer packing pouch and under relatively low temperature atmosphere is recommended.

(5) Cautions for the module characteristics

- Do not apply fixed pattern data signal to the LCD module at product aging.
- Applying fixed pattern for a long time may cause image sticking.

(6) Other cautions

- Do not disassemble and/or re-assemble LCD module.
- Do not re-adjust variable resistor or switch etc.
- When returning the module for repair or etc., Please pack the module not to be broken. We recommend to use the original shipping packages.

SPEC. NUMBER
S864-1216

SPEC TITLE
HT12X21-351 Product specification for Lenovo

PAGE
20 OF 27

13.0 Packing

13.1 Packing Order

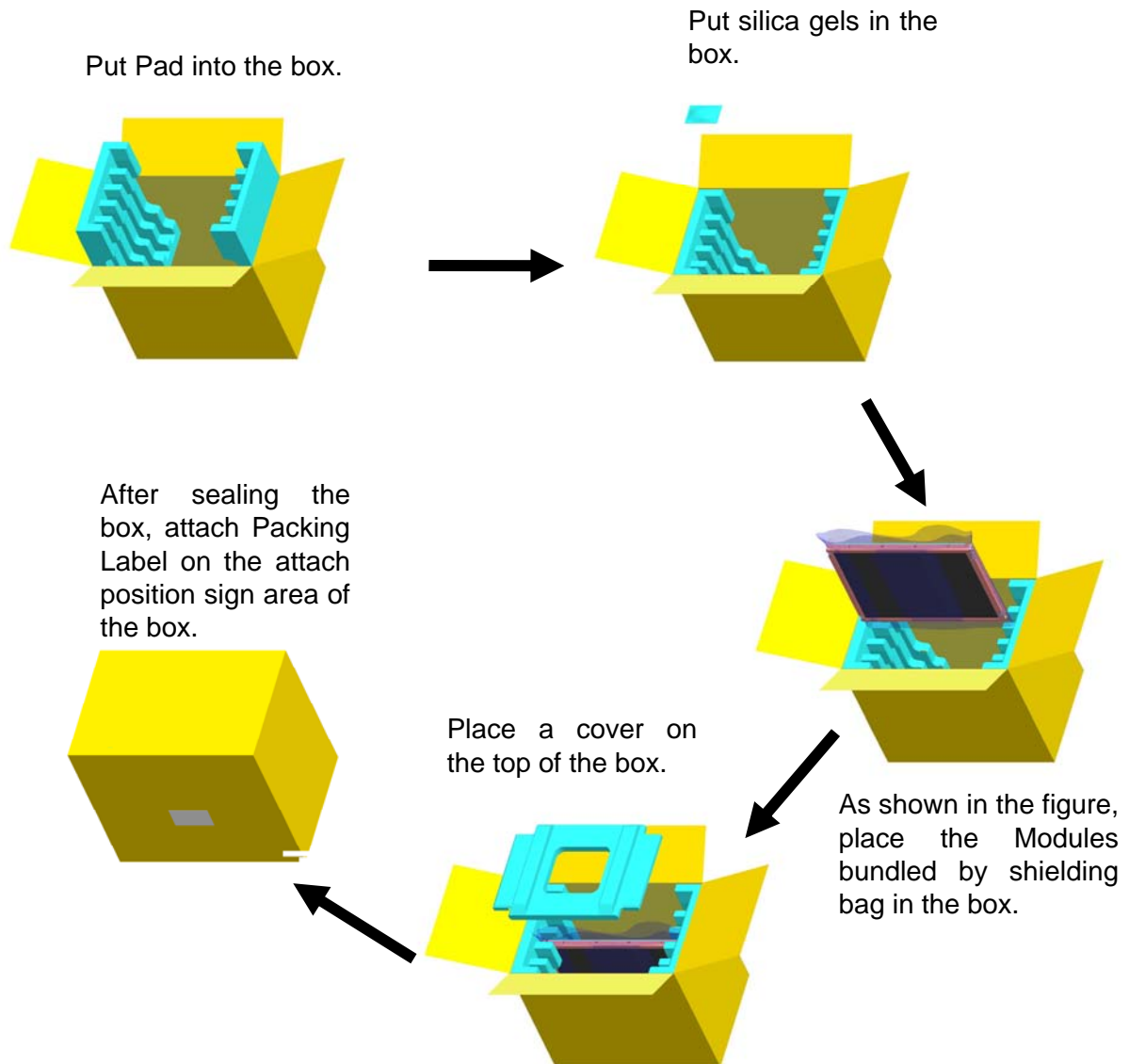

Notes

- Box Dimension: 349 mm (W) X 261 mm (D) X 311 mm (H)
- Package Quantity in one Box: 10pcs



PRODUCT GROUP

REV

ISSUE DATE

TFT LCD PRODUCT

D

2006. 09. 11

14.0 Label

14.1 Packing Label

● Label size : 108 mm (L) X 56 mm (W)

● Contents

Model : HT12X21-351

Q'ty : Module Q'ty in one box

Serial No. : Box Serial No. See next figure for detail description

Date : Packing Date

FG Code : FG Code of Product

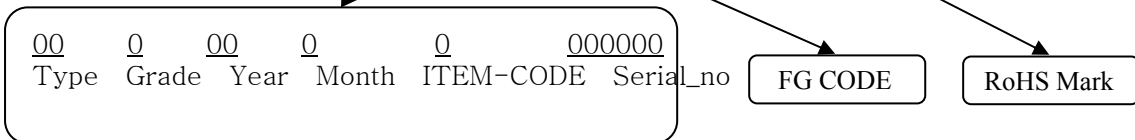
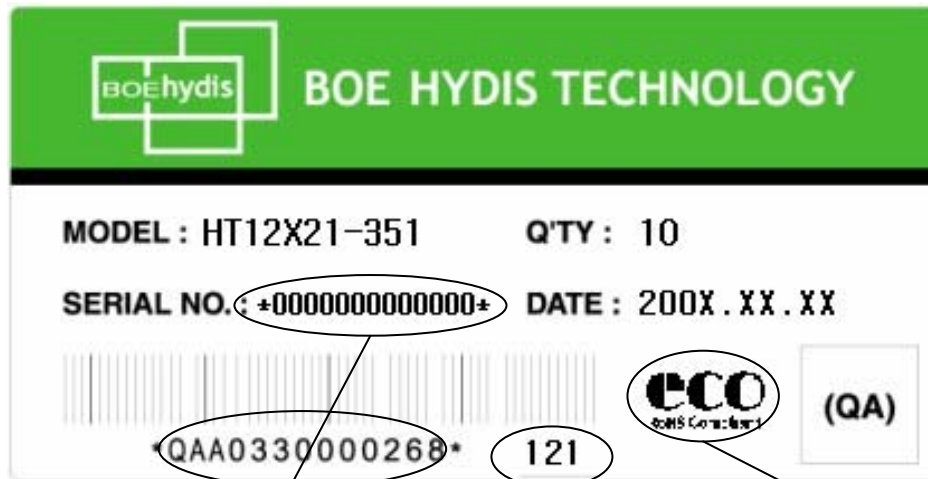

14.2 Mercury disposal & High voltage caution

	<p>HIGH VOLTAGE CAUTION</p> <p>RISK OF ELECTRIC SHOCK. DISCONNECT THE ELECTRIC POWER BEFORE SERVICING</p>	<p>COLD CATHODE FLUORESCENT LAMP IN LCD PANEL CONTAINS A SMALL AMOUNT OF MERCURY. PLEASE FOLLOW LOCAL ORDINANCES OR REGULATIONS FOR DISPOSAL.</p>
--	---	---

SPEC. NUMBER
S864-1216

SPEC TITLE
HT12X21-351 Product specification for Lenovo

PAGE
22 OF 27



PRODUCT GROUP

REV

ISSUE DATE

TFT LCD PRODUCT

D

2006. 09. 11

14.3 Product Label



14.3.1 BOE HYDIS Barcode

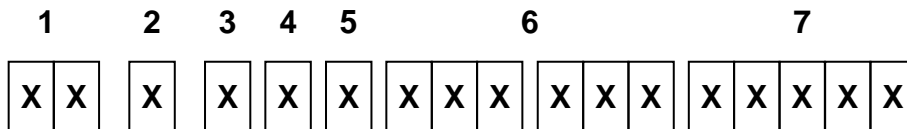

Type Designation

No 1. Control number

No 2. Rank / Grade

No 3. Company (H : BOE HYDIS, O : BOE OT

No 4. Year (4 : 2004, 5 : 2005, ...)

No 5. Month (1, 2, 3, ... , 9, X, Y, Z)

No 6. Product Identification

No 7. Serial Number

14.3.2 Lenovo Barcode

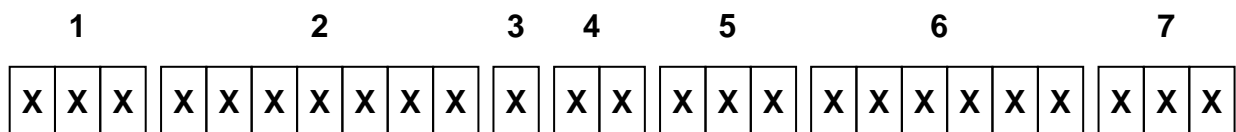

Type Designation

No 1. Barcode Format ID "11S"

No 2. Part Number

No 3. Indicator (Should "Z")

No 4. Yamato Control ID "1Z"

No 5. Code Header

No 6. Serial Number

No.7. Manufacturing Date Code

y : year lower 1 digit

mm : month (01 ~ 12)

SPEC. NUMBER
S864-1216

SPEC TITLE
HT12X21-351 Product specification for Lenovo

PAGE
23 OF 27

15.0 Appendix

Figure 1. Measurement Set up

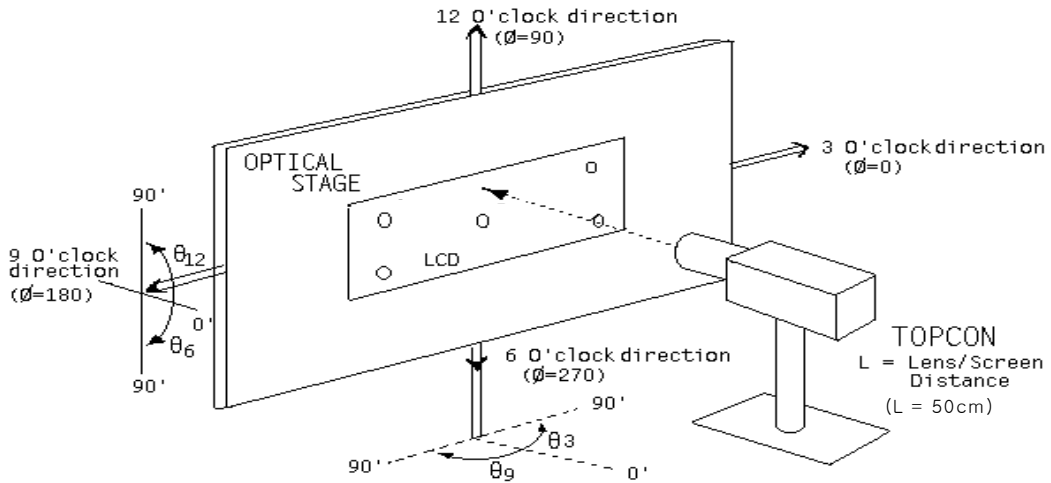

Figure 2. Average Luminance Measurement Locations, 5 points & 13 points Uniformity Measurement Locations

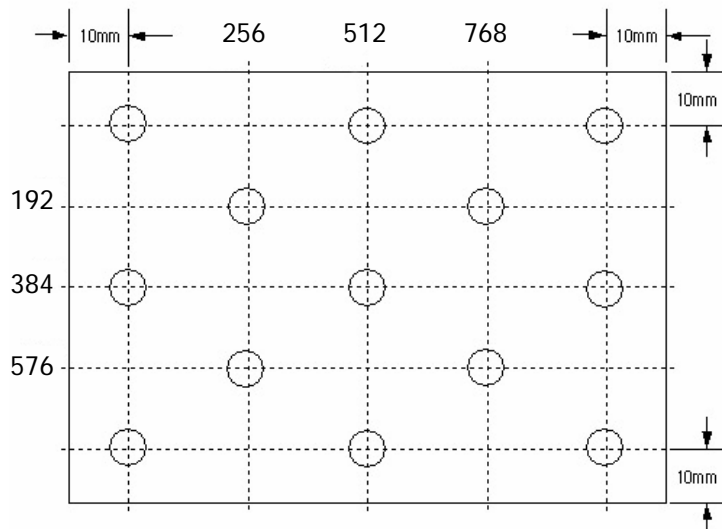

Figure 3. Response Time Testing

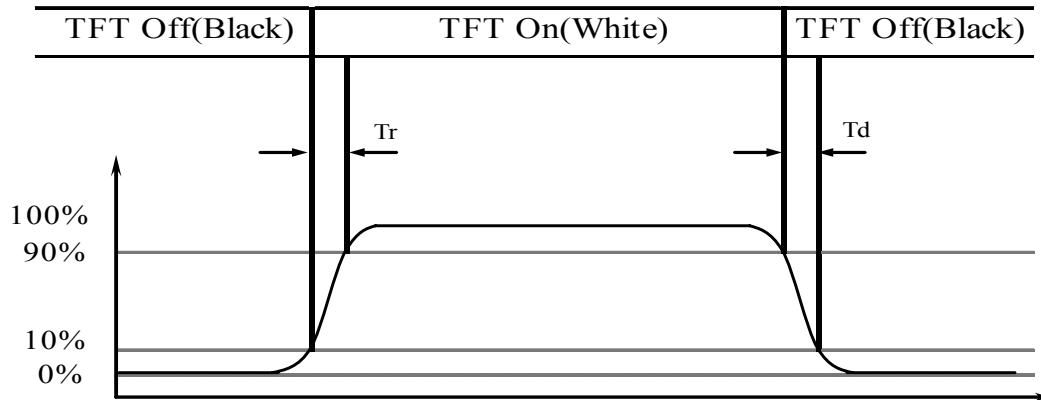
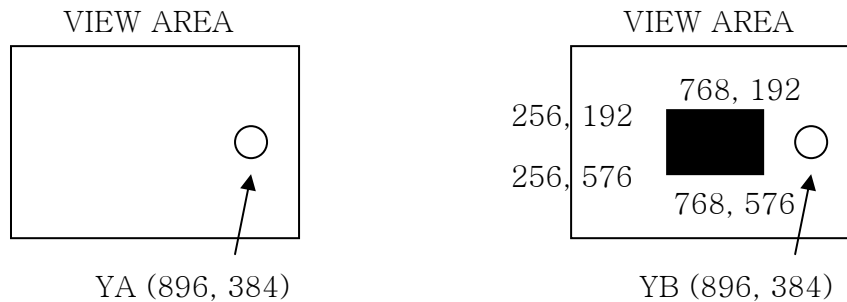

Figure 4. Cross Modulation Test Description



$$\text{Cross Talk} = \frac{YB - YA}{YA} \times 100$$

Where:

 YA = Initial luminance of measured area (cd/m²)

 YB = Subsequent luminance of measured area (cd/m²)

The location measured will be exactly the same in both patterns.

Figure 5. TFT-LCD Module Outline Dimension (Front View)

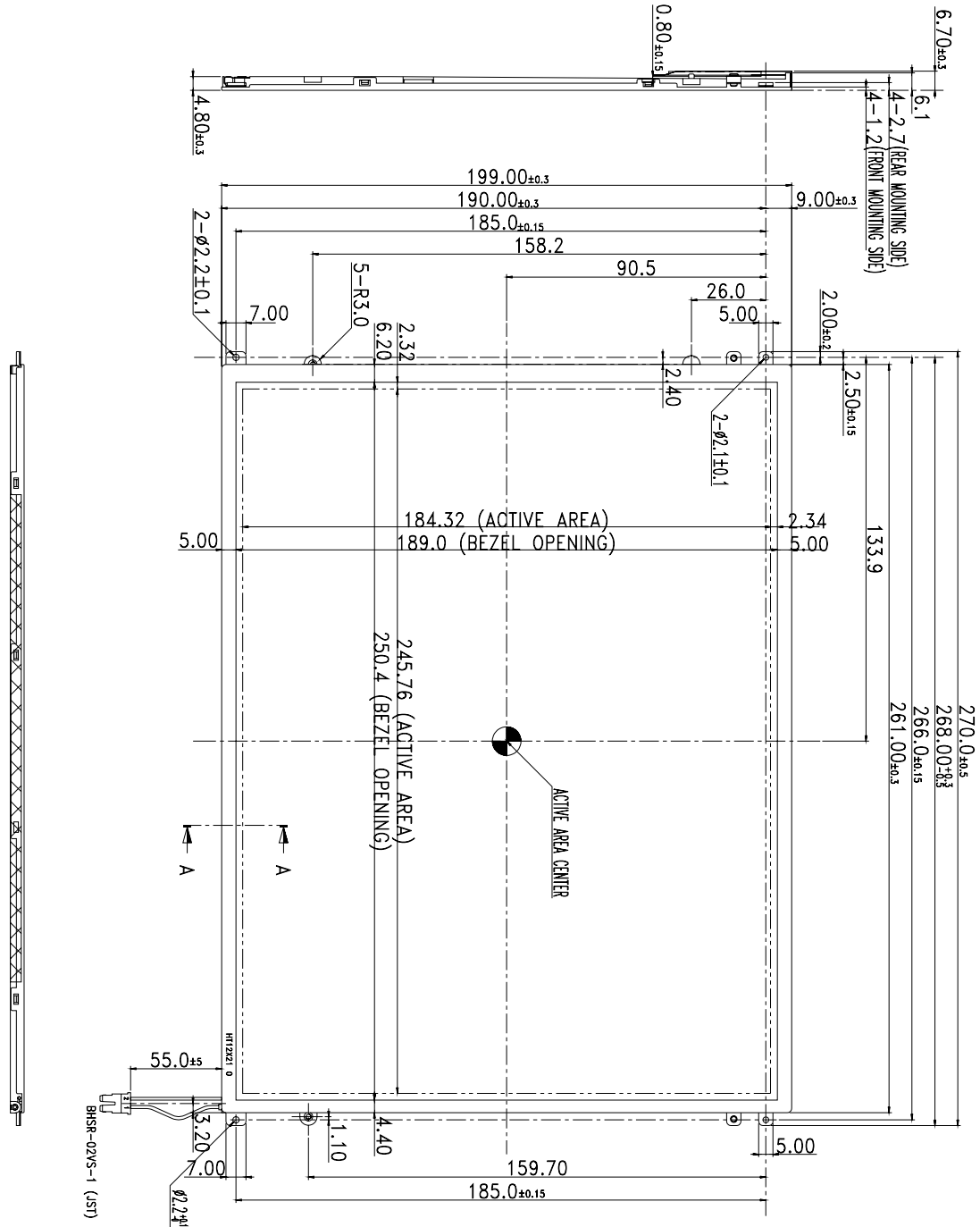

NOTE
 1. UNSPECIFIED TOLERANCE OF DIMENSION IS ± 0.5 .
 2. TORQUE OF INSERT NUT FOR MOUNTING DIGITIZER :
 MAX. 3.0 kgf.

SPEC. NUMBER
 S864-1216

SPEC TITLE
 HT12X21-351 Product specification for Lenovo

PAGE
 26 OF 27

Figure 6. TFT-LCD Module Outline Dimensions (Rear View)

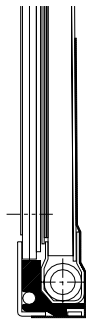
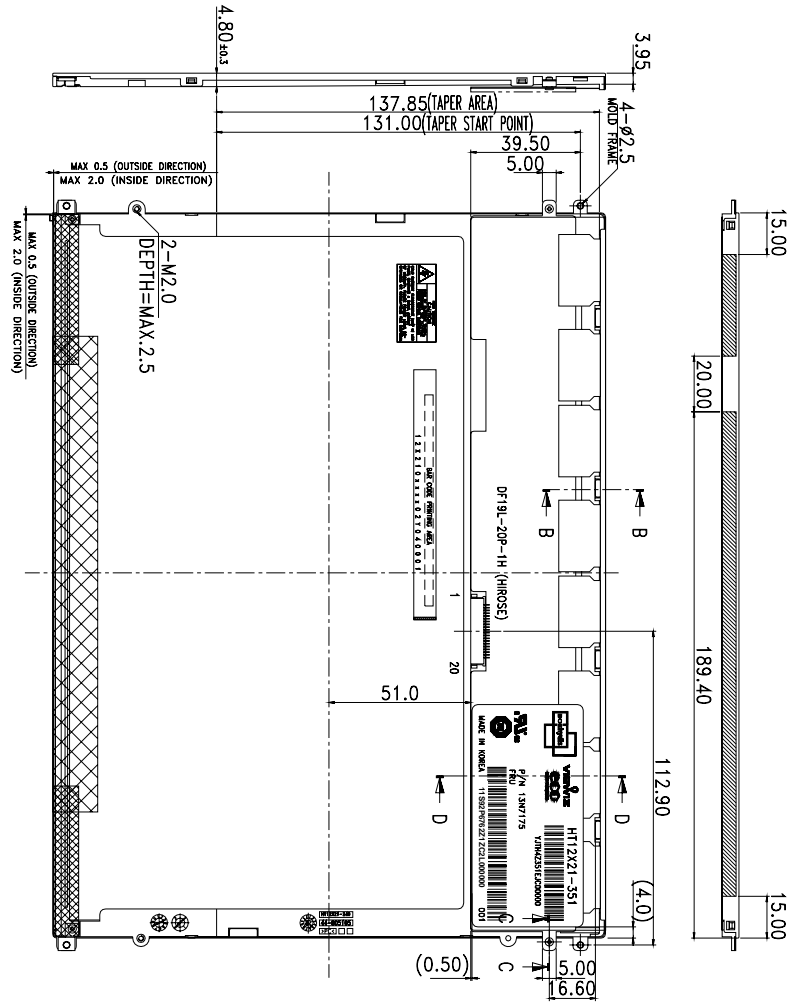

SECTION A-A (S:5:1)



SECTION B-B (S:5:1)

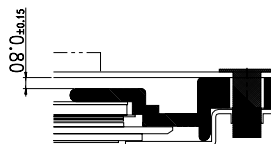

SECTION C-C (S:5:1)

SPEC. NUMBER
S864-1216

SPEC TITLE
HT12X21-351 Product specification for Lenovo

PAGE
27 OF 27