



Document Title	HSD101PFW4-B Product Information for Solomon	Page No.	1/28
Document No.		Revision	1.5

TO : Solomon

Date : Mar., 28, 2012

HannStar Product Information

Model: **HSD101PFW4**
-B00

Note:

1. Please contact HannStar Display Corp. before designing your product based on this module specification.
2. The information contained herein is presented merely to indicate the characteristics and performance of our products. No responsibility is assumed by HannStar for any intellectual property claims or other problems that may result from application based on the module described herein.



Document Title	HSD101PFW4-B Product Information for Solomon	Page No.	2/28
Document No.		Revision	1.5

Record of Revisions

Rev.	Date	Sub-Model	Description of change
1.0	Nov., 24, 2011	B00	Product information was first released.
1.1	Nov., 30, 2011	B00	P6 Update color chromaticity.
1.2	Jan., 19, 2012	B00	P12 Update pin 2&3&20 signal & definition. P19 Update 6.5 power on/off sequence drawing. P20 Update 6.7.1 absolute maximum ratings
1.3	Feb., 1, 2012	B00	P24 Update back view drawing.
1.4	Mar., 2, 2012	B00	P5 Update mechanical information.
1.5	Mar., 28, 2012	B00	P18 Update interface timing. P19 Update power on/off sequence. P20 Add light bar configuration drawing P23&24 Update outline drawing.



Document Title	HSD101PFW4-B Product Information for Solomon	Page No.	3/28
Document No.		Revision	1.5

Contents

1.0	General description	p.4
2.0	Absolute maximum ratings.....	p.5
3.0	Optical characteristics.....	p.6
4.0	Block diagram	p.10
5.0	Interface pin connection	p.12
6.0	Electrical characteristics	p.15
7.0	Reliability test items	p.22
8.0	Outline dimension	p.23
9.0	Lot mark	p.25
10.0	Package specification	p.26
11.0	General precaution	p.27

Document Title	HSD101PFW4-B Product Information for Solomon	Page No.	4/28
Document No.		Revision	1.5

1.0 GENERAL DESCRIPTION

1.1 Introduction

HannStar Display model HSD101PFW4-B is a color active matrix thin film transistor (TFT) liquid crystal display (LCD) that uses amorphous silicon TFT as a switching device. This model is composed of a TFT LCD panel, a driving circuit and a back light system. This TFT LCD has a 10.1 (16:9) inch diagonally measured active display area with WSVGA (1024 horizontal by 600 vertical pixel) resolution.

1.2 Features

- 10.1 (16:9 diagonal) inch configuration
- One channel LVDS interface
- 262K color by 6 bit R.G.B signal input
- RoHS Compliance
- Halogen Free

1.3 Applications

- Mobile NB
- Digital Photo frame
- Display terminal for AV application

1.4 General information

Item	Specification	Unit
Outline Dimension	248.8x 146.5 (typ) w/ Bracket & PCB	mm
Display area	222.72(H) x 125.28(V)	mm
Number of Pixel	1024 RGB (H) x 600(V)	pixels
Pixel pitch	0.2175(H) x 0.2088(V)	mm
Pixel arrangement	RGB Vertical stripe	
Display mode	Normally white	
NTSC	45	%
Surface treatment	Antiglare (3H)	
Weight	170 (Max.)	g
Back-light	White LED	
Power Consumption	Logic 0.7 (Max) BL 1.85 (Max) (L0 pattern, V _{DD} =3.3V)	W

Document Title	HSD101PFW4-B Product Information for Solomon	Page No.	5/28
Document No.		Revision	1.5

1.5 Mechanical Information

Item		Min.	Typ.	Max.	Unit	Remark
Module Size	Horizontal (H)	244.5	245.0	245.5	mm	W/ bracket & PCB
	Vertical (V)	146	146.5	147	mm	
	Depth (D)	—	3.3	3.6	mm	
Weight		—	160	170	g	

2.0 ABSOLUTE MAXIMUM RATINGS

2.1 Electrical Absolute Rating

2.1.1 TFT LCD Module

Item	Symbol	Min.	Max.	Unit	Note
LED Power Supply voltage	V_{LED}	-0.3	6.0	V	GND=0
Logic Supply voltage	V_{DD}	-0.3	6.0	V	

2.2 Environment Absolute Rating

Item	Symbol	Min.	Max.	Unit	Note
Operating Temperature	T_{opa}	0	50	°C	
Storage Temperature	T_{stg}	-20	60	°C	

Document Title	HSD101PFW4-B Product Information for Solomon	Page No.	6/28
Document No.		Revision	1.5

3.0 OPTICAL CHARACTERISTICS

3.1 Optical specification

Item		Symbol	Condition	Min.	Typ.	Max.	Unit	Note
Contrast		CR	$\theta=0$ Normal viewing angle	400	500	—		(1)(2)(4)
Response time		Tr		—	4	6	msec	(1)(3)
		Tf		—	12	19		
White luminance (5 point)		Y_L			170	200	—	cd/m ²
Color chromaticity (CIE1931)	Red	R_x	$\theta=0$ Normal viewing angle	-0.03	0.581	+0.03		
		R_y			0.351			
	Green	G_x			0.327			
		G_y			0.576			
	Blue	B_x			0.162			
		B_y			0.106			
	White	W_x			0.313			
		W_y			0.329			
Viewing angle	Hor.	θ_L	CR>10	40	45	—		(1)(4)
		θ_R		40	45	—		
	Ver.	θ_U		10	15	—		
		θ_D		30	35	—		
Brightness uniformity		B_{UNI}	$\theta=0$ (5point)	—	—	1.25		(5)
Brightness Uniformity		B_{UNI}	$\theta=0$ (13 points)	—	—	1.5		(6)

3.2 Measuring Condition

- Measuring surrounding : dark room
- Ambient temperature : 25±3°C
- 15min. warm-up time.

Document Title	HSD101PFW4-B Product Information for Solomon	Page No.	7/28
Document No.		Revision	1.5

3.3 Measuring Equipment

- FPM520 of Westar Display technologies, INC., which utilized SR-3 for Chromaticity and BM-5A for other optical characteristics.

- Measuring spot size : 20 ~ 21 mm

Note (1) Definition of Viewing Angle:

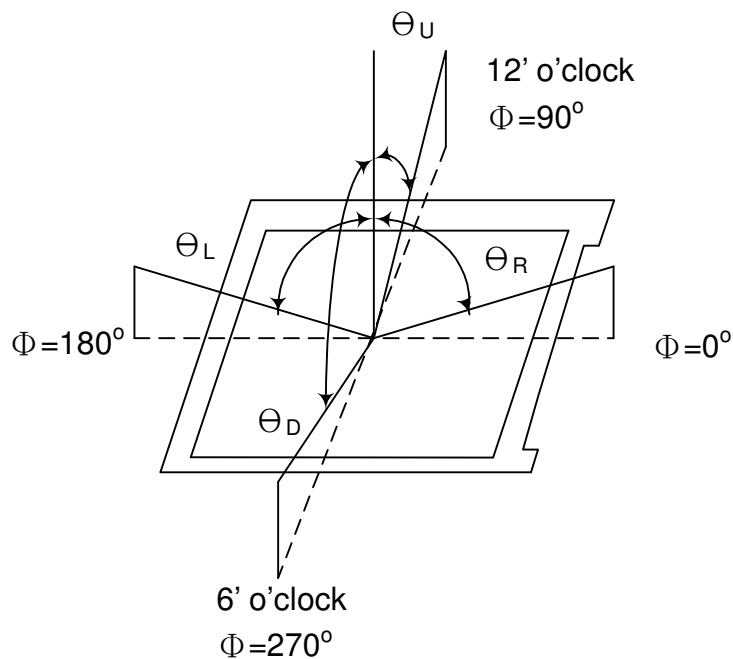

Note (2) Definition of Contrast Ratio (CR) :
measured at the center point of panel

$$CR = \frac{\text{Luminance with all pixels white}}{\text{Luminance with all pixels black}}$$

Document Title	HSD101PFW4-B Product Information for Solomon	Page No.	8/28
Document No.		Revision	1.5

Note (3) Definition of Response Time : Sum of T_R and T_F

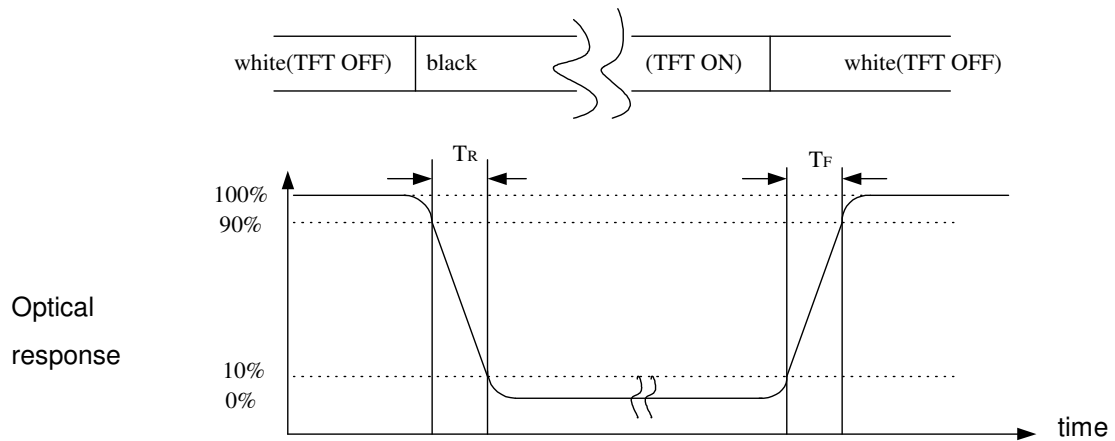

Note (4) Definition of optical measurement setup

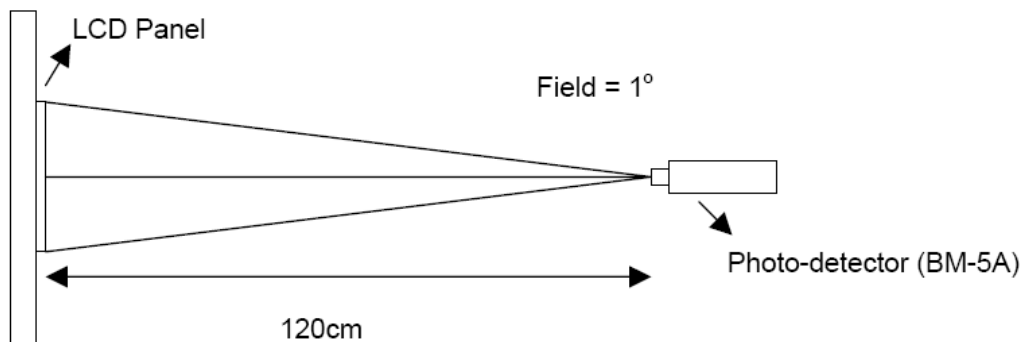

Document Title	HSD101PFW4-B Product Information for Solomon	Page No.	9/28
Document No.		Revision	1.5

Note (5) Definition of Average Luminance Uniformity of White (5 Point)

$$\text{Average Luminance Uniformity} = \frac{Y_1+Y_2+Y_3+Y_4+Y_5}{5}$$

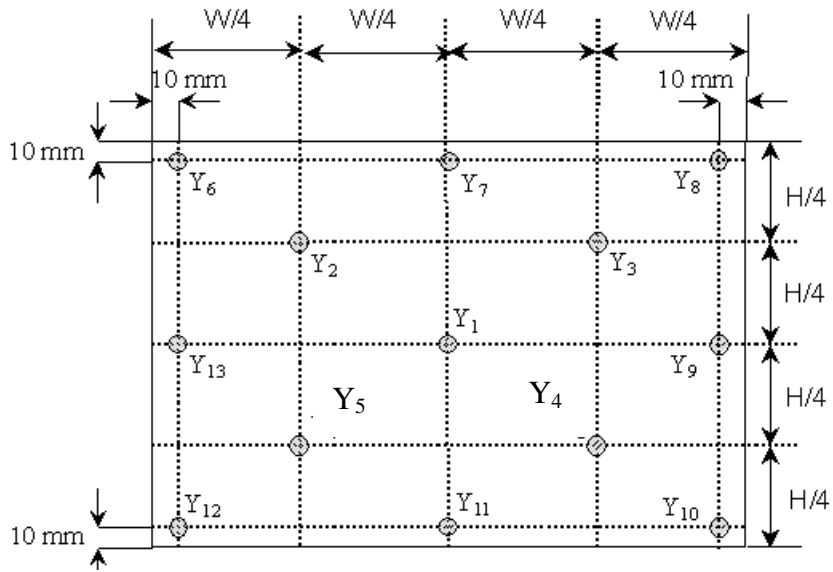

Note (6) Definition of brightness uniformity

$$\text{Luminance uniformity} = \frac{(\text{Max Luminance of 5 points})}{(\text{Min Luminance of 5 points})}$$

$$\text{Luminance uniformity} = \frac{(\text{Max Luminance of 13 points})}{(\text{Min Luminance of 13 points})}$$

Document Title	HSD101PFW4-B Product Information for Solomon	Page No.	10/28
Document No.		Revision	1.5

4.0 BLOCK DIAGRAM

4.1 TFT LCD Module:

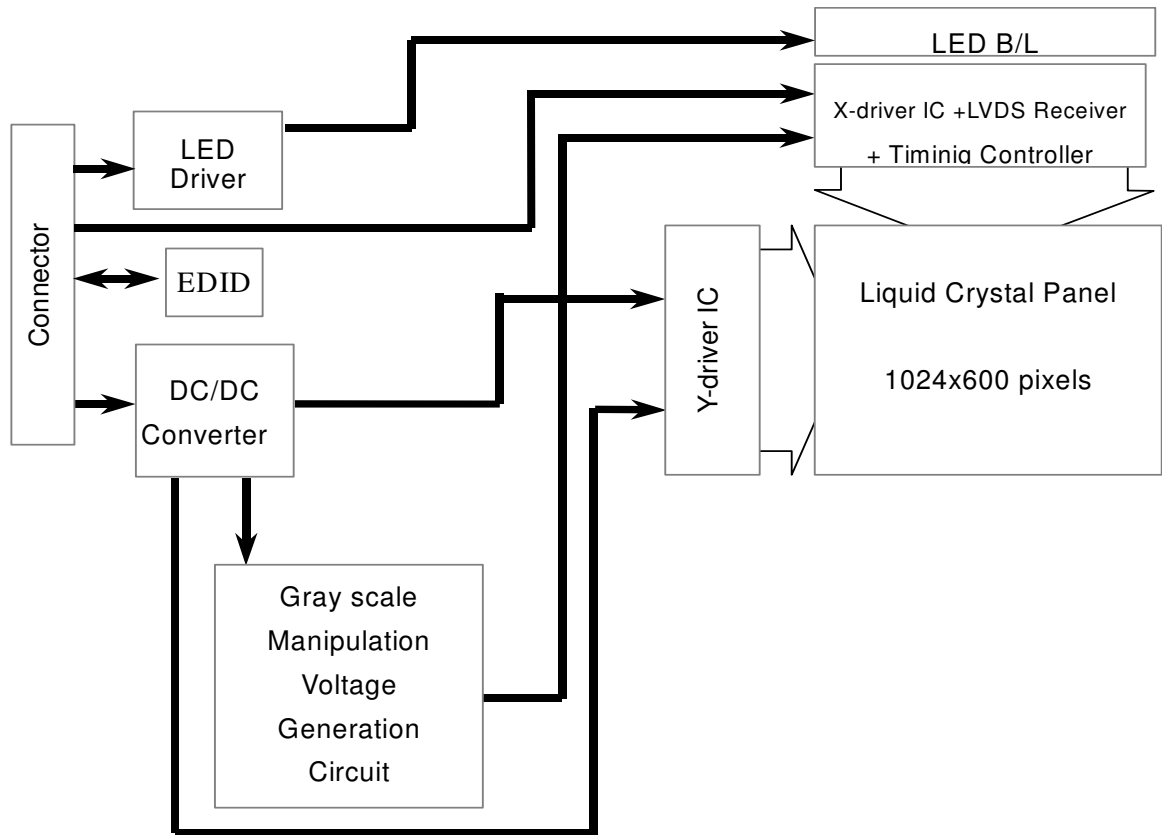

Pixel Format

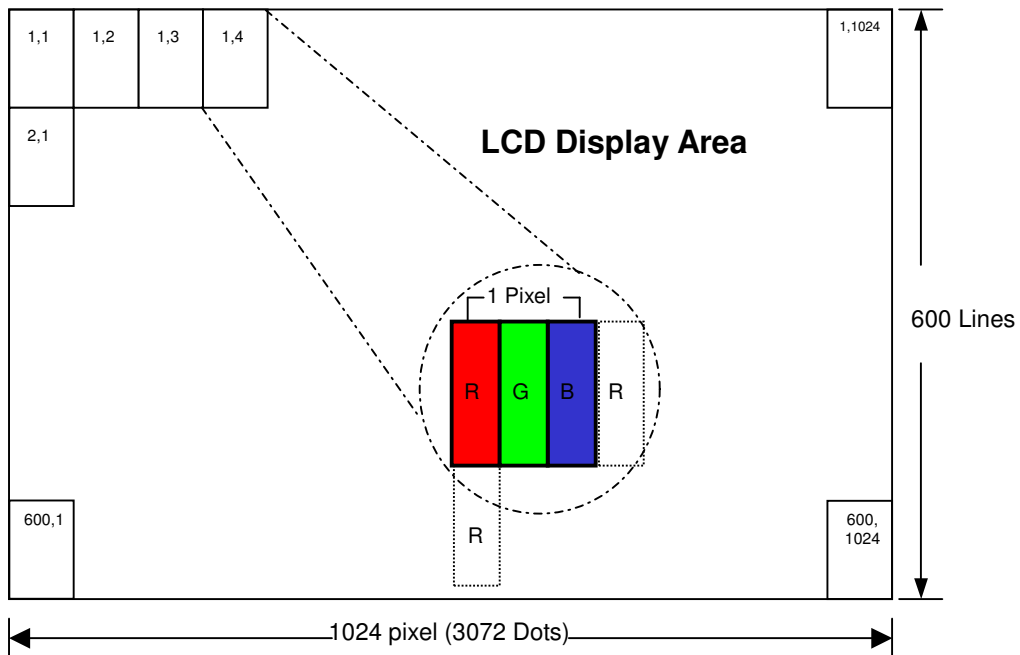

Document Title	HSD101PFW4-B Product Information for Solomon	Page No.	11/28
Document No.		Revision	1.5

4.2 Relationship Between Displayed Color and Input

Display	MSB						LSB						MSB						LSB						Gray scale level
	R5	R4	R3	R2	R1	R0	G5	G4	G3	G2	G1	G0	B5	B4	B3	B2	B1	B0							
Basic color	Black	L	L	L	L	L	L	L	L	L	L	L	L	L	L	L	L	L	L	-					
	Blue	L	L	L	L	L	L	L	L	L	L	L	L	H	H	H	H	H	H	-					
	Green	L	L	L	L	L	L	H	H	H	H	H	H	L	L	L	L	L	L	-					
	Light Blue	L	L	L	L	L	L	H	H	H	H	H	H	H	H	H	H	H	H	-					
	Red	H	H	H	H	H	H	L	L	L	L	L	L	L	L	L	L	L	L	-					
	Purple	H	H	H	H	H	H	L	L	L	L	L	L	H	H	H	H	H	H	-					
	Yellow	H	H	H	H	H	H	H	H	H	H	H	H	L	L	L	L	L	L	-					
	White	H	H	H	H	H	H	H	H	H	H	H	H	H	H	H	H	H	H	-					
Gray scale of Red	Black	L	L	L	L	L	L	L	L	L	L	L	L	L	L	L	L	L	L	L0					
	Dark ↑ ↓ Light	L	L	L	L	L	H	L	L	L	L	L	L	L	L	L	L	L	L	L1					
		L	L	L	L	H	L	L	L	L	L	L	L	L	L	L	L	L	L	L2					
		⋮	⋮	⋮	⋮	⋮	⋮	⋮	⋮	⋮	⋮	⋮	⋮	⋮	⋮	⋮	⋮	⋮	⋮	⋮	L3...L60				
		H	H	H	H	L	H	L	L	L	L	L	L	L	L	L	L	L	L	L61					
	H	H	H	H	H	L	L	L	L	L	L	L	L	L	L	L	L	L	L62						
	Red	H	H	H	H	H	H	L	L	L	L	L	L	L	L	L	L	L	L	Red L63					
	Gray scale of Green	Black	L	L	L	L	L	L	L	L	L	L	L	L	L	L	L	L	L	L	L0				
Dark ↑ ↓ Light		L	L	L	L	L	L	L	L	L	L	L	H	L	L	L	L	L	L	L1					
		L	L	L	L	L	L	L	L	L	L	H	L	L	L	L	L	L	L	L2					
		⋮	⋮	⋮	⋮	⋮	⋮	⋮	⋮	⋮	⋮	⋮	⋮	⋮	⋮	⋮	⋮	⋮	⋮	⋮	L3...L60				
		L	L	L	L	L	L	H	H	H	H	L	H	L	L	L	L	L	L	L61					
L		L	L	L	L	L	H	H	H	H	H	L	L	L	L	L	L	L	L62						
Green		L	L	L	L	L	L	H	H	H	H	H	H	L	L	L	L	L	Green L63						
Gray scale of Blue		Black	L	L	L	L	L	L	L	L	L	L	L	L	L	L	L	L	L	L	L0				
	Dark ↑ ↓ Light	L	L	L	L	L	L	L	L	L	L	L	L	L	L	L	L	L	H	L1					
		L	L	L	L	L	L	L	L	L	L	L	L	L	L	L	L	H	L	L2					
		⋮	⋮	⋮	⋮	⋮	⋮	⋮	⋮	⋮	⋮	⋮	⋮	⋮	⋮	⋮	⋮	⋮	⋮	⋮	L3...L60				
		L	L	L	L	L	L	L	L	L	L	L	L	H	H	H	H	L	H	L61					
	L	L	L	L	L	L	L	L	L	L	L	L	H	H	H	H	H	L	L62						
	Blue	L	L	L	L	L	L	L	L	L	L	L	L	H	H	H	H	H	Blue L63						
	Gray scale of White & Black	Black	L	L	L	L	L	L	L	L	L	L	L	L	L	L	L	L	L	L	L0				
Dark ↑ ↓ Light		L	L	L	L	L	H	L	L	L	L	L	H	L	L	L	L	L	H	L1					
		L	L	L	L	H	L	L	L	L	L	H	L	L	L	L	L	H	L	L2					
		⋮	⋮	⋮	⋮	⋮	⋮	⋮	⋮	⋮	⋮	⋮	⋮	⋮	⋮	⋮	⋮	⋮	⋮	⋮	L3...L60				
		H	H	H	H	L	H	H	H	H	H	L	H	H	H	H	H	L	H	L61					
H		H	H	H	H	L	H	H	H	H	H	L	H	H	H	H	H	L	L62						
White	H	H	H	H	H	H	H	H	H	H	H	H	H	H	H	H	H	White L63							

Document Title	HSD101PFW4-B Product Information for Solomon	Page No.	12/28
Document No.		Revision	1.5

5.0 INTERFACE PIN CONNECTION

4.1 TFT LCD Module : CN1 (Input signal): STM MSAK24025P40B or equivalent

Pin	Signal	Description
1	GND	Ground
2	VDD	PowerSupply,3.3V(typical)
3	VDD	PowerSupply,3.3V(typical)
4	DVDD	DDC3.3V power
5	NC	NC
6	SCL	DDC Clock
7	SDA	DDC Data
8	Rin0-	- LVDSdifferential data input
9	Rin0+	+ LVDSdifferential data input
10	GND	Ground
11	Rin1-	- LVDSdifferential data input
12	Rin1+	+ LVDSdifferential data input
13	GND	Ground
14	Rin2-	- LVDSdifferential data input
15	Rin2+	+ LVDSdifferential data input
16	GND	Ground
17	ClKIN-	- LVDSdifferential data input
18	ClKIN+	+ LVDSdifferential data input
19	GND	Ground
20	EN	Normal pull high (+3.3V) (Note)
21	NC	No Connection
22	GND	Ground
23	NC	No Connection
24	NC	No Connection
25	GND	Ground
26	NC	No Connection
27	NC	No Connection
28	GND	Ground
29	NC	No Connection
30	NC	No Connection
31	VLED_GND	LED Ground
32	VLED_GND	LED Ground
33	VLED_GND	LED Ground
34	NC	No Connection
35	PWM	System PWM Signal Input
36	VLED_EN	LED enable pin(+3.3V input)/VLED on/off

Document Title	HSD101PFW4-B Product Information for Solomon	Page No.	13/28
Document No.		Revision	1.5

37	NC	No Connection
38	VLED	LED Power Supply5-21V
39	VLED	LED Power Supply5-21V
40	VLED	LED Power Supply5-21V

Note : The brightness of LCD panel could be changed by adjusting PWM
 The pin 20 (EN) must be pulled high that ensures power supply 3.3V normally work.

[Note]

(1) ADJ can adjust brightness to control Pin. Pulse duty the bigger the brighter.

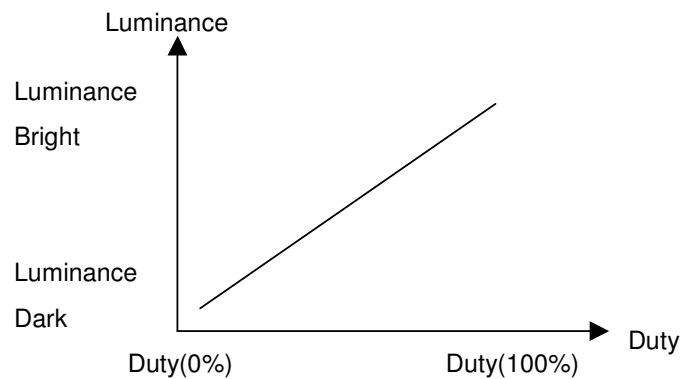

(2) ADJ Signal=0~3.3V · Operation Conditions :

Parameter	Symbol	Conditions	Min	Typ	Max	Unit
ADJ Logic-High Level	V _{ADJH}		1.8	3.3	3.6	V
ADJ Logic-Low Level	V _{ADJL}		0	0	0.4	V
PWM Frequency	FPWM		225	--	275	Hz
PWM Duty Cycle	D		10	--	100	%

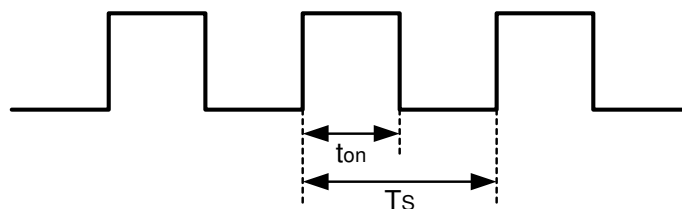

$$D = t_{on} / T_s \times 100\%$$

$$F_{ADJ} = 1 / T_s$$

Document Title	HSD101PFW4-B Product Information for Solomon	Page No.	14/28
Document No.		Revision	1.5

(3) VLED_EN & VDDA_EN & CABC_EN , Operation Conditions :

Parameter	Symbol	Min	Typ	Max	Units	Remark
LED enable pin (control LED driver circuit on/off)	LED_EN (H)	3.0	3.3	3.6	Volt	LED on
	LED_EN (L)	--	0	0.2		LED off
VDD on/off signal (control Panel VDD power source on/off)	VDDA_EN (H)	3.0	3.3	3.6	Volt	VDD on
	VDDA_EN (L)	--	0	0.2		VDD off

Document Title	HSD101PFW4-B Product Information for Solomon	Page No.	15/28
Document No.		Revision	1.5

6.0 ELECTRICAL CHARACTERISTICS

6.1 TFT LCD Module

Item	Symbol	Min.	Typ.	Max.	Unit	Note
Supply Voltage	V _{DD}	3.0	3.3	3.6	V	Note (1)
Current of power supply	I _{DD}	-	0.19	-	A	V _{DD} =3.3V Ta=25°C fv=60Hz Note (2)(3)
Inrush current	I _{RUSH}	-	-	1.50	A	Note (4)

Note : (1) V_{DD}-dip condition :

When VDD operating within $2.7V \leq VDD < 3.0V$, $t_d \leq 10ms$, the display may momentarily become abnormal .

VDD<2.7V, VDD dip condition should also follow the Power On/Off conditions for supply voltage.

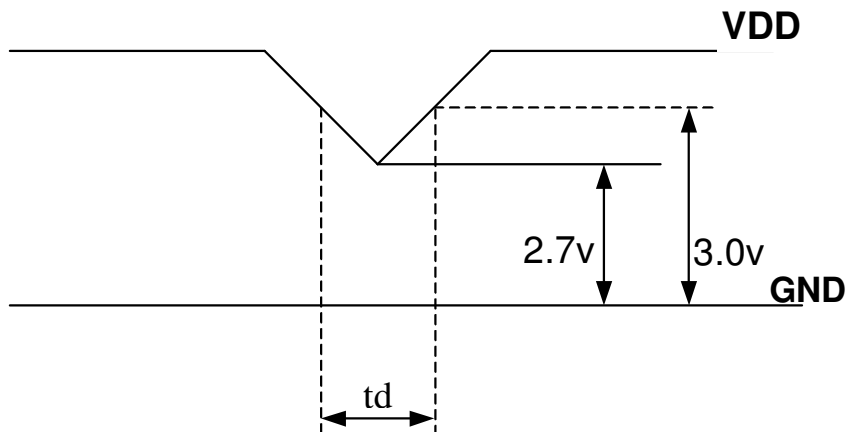

(2) Maximum Measurement Condition: Black Pattern

(3) Typical Measurement Condition: Mosaic Pattern

Document Title	HSD101PFW4-B Product Information for Solomon	Page No.	16/28
Document No.		Revision	1.5

(4) Power on Inrush current test circuit

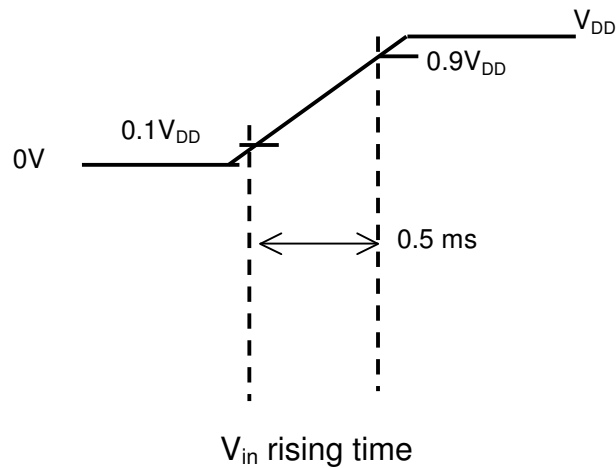
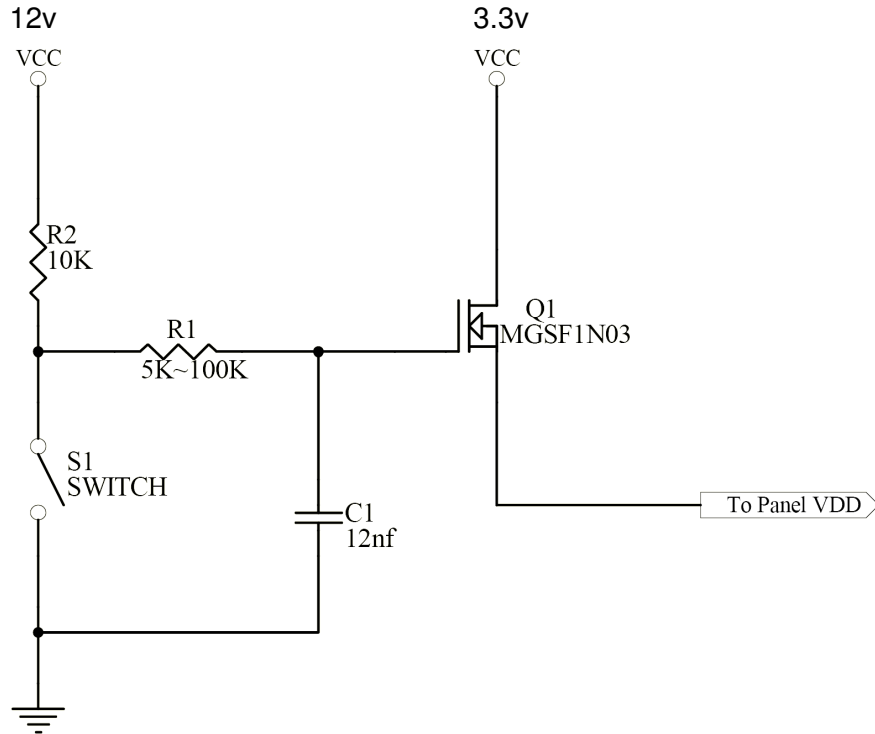

Document Title	HSD101PFW4-B Product Information for Solomon	Page No.	17/28
Document No.		Revision	1.5

6.2 Switching Characteristics for LVDS Receiver

Item	Symbol	Min.	Typ.	Max.	Unit	Conditions
Differential Input High Threshold	V_{th}	—	—	100	mV	$V_{CM}=1.2V$
Differential Input Low Threshold	V_{tl}	-100	—	—	mV	
Input Current	I_{IN}	-10	—	+10	μA	
Differential input Voltage	$ V_{ID} $	0.2	—	0.6	V	
Common Mode Voltage Offset	V_{CM}	0.7	1.2	1.6	V	

6.3 Bit Mapping & Interface Definition

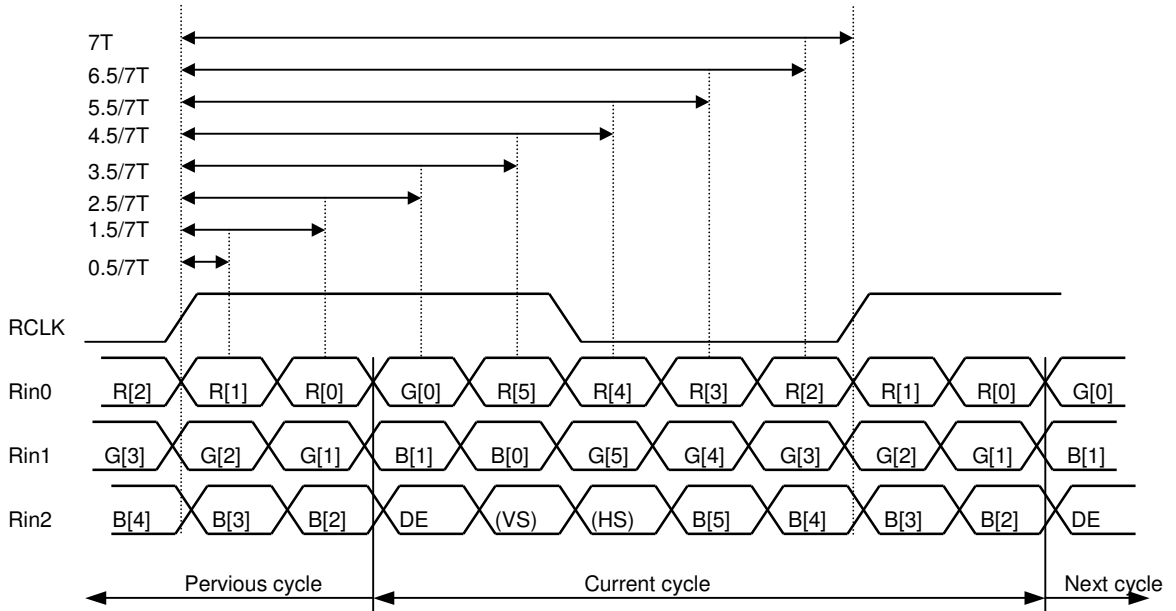

LVDS Receiver Input Timing Definition
for 6bits LVDS input

Document Title	HSD101PFW4-B Product Information for Solomon	Page No.	18/28
Document No.		Revision	1.5

6.4 Interface Timing (DE mode)

Item	Symbol	Min.	Typ.	Max.	Unit
Frame Rate	--	55	60	65	Hz
Frame Period	t1	612	695	700	line
Vertical Display Time	t2	600	600	600	line
Vertical Blanking Time	t3	12	96	100	line
1 Line Scanning Time	t4	1114	1381	1400	clock
Horizontal Display Time	t5	1024	1024	1024	clock
Horizontal Blanking Time	t6	90	357	376	clock
Clock Rate	t7	40.8	57.6	63.7	MHz

Timing Diagram of Interface Signal (DE mode)

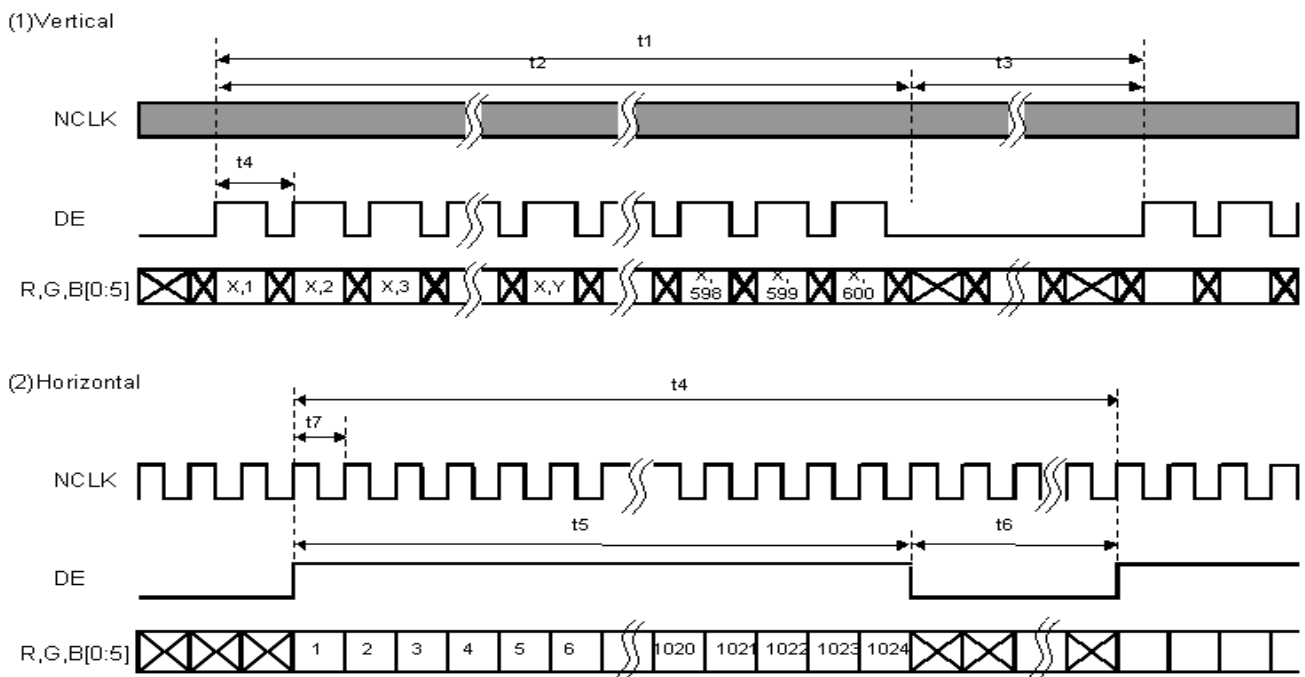

Document Title	HSD101PFW4-B Product Information for Solomon	Page No.	19/28
Document No.		Revision	1.5

6.5 Power On / Off Sequence

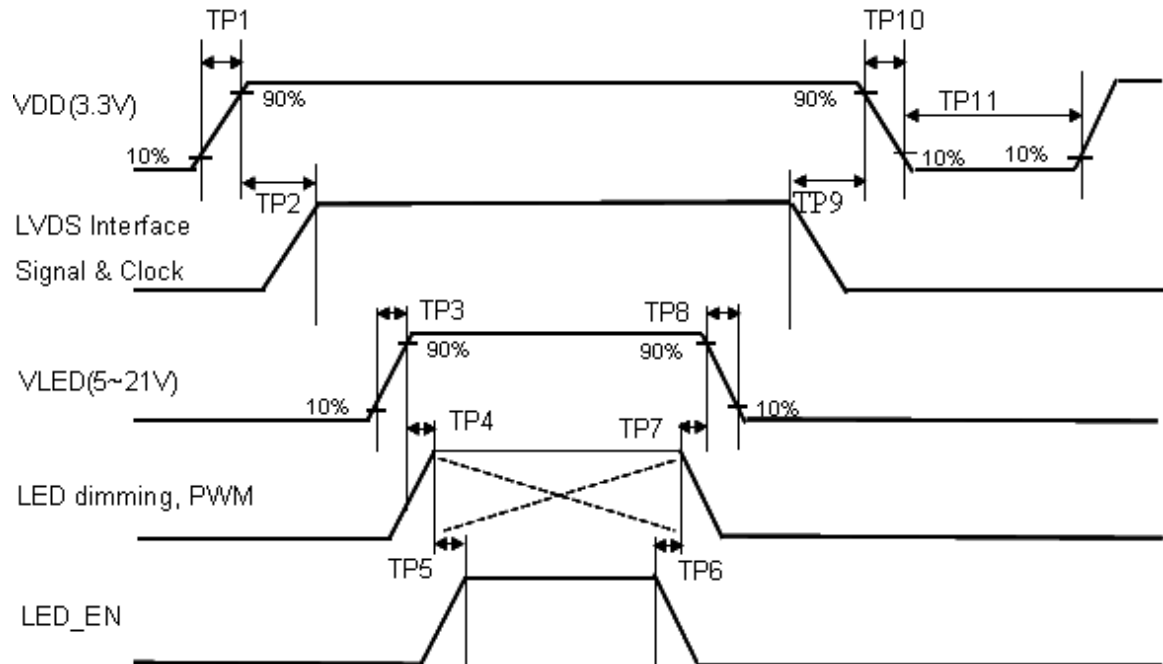

Item	Min.	Typ.	Max.	Unit	Remark
TP1	0.5	--	10	msec	
TP2	0	--	50	msec	
TP3	0.5	--	10	msec	
TP4	10	--	--	msec	
TP5	10	--	--	msec	
TP6	0	--	--	msec	
TP7	10	--	--	msec	
TP8	0	--	10	msec	
TP9	0	--	50	msec	
TP10	1	--	10	msec	
TP11	1000	--	--	msec	

Document Title	HSD101PFW4-B Product Information for Solomon	Page No.	20/28
Document No.		Revision	1.5

- Note: (1) The supply voltage of the external system for the module input should be the same as the definition of V_{DD} .
- (2) Apply the lamp voltage within the LCD operation range. When the back-light turns on before the LCD operation or the LCD turns off before the back-light turns off, the display may momentarily become white.
- (3) In case of V_{DD} = off level, please keep the level of input signal on the low or keep a high impedance.
- (4) TP4 should be measured after the module has been fully discharged between power off and on period.
- (5) Interface signal shall not be kept at high impedance when the power is on.

6.6 Backlight Unit

Parameter	Symbol	Min	Typ	Max	Units	Condition
LED Current	I_F	--	19.5	--	mA	$T_a=25^{\circ}C$
LED Voltage	V_F	3.0	3.2	3.4	Volt	$T_a=25^{\circ}C$
LED Power consumption	P_{LED}	--	1.50	1.59	Watt	$T_a=25^{\circ}C$ Note (1)
LED Life-Time	N/A	10,000	--	--	Hour	$T_a=25^{\circ}C$ $I_F=20mA$ Note (2)

Note (1): Calculator value for reference $P=I_F \times V_F \times N$ (LED Qty')

Note (2): The LED lifetime defines as the estimated time to 50% degradation of final luminous.

Note (3): LED light bar configuration is shown as below.

Light Bar configuration drawing

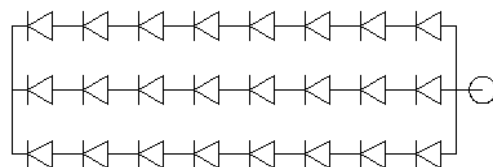

Document Title	HSD101PFW4-B Product Information for Solomon	Page No.	21/28
Document No.		Revision	1.5

6.7 LED Driver

6.7.1 Absolute Maximum Ratings

Item	Symbol	Min.	Max.	Unit	Note
LED Power Supply voltage	V_{LED}	-0.3	27	Volt	LED driver IC original value
LED_EN, PWM pin Voltage	V_{EN}, V_{PWM}	-0.3	27	Volt	

6.7.2 DC Electrical Characteristics

Parameter	Symbol	Min	Typ	Max	Units	Remark
LED Power Supply Voltage	V_{LED}	5	--	21	Volt	
PWM High Threshold	V_{PWMH}	3.0	--	--	Volt	
PWM Low Threshold	V_{PWML}	--	--	0.2	Volt	

Document Title	HSD101PFW4-B Product Information for Solomon	Page No.	22/28
Document No.		Revision	1.5

7.0 Reliability test items

No.	Item	Conditions	Remark
1	High Temperature Storage	Ta=+60°C, 240hrs	
2	Low Temperature Storage	Ta=-20°C, 240hrs	
3	High Temperature Operation	Ta=+50°C, 300hrs	
4	Low Temperature Operation	Ta=0°C, 300hrs	
5	Thermal Cycling Test (non operation)	-20°C(30min)→+60°C(30min),100 cycles	
6	Vibration	Sine Wave 1.5G, 5~500Hz, XYZ 30min/each direction	
7	Shock	Half-Sine, 200G, 2ms, ±XYZ, 1time	

Storage / Operating temperature

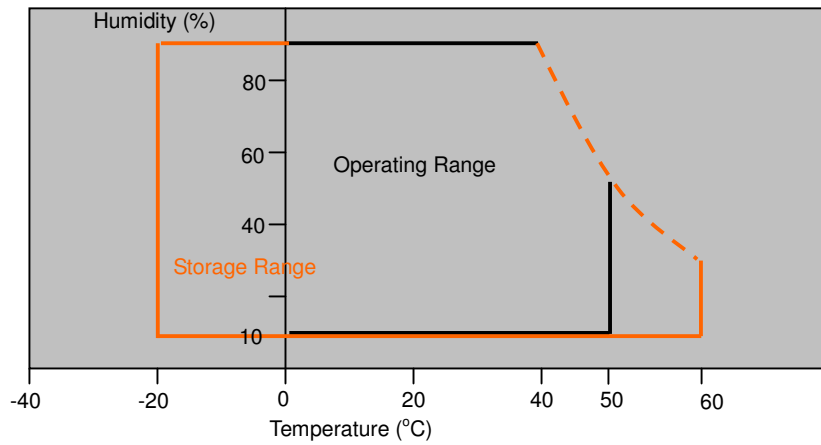

Note .Max wet bulb temp.=39°C

Document Title	HSD101PFW4-B Product Information for Solomon	Page No.	23/28
Document No.		Revision	1.5

8.0 OUTLINE DIMENSION

8.1 Front View Outline Dimension

Unit : mm

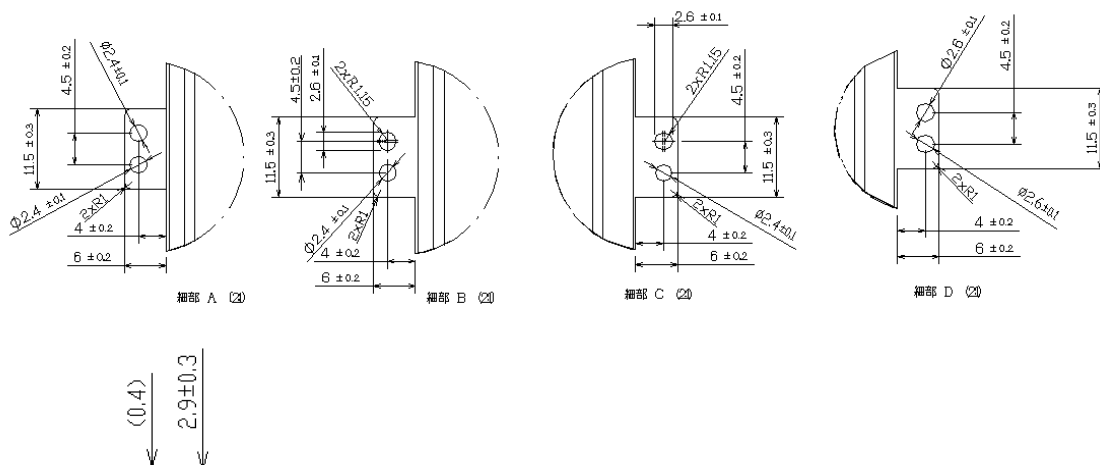
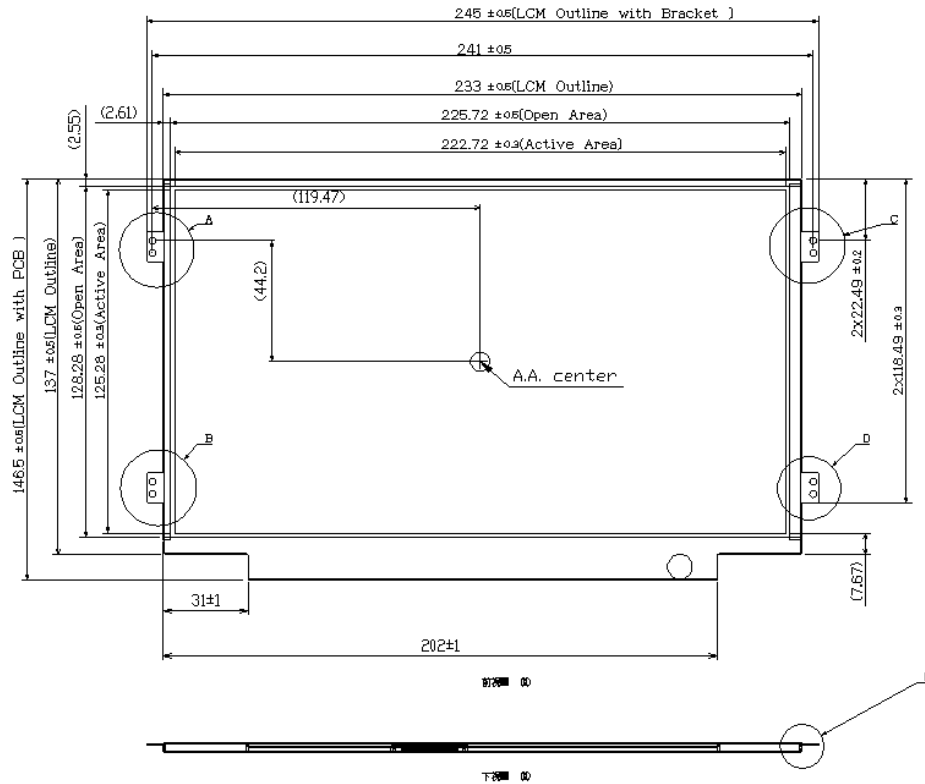

Document Title	HSD101PFW4-B Product Information for Solomon	Page No.	24/28
Document No.		Revision	1.5

8.2 Back View Outline Dimension

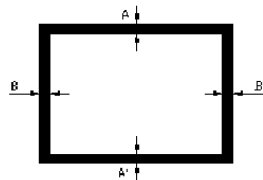
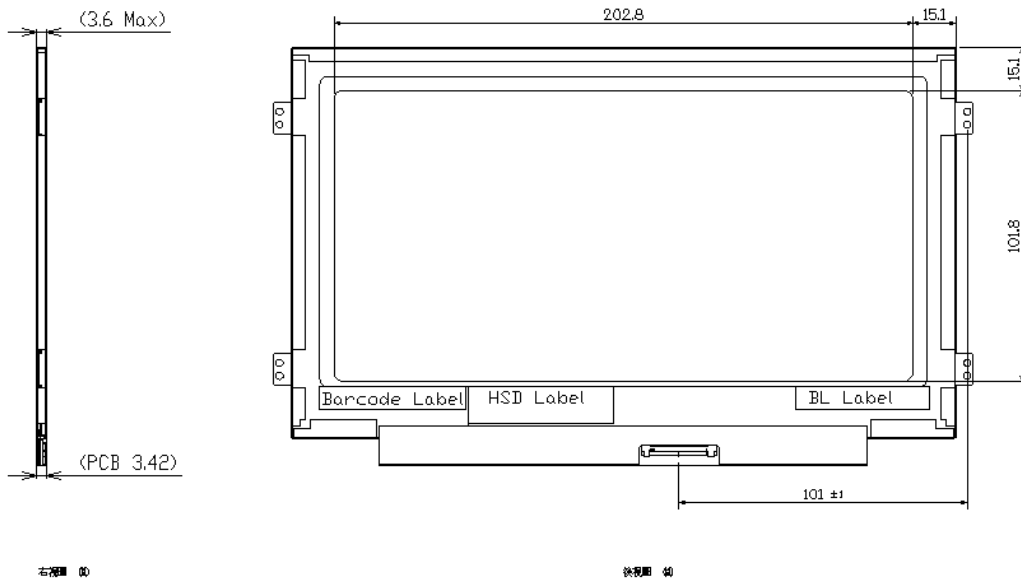

BM Assembly Tolerance

$$|A-A'| \leq 1.0 \text{ (mm)}$$

$$|B-B'| \leq 1.0 \text{ (mm)}$$

Document Title	HSD101PFW4-B Product Information for Solomon	Page No.	25/28
Document No.		Revision	1.5

9.0 LOT MARK

9.1 Lot Mark

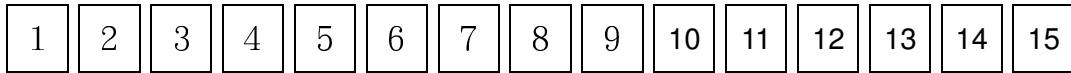

Code 1,2,3,4,5,6: HannStar internal flow control code.

Code 7: production location.

Code 8: production year.

Code 9: production month.

Code 10,11,12,13,14,15: serial number.

Note (1) Production Year

Year	2006	2007	2008	2009	2010	2011	2012	2013	2014	2015
Mark	6	7	8	9	0	1	2	3	4	5

Note (2) Production Month

Month	Jan.	Feb.	Mar.	Apr.	May.	Jun.	Jul.	Aug.	Sep.	Oct	Nov.	Dec.
Mark	1	2	3	4	5	6	7	8	9	A	B	C

9.2 Location of Lot Mark

- (1) Location : The label is attached to the backside of the LCD module. See Product back view. (Section 8.0 : OUTLINE DIMENSION)
- (2) Detail of the Mark : As attached below
- (3) This is subject to change without prior notice.

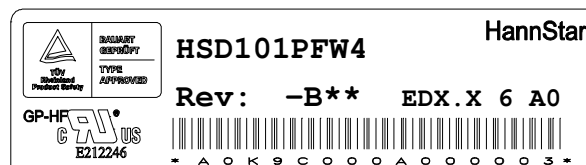

Document Title	HSD101PFW4-B Product Information for Solomon	Page No.	26/28
Document No.		Revision	1.5

10.0 PACKAGE SPECIFICATION

10.1 Packing form

LCM Model	LCM Qty. in the box	Inner Box Size (mm)	Notice
HSD101PFW4-B	30pcs/box	565x316 x240 ^H	

10.2 Packing assembly drawings

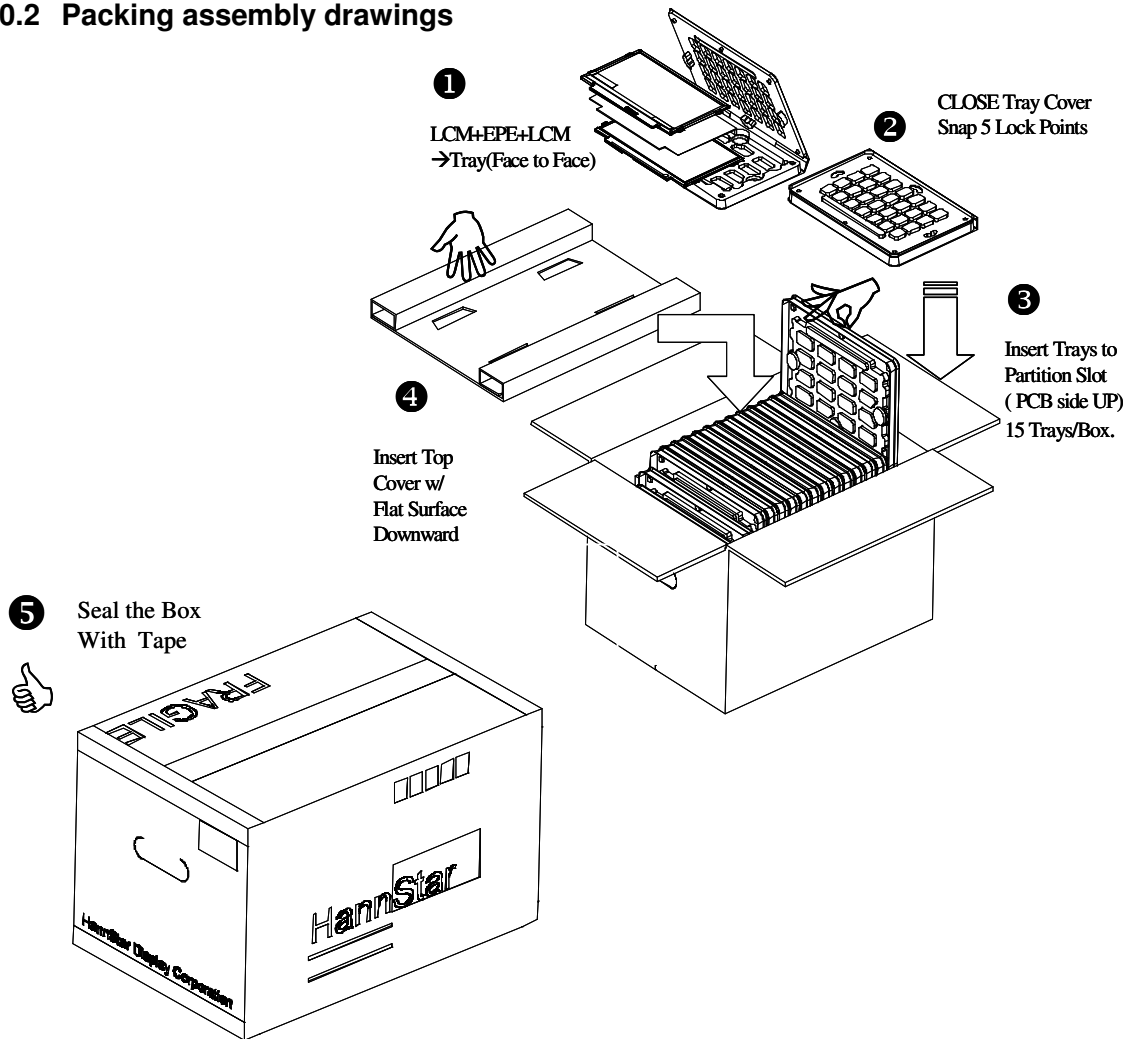

HSD101PFW4-B	Material	Notice
Box	Corrugated Paper Board	AB Flute
Partition/Pad	Corrugated Paper Board	B Flute
Pad	Corrugated Paper Board	B Flute
Tray	PE	--
EPE	PET	--



Document Title	HSD101PFW4-B Product Information for Solomon	Page No.	27/28
Document No.		Revision	1.5

11.0 GENERAL PRECAUTION

11.1 Use Restriction

This product is not authorized for use in life supporting systems, aircraft navigation control systems, military systems and any other application where performance failure could be life-threatening or otherwise catastrophic.

11.2 Disassembling or Modification

Do not disassemble or modify the module. It may damage sensitive parts inside LCD module, and may cause scratches or dust on the display. HannStar does not warrant the module, if customers disassemble or modify the module.

11.3 Breakage of LCD Panel

11.3.1. If LCD panel is broken and liquid crystal spills out, do not ingest or inhale liquid crystal, and do not contact liquid crystal with skin.

11.3.2. If liquid crystal contacts mouth or eyes, rinse out with water immediately.

11.3.3. If liquid crystal contacts skin or cloths, wash it off immediately with alcohol and rinse thoroughly with water.

11.3.4. Handle carefully with chips of glass that may cause injury, when the glass is broken.

11.4 Electric Shock

11.4.1. Disconnect power supply before handling LCD module.

11.4.2. Do not pull or fold the LED cable.

11.4.3. Do not touch the parts inside LCD modules and the fluorescent LED's connector or cables in order to prevent electric shock.

11.5 Absolute Maximum Ratings and Power Protection Circuit

11.5.1. Do not exceed the absolute maximum rating values, such as the supply voltage variation, input voltage variation, variation in parts' parameters, environmental temperature, etc., otherwise LCD module may be damaged.

11.5.2. Please do not leave LCD module in the environment of high humidity and high temperature for a long time.

11.5.3. It's recommended to employ protection circuit for power supply.

11.6 Operation

11.6.1 Do not touch, push or rub the polarizer with anything harder than HB pencil lead.

11.6.2 Use fingerstalls of soft gloves in order to keep clean display quality, when persons handle the LCD module for incoming inspection or assembly.

11.6.3 When the surface is dusty, please wipe gently with absorbent cotton or other soft material.

Document Title	HSD101PFW4-B Product Information for Solomon	Page No.	28/28
Document No.		Revision	1.5

11.6.4 Wipe off saliva or water drops as soon as possible. If saliva or water drops contact with polarizer for a long time, they may cause deformation or color fading.

11.6.5 When cleaning the adhesives, please use absorbent cotton wetted with a little petroleum benzene or other adequate solvent.

11.7 Mechanism

Please mount LCD module by using mounting holes arranged in four corners tightly.

11.8 Static Electricity

11.8.1 Protection film must be removed very slowly from the surface of LCD module to prevent electrostatic occurrence.

11.8.2 Because LCD module uses CMOS-IC on circuit board and TFT-LCD panel, it is very weak to electrostatic discharge. Please be careful with electrostatic discharge. Persons who handle the module should be grounded through adequate methods.

11.9 Strong Light Exposure

The module shall not be exposed under strong light such as direct sunlight. Otherwise, display characteristics may be changed.

11.10 Disposal

When disposing LCD module, obey the local environmental regulations.