



Document Title	HSD100IFW4-A Formal Specification	Page No.	1/24
Document No.	DC140-000814	Revision	1.2

TO :

Date : Feb., 17, 2011

HannStar Product Specification (Formal)

Model: **HSD100IFW4**
-A**

Note:

- (1) Please contact HannStar Display Corp. before designing your product based on this module specification.
- (2) The information contained herein is presented merely to indicate the characteristics and performance of our products. No responsibility is assumed by HannStar for any intellectual property claims or other problems that may result from application based on the module described herein.
- (3) The mark “ ** ” of Model means sub-model code.



Document Title	HSD100IFW4-A Formal Specification	Page No.	2/24
Document No.	DC140-000814	Revision	1.2

Record of Revisions

Rev.	Date	Sub-Model	Description of change
1.0	Oct., 11, 2010	A**	Formal Product Specification was first released.
1.1	Dec., 07,2010	A**	P6. Modify view angle & Optima View Direction
1.2	Feb., 17,2011	A**	P12 Add Pin 23 Pin define



Document Title	HSD100IFW4-A Formal Specification	Page No.	3/24
Document No.	DC140-000814	Revision	1.2

Contents

1.0	General description	p.4
2.0	Absolute maximum ratings.....	p.5
3.0	Optical characteristics.....	p.6
4.0	Block diagram	p.10
5.0	Interface pin connection	p.12
6.0	Electrical characteristics	p.14
7.0	Reliability test items	p.21
8.0	Outline dimension	p.22
9.0	Lot mark	p.24
10.0	Package specification	p.25
11.0	General precaution	p.26

Document Title	HSD100IFW4-A Formal Specification	Page No.	4/24
Document No.	DC140-000814	Revision	1.2

1.0 GENERAL DESCRIPTION

1.1 Introduction

HannStar Display model HSD100IFW4-A is a color active matrix thin film transistor (TFT) liquid crystal display (LCD) that uses amorphous silicon TFT as a switching device. This model is composed of a TFT LCD panel, a driving circuit and a back light system. This TFT LCD has a 10.1 (17:10) inch diagonally measured active display area with WSVGA (1024 horizontal by 600 vertical pixel) resolution.

1.2 Features

- 10 (17:10 diagonal) inch configuration
- One channel LVDS interface
- 262K color by 6 bit R.G.B signal input
- RoHS Compliance
- Halogen Free

1.3 Applications

- Mobile NB
- Digital Photo frame
- Display terminal for AV application

1.4 General information

Item	Specification	Unit
Outline Dimension	235 x 145.8 x 5.5 (Typ.)	mm
Display area	220.416(H) x 129.15(V)	mm
Number of Pixel	1024 RGB (H) x 600(V)	pixels
Pixel pitch	0.21525(H) x 0.21525(V)	mm
Pixel arrangement	RGB Vertical stripe	
Display mode	Normally white	
Surface treatment	Antiglare, Hard-Coating (3H) with EWV film	
Weight	235 (Typ.)	g
Back-light	Single LED (Side-Light type)	
Power Consumption	Logic System 0.5W (Max.) L0 pattern	W

Document Title	HSD100IFW4-A Formal Specification	Page No.	5/24
Document No.	DC140-000814	Revision	1.2

1.5 Mechanical Information

Item		Min.	Typ.	Max.	Unit
Module Size	Horizontal (H)	234.5	235	235.5	mm
	Vertical (V)	145.3	145.8	146.3	mm
	Depth (D)	—	5.5	5.8	mm
Weight		—	235	252	g

2.0 ABSOLUTE MAXIMUM RATINGS

2.1 Electrical Absolute Rating

2.1.1 TFT LCD Module

Item	Symbol	Min.	Max.	Unit	Note
LED Power Supply voltage	V_{LED}	-0.3	6.0	V	GND=0
Logic Supply voltage	V_{DD}	-0.3	6.0	V	

2.1.2 Environment Absolute Rating

Item	Symbol	Min.	Max.	Unit	Note
Operating Temperature	T_{opa}	0	50	°C	
Storage Temperature	T_{stg}	-20	60	°C	

Document Title	HSD100IFW4-A Formal Specification	Page No.	6/24
Document No.	DC140-000814	Revision	1.2

3.0 OPTICAL CHARACTERISTICS

3.1 Optical specification

Item	Symbol	Condition	Min.	Typ.	Max.	Unit	Note	
Contrast	CR	$\Theta=0$ Normal viewing angle	400	500	—		(1)(2)(4)	
Response time	Rising		T_R	—	3	6	msec	(1)(3)
	Falling		T_F	—	9	18		
White luminance (Center)	Y_L			160	200	—	cd/m ²	(1)(4) ($I_L=160mA$)
Color chromaticity (CIE1931)	White	W_x	0.260	0.310	0.360			
		W_y	0.280	0.330	0.380			
Viewing angle	Hor.	Θ_L	60	70	—		(1)(4)	
		Θ_R	60	70	—			
	Ver.	Θ_U	50	60	—			
		Θ_D	40	50	—			
Brightness uniformity	B_{UNI}	$\Theta=0$	70	—	—	%	(5)	
Optima View Direction	12 O' clock						(6)	

3.2 Measuring Condition

- Measuring surrounding : dark room
- LED current I_L : 160mA
- Ambient temperature : $25\pm 2^\circ C$
- 15min. warm-up time.

Document Title	HSD100IFW4-A Formal Specification	Page No.	7/24
Document No.	DC140-000814	Revision	1.2

3.3 Measuring Equipment

- FPM520 of Westar Display technologies, INC., which utilized SR-3 for Chromaticity and BM-5A for other optical characteristics.
- Measuring spot size : 20 ~ 21 mm

Note (1) Definition of Viewing Angle:

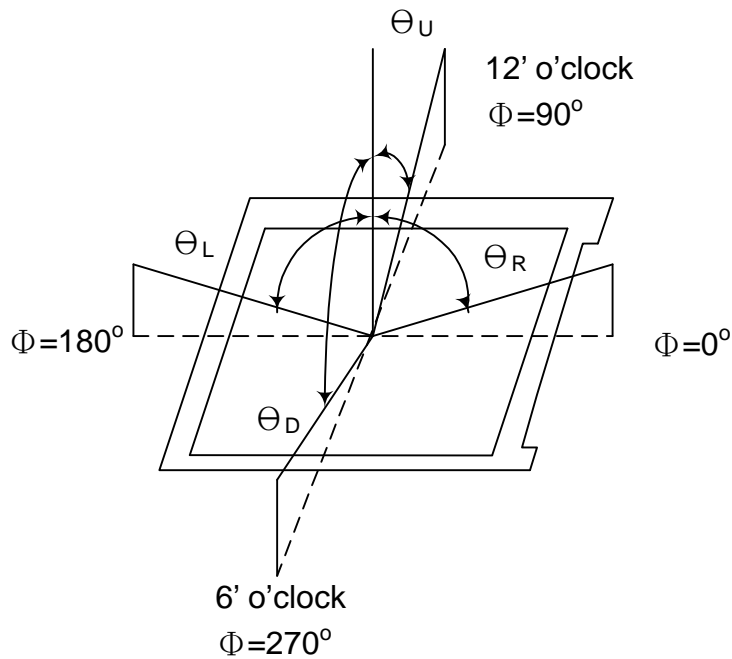

Note (2) Definition of Contrast Ratio (CR) :
measured at the center point of panel

$$CR = \frac{\text{Luminance with all pixels white}}{\text{Luminance with all pixels black}}$$

Document Title	HSD100IFW4-A Formal Specification	Page No.	8/24
Document No.	DC140-000814	Revision	1.2

Note (3) Definition of Response Time : Sum of T_R and T_F

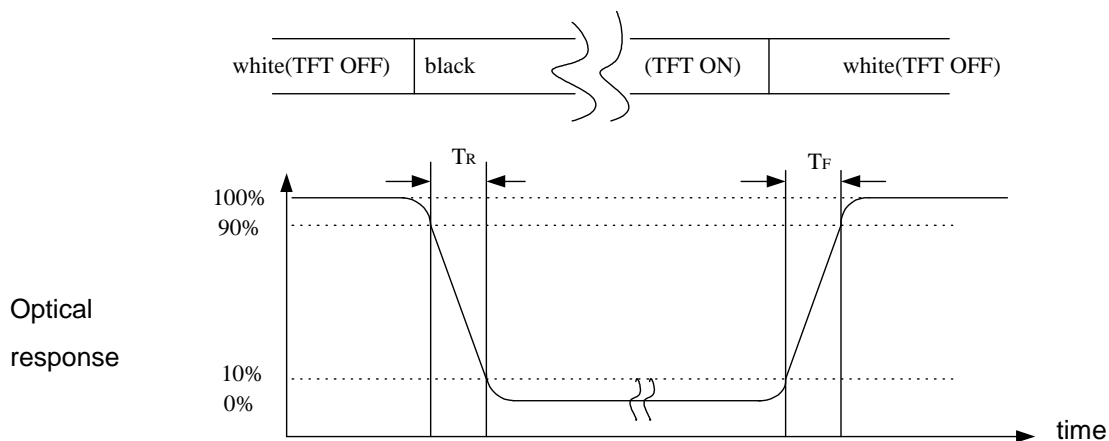

Note (4) Definition of optical measurement setup

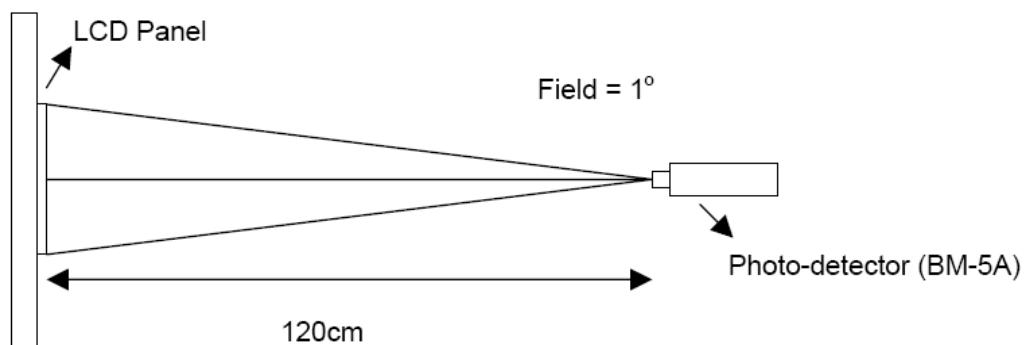

Document Title	HSD100IFW4-A Formal Specification	Page No.	9/24
Document No.	DC140-000814	Revision	1.2

Note (5) Definition of brightness uniformity

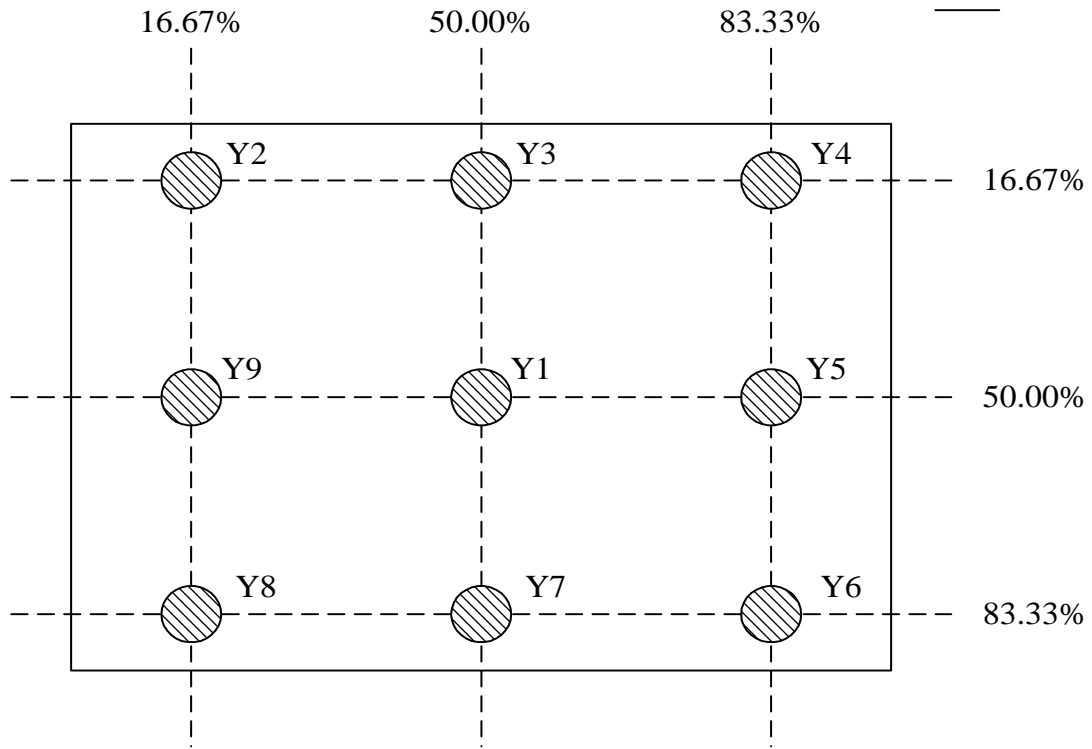

$$\text{Luminance uniformity} = \frac{(\text{Min Luminance of 9 points})}{(\text{Max Luminance of 9 points})} \times 100\%$$

Note (6) : Rubbing Direction :The different Rubbing Direction will cause the different optima view direction.

Document Title	HSD100IFW4-A Formal Specification	Page No.	10/24
Document No.	DC140-000814	Revision	1.2

4.0 BLOCK DIAGRAM

4.1 TFT LCD Module:

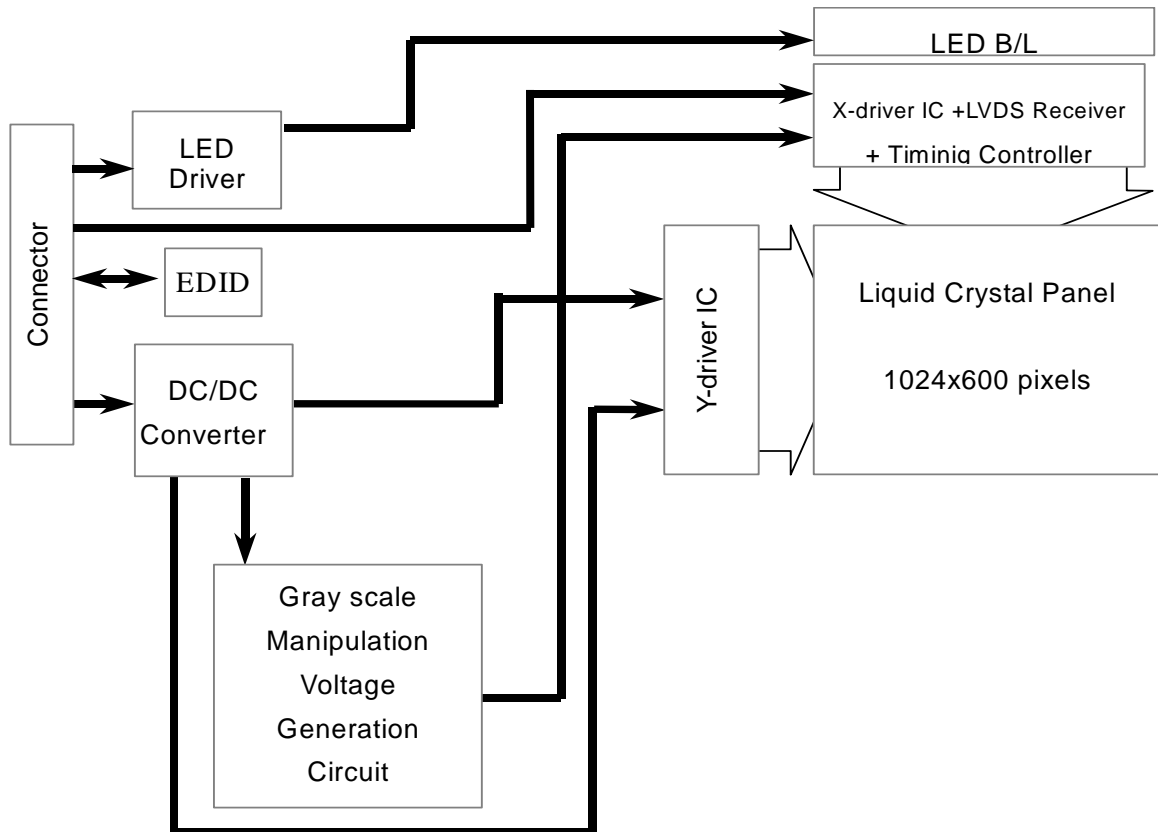

4.2 Pixel Format

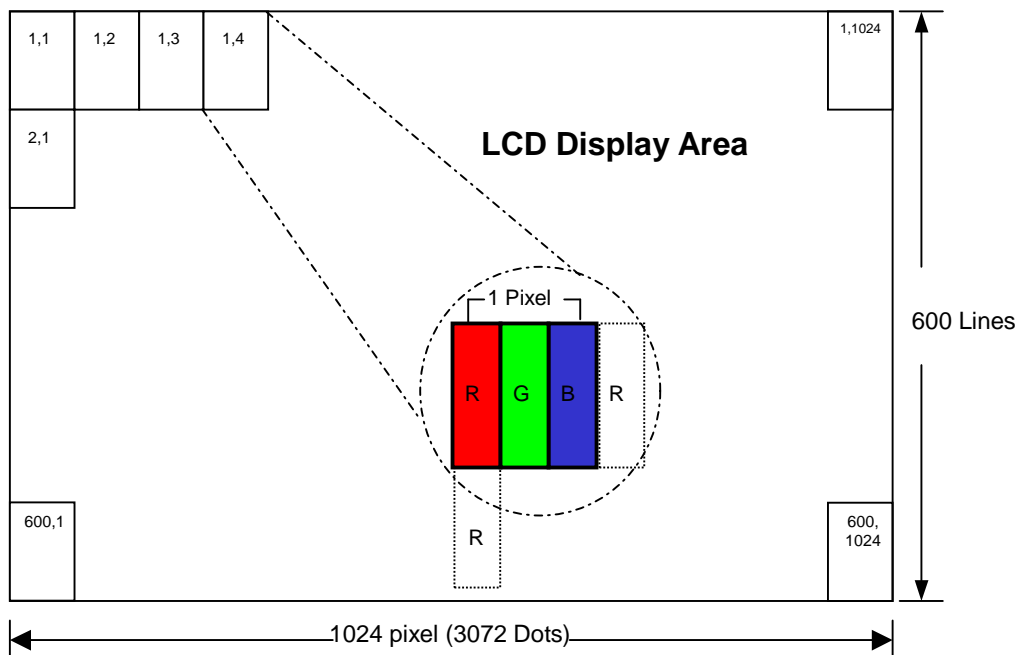

Document Title	HSD100IFW4-A Formal Specification	Page No.	11/24
Document No.	DC140-000814	Revision	1.2

4.3 Relationship Between Displayed Color and Input

	Display	MSB						LSB						Gray scale level						
		R5	R4	R3	R2	R1	R0	G5	G4	G3	G2	G1	G0		B5	B4	B3	B2	B1	B0
Basic color	Black	L	L	L	L	L	L	L	L	L	L	L	L	L	L	L	L	L	L	-
	Blue	L	L	L	L	L	L	L	L	L	L	L	L	H	H	H	H	H	H	-
	Green	L	L	L	L	L	L	H	H	H	H	H	H	L	L	L	L	L	L	-
	Light Blue	L	L	L	L	L	L	H	H	H	H	H	H	H	H	H	H	H	H	-
	Red	H	H	H	H	H	H	L	L	L	L	L	L	L	L	L	L	L	L	-
	Purple	H	H	H	H	H	H	L	L	L	L	L	L	H	H	H	H	H	H	-
	Yellow	H	H	H	H	H	H	H	H	H	H	H	H	L	L	L	L	L	L	-
	White	H	H	H	H	H	H	H	H	H	H	H	H	H	H	H	H	H	H	-
Gray scale of Red	Black	L	L	L	L	L	L	L	L	L	L	L	L	L	L	L	L	L	L	L0
	Dark ↑ ↓ Light	L	L	L	L	L	H	L	L	L	L	L	L	L	L	L	L	L	L	L1
		L	L	L	L	H	L	L	L	L	L	L	L	L	L	L	L	L	L	L2
		⋮	⋮	⋮	⋮	⋮	⋮	⋮	⋮	⋮	⋮	⋮	⋮	⋮	⋮	⋮	⋮	⋮	⋮	L3...L60
		H	H	H	H	L	H	L	L	L	L	L	L	L	L	L	L	L	L	L61
	H	H	H	H	H	L	L	L	L	L	L	L	L	L	L	L	L	L	L62	
	Red	H	H	H	H	H	H	L	L	L	L	L	L	L	L	L	L	L	L	Red L63
	Gray scale of Green	Black	L	L	L	L	L	L	L	L	L	L	L	L	L	L	L	L	L	L
Dark ↑ ↓ Light		L	L	L	L	L	L	L	L	L	L	L	H	L	L	L	L	L	L	L1
		L	L	L	L	L	L	L	L	L	L	L	H	L	L	L	L	L	L	L2
		⋮	⋮	⋮	⋮	⋮	⋮	⋮	⋮	⋮	⋮	⋮	⋮	⋮	⋮	⋮	⋮	⋮	⋮	L3...L60
		L	L	L	L	L	L	H	H	H	H	L	H	L	L	L	L	L	L	L61
L		L	L	L	L	L	H	H	H	H	H	L	L	L	L	L	L	L	L62	
Green		L	L	L	L	L	L	H	H	H	H	H	H	L	L	L	L	L	Green L63	
Gray scale of Blue		Black	L	L	L	L	L	L	L	L	L	L	L	L	L	L	L	L	L	L
	Dark ↑ ↓ Light	L	L	L	L	L	L	L	L	L	L	L	L	L	L	L	L	L	H	L1
		L	L	L	L	L	L	L	L	L	L	L	L	L	L	L	L	H	L	L2
		⋮	⋮	⋮	⋮	⋮	⋮	⋮	⋮	⋮	⋮	⋮	⋮	⋮	⋮	⋮	⋮	⋮	⋮	L3...L60
		L	L	L	L	L	L	L	L	L	L	L	L	H	H	H	H	L	H	L61
	L	L	L	L	L	L	L	L	L	L	L	L	H	H	H	H	H	L	L62	
	Blue	L	L	L	L	L	L	L	L	L	L	L	L	H	H	H	H	H	Blue L63	
	Gray scale of White & Black	Black	L	L	L	L	L	L	L	L	L	L	L	L	L	L	L	L	L	L
Dark ↑ ↓ Light		L	L	L	L	L	H	L	L	L	L	L	H	L	L	L	L	L	H	L1
		L	L	L	L	H	L	L	L	L	L	H	L	L	L	L	L	H	L	L2
		⋮	⋮	⋮	⋮	⋮	⋮	⋮	⋮	⋮	⋮	⋮	⋮	⋮	⋮	⋮	⋮	⋮	⋮	L3...L60
		H	H	H	H	L	H	H	H	H	H	L	H	H	H	H	H	L	H	L61
H		H	H	H	H	L	H	H	H	H	H	L	H	H	H	H	H	L	L62	
White		H	H	H	H	H	H	H	H	H	H	H	H	H	H	H	H	H	White L63	

Document Title	HSD100IFW4-A Formal Specification	Page No.	12/24
Document No.	DC140-000814	Revision	1.2

5.0 INTERFACE PIN CONNECTION

5.1 TFT LCD Module : CN1 (Input signal): FI-XB30SL-HF10 (JAE or equivalent)

Pin No.	Signal	Description
Pin No.	Signal	Description
1	GND	Ground
2	VDD	3.3V Power
3	VDD	3.3V Power
4	V_EDID	3.3V Power for EDID
5	ADJ	Adjust for LED brightness Note
6	CLK_EDID	EDID Clock Input
7	DATA_EDID	EDID Data Input
8	RXIN0-	LVDS Signal - channel0-
9	RXIN0+	LVDS Signal+ channel0+
10	GND	Ground
11	RXIN1-	Data Input channel1-
12	RXIN1+	Data Input channel1+
13	GND	Ground
14	RXIN2-	Data Input channel2-
15	RXIN2+	Data Input channel2+
16	GND	Ground
17	RXCLKIN-	Data Input CLK-
18	RXCLKIN+	Data Input CLK+
19	GND	Ground
20	NC	NC
21	NC	NC
22	GND	Ground
23	GND	Ground
24	VLED	LED Power +5V
25	VLED	LED Power +5V
26	VLED	LED Power +5V
27	NC	NC
28	NC	NC
29	NC	NC
30	NC	NC

Note : The brightness of LCD panel could be changed by adjusting PWM

Document Title	HSD100IFW4-A Formal Specification	Page No.	13/24
Document No.	DC140-000814	Revision	1.2

[Note]

(1) ADJ can adjust brightness to control Pin. Pulse duty the bigger the brighter.

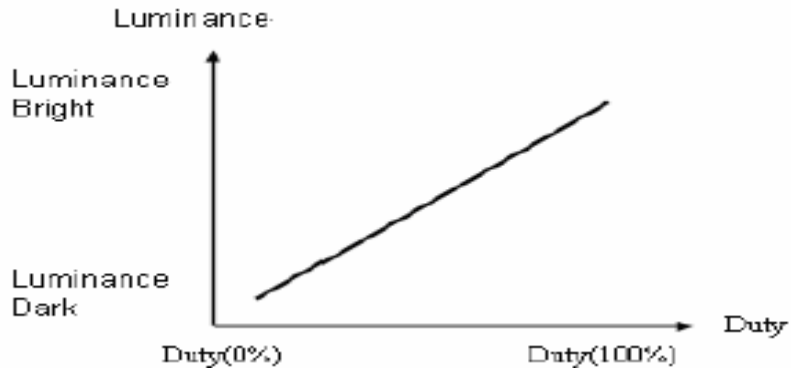

(2) ADJ Signal=0~3.3V · Operation Frequency :

Dimming Range		
PWM Frequency (F)	Duty Cycle (Min.)	Duty Cycle (Max.)
100Hz < F < 500Hz	5%	100%
500Hz < F < 20KHz	10%	100%

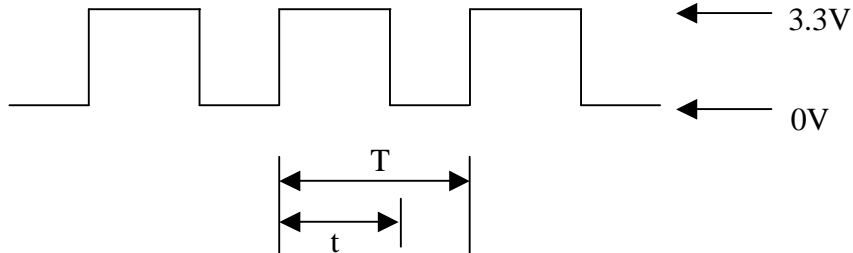

$$\text{Duty Cycle} = t / T * 100\%$$

$$T = 1 / F$$

Document Title	HSD100IFW4-A Formal Specification	Page No.	14/24
Document No.	DC140-000814	Revision	1.2

6.0 ELECTRICAL CHARACTERISTICS

6.1 TFT LCD Module

Item	Symbol	Min.	Typ.	Max.	Unit	Note
Supply Voltage	V_{DD}	3.0	3.3	3.6	V	Note (2)
	V_{LED}	4.7	5.0	5.3	V	
Current of power supply	IDD	-	0.151	-	A	$V_{DD} = 3.3V$ 、L0 pattern
Supply Voltage	V_{DD}	3.0	3.3	3.6	V	Note (2)

Note : (1) The brightness of LCD panel could be changed by adjusting ADJ.

(2) V_{DD} .dip codition :

When V_{DD} operating within $2.7V \leq V_{DD} < 3.0V$, $t_d \leq 10ms$, the display may momentarily become abnormal .

$V_{DD} > 3.0V$, V_{DD} .dip condition should be same as V_{DD} -turn-con condition.

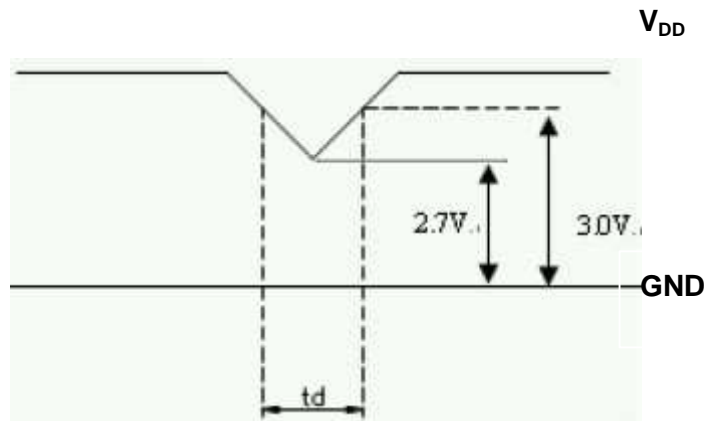

Document Title	HSD100IFW4-A Formal Specification	Page No.	15/24
Document No.	DC140-000814	Revision	1.2

6.2 Switching Characteristics for LVDS Receiver

Item	Symbol	Min.	Typ.	Max.	Unit	Conditions
Differential Input High Threshold	V_{th}	—	—	100	mV	$V_{CM}=1.2V$
Differential Input Low Threshold	V_{tl}	-100	—	—	mV	
Input Current	I_{IN}	-10	—	+10	μA	
Differential input Voltage	$ V_{ID} $	0.2	—	0.6	V	
Common Mode Voltage Offset	V_{CM}	$(V_{ID} /2)$	—	$2.4-(V_{ID} /2)$	V	

6.3 Bit Mapping & Interface Definition

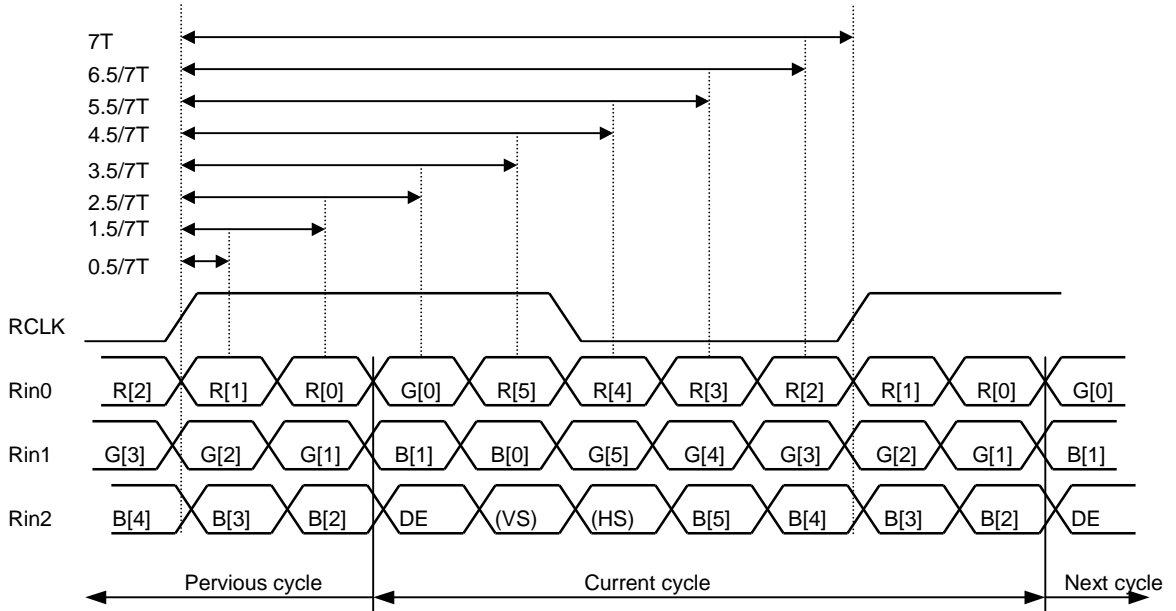

LVDS Receiver Input Timing Definition
for 6bits LVDS input

Document Title	HSD100IFW4-A Formal Specification	Page No.	16/24
Document No.	DC140-000814	Revision	1.2

6.4 Interface Timing (DE mode)

Item	Symbol	Min.	Typ.	Max.	Unit
Frame Rate	--	55	60	65	Hz
Frame Period	t1	612	666	680	line
Vertical Display Time	t2	600	600	600	line
Vertical Blanking Time	t3	12	66	80	line
1 Line Scanning Time	t4	1160	1356	1510	clock
Horizontal Display Time	t5	1024	1024	1024	clock
Horizontal Blanking Time	t6	136	332	486	clock
Clock Rate	t7	39	54.2	61.6	MHz

Timing Diagram of Interface Signal (DE mode)

(1)Vertical

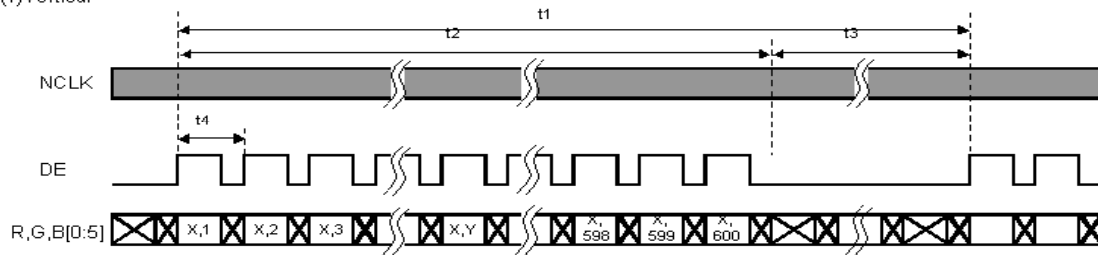

(2)Horizontal

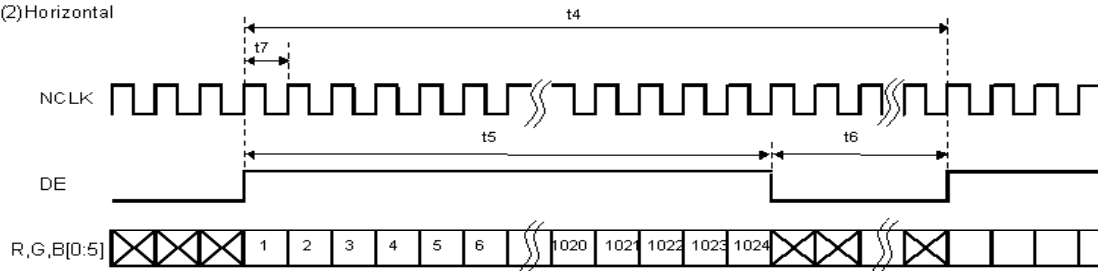

Document Title	HSD100IFW4-A Formal Specification	Page No.	17/24
Document No.	DC140-000814	Revision	1.2

6.5 Power On / Off Sequence

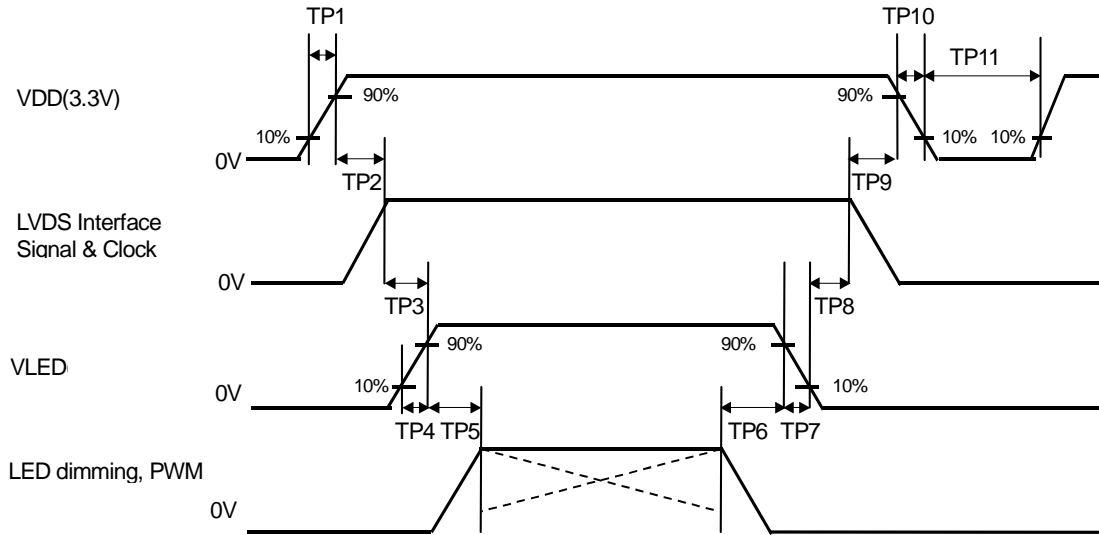

Item	Min.	Typ.	Max.	Unit	Remark
TP1	0.5	--	10	msec	
TP2	0	--	50	msec	
TP3	200	--	--	msec	
TP4	0.5	--	10	msec	
TP5	10	--	--	msec	
TP6	10	--	--	msec	
TP7	0	--	10	msec	
TP8	200	--	--	msec	
TP9	0	--	50	msec	
TP10	1	--	10	msec	

Document Title	HSD100IFW4-A Formal Specification	Page No.	18/24
Document No.	DC140-000814	Revision	1.2

- Note :**
- (1) The supply voltage of the external system for the module input should be the same as the definition of V_{DD} .
 - (2) Apply the lamp voltage within the LCD operation range. When the back-light turns on before the LCD operation or the LCD turns off before the back-light turns off, the display may momentarily become white.
 - (3) In case of V_{DD} = off level, please keep the level of input signal on the low or keep a high impedance.
 - (4) TP11 should be measured after the module has been fully discharged between power off and on period.
 - (5) Interface signal shall not be kept at high impedance when the power is on.
 - (6) The duty of LED dimming signal should be more than 20% in TP4 and TP5
 - (7) PWM can adjust brightness to control Pin. Pulse duty the bigger the brighter

7.0 Reliability test items

No.	Item	Conditions	Remark
1	High Temperature Storage	Ta=+60°C, 240hrs	
2	Low Temperature Storage	Ta=-20°C, 240hrs	
3	High Temperature Operation	Ta=+50°C, 300hrs	
4	Low Temperature Operation	Ta=0°C, 300hrs	
5	High Temperature and High Humidity (operation)	Ta=+50°C, 80%RH, 300hrs	
6	Thermal Cycling Test (non operation)	-20°C(30min) → +60°C(30min), 100 cycles	
7	Electrostatic Discharge	±200V,200pF(0Ω) 1 time/connector	
8	Vibration	1.Random: 1.04G, 10~500Hz, XYZ, 30min/each direction 2.Sine: 1.5G, 5~500Hz, XYZ 30min/each direction	
9	Shock	Half-Sine, 220G, 2ms, ±XYZ, 1time	
10	Vibration (with carton)	Random: 1.04G, 10~500Hz, XYZ, 45min/each direction	
11	Drop (with carton)	Height : 60 cm 1 corner, 3 edges, 6 surfaces	JIS Z0202

Note: There is no display function NG issue occurred, all the cosmetic specification is judged before the reliability stress.

Document Title	HSD100IFW4-A Formal Specification	Page No.	19/24
Document No.	DC140-000814	Revision	1.2

8.0 OUTLINE DIMENSION

8.1 Front View Outline Dimension

Unit : mm

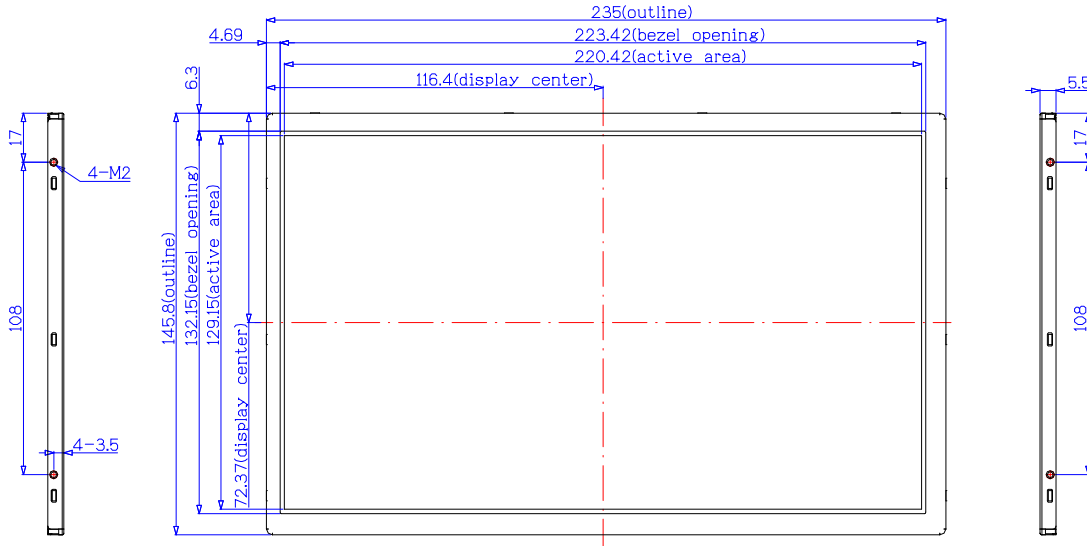

8.2 Back View Outline Dimension

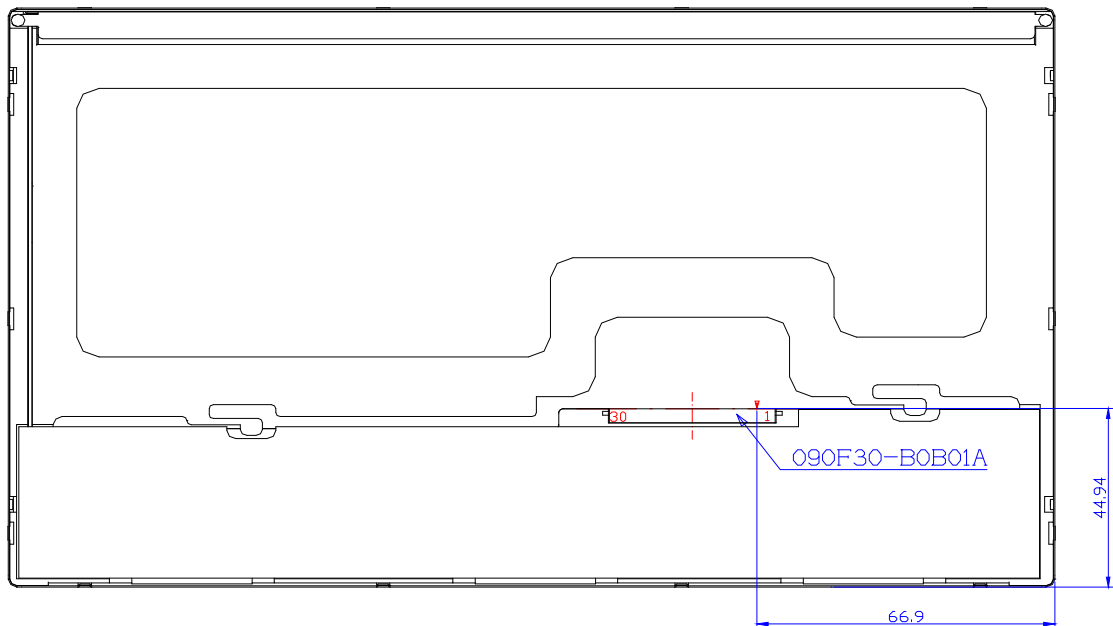

Document Title	HSD100IFW4-A Formal Specification	Page No.	20/24
Document No.	DC140-000814	Revision	1.2

9.0 LOT MARK

9.1 Lot Mark

1	2	3	4	5	6	7	8	9	10	11	12	13	14	15
---	---	---	---	---	---	---	---	---	----	----	----	----	----	----

Code 1,2,3,4,5,6: HannStar internal flow control code.

Code 7: production location.

Code 8: production year.

Code 9: production month.

Code 10,11,12,13,14,15: serial number.

Note (1) Production Year

Year	2006	2007	2008	2009	2010	2011	2012	2013	2014	2015
Mark	6	7	8	9	0	1	2	3	4	5

Note (2) Production Month

Month	Jan.	Feb.	Mar.	Apr.	May.	Jun.	Jul.	Aug.	Sep.	Oct	Nov.	Dec.
Mark	1	2	3	4	5	6	7	8	9	A	B	C

9.2 Location of Lot Mark

(1) The label is attached to the backside of the LCD module.

(2) This is subject to change without prior notice.

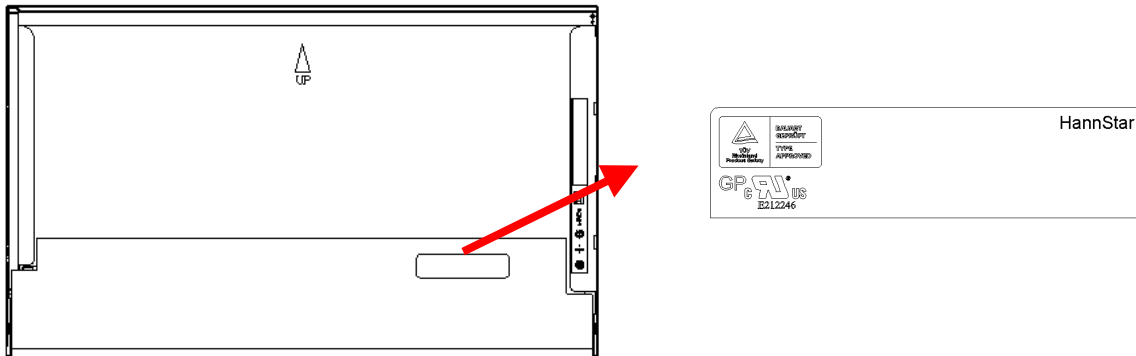

Document Title	HSD100IFW4-A Formal Specification	Page No.	21/24
Document No.	DC140-000814	Revision	1.2

10.0 PACKAGE SPECIFICATION

10.1 Packing form

(1) Package quantity in one carton: 30 pieces.

(2) Carton size: 460 mm×361 mm×321 mm.

10.2 Packing assembly drawings

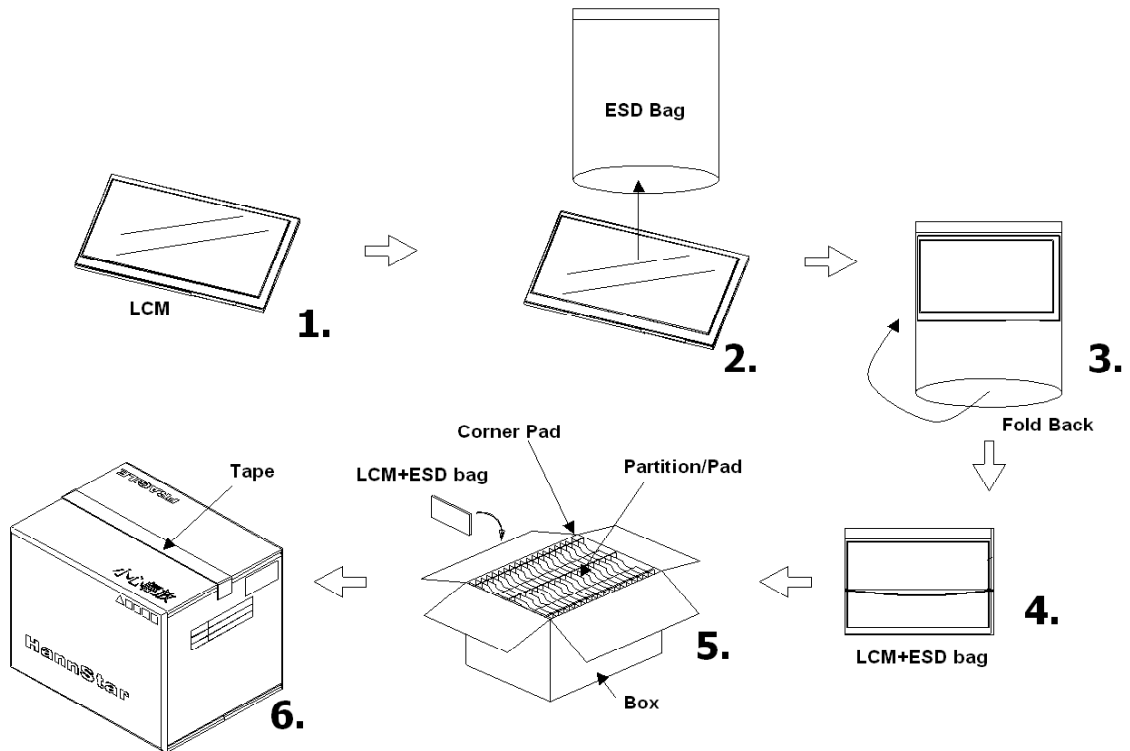

HSD121PHW1-B	Material	Notice
Box	Corrugated Paper Board	(AB Flute)
Partition/Pad	Corrugated Paper Board	(B Flute)
Corner Pad	Corrugated Paper Board	(AB Flute)
ESD bag	PE	--

Document Title	HSD100IFW4-A Formal Specification	Page No.	22/24
Document No.	DC140-000814	Revision	1.2

11.0 GENERAL PRECAUTION

11.1 Use Restriction

This product is not authorized for use in life supporting systems, aircraft navigation control systems, military systems and any other application where performance failure could be life-threatening or otherwise catastrophic.

11.2 Disassembling or Modification

Do not disassemble or modify the module. It may damage sensitive parts inside LCD module, and may cause scratches or dust on the display. HannStar does not warrant the module, if customers disassemble or modify the module.

11.3 Breakage of LCD Panel

11.3.1. If LCD panel is broken and liquid crystal spills out, do not ingest or inhale liquid crystal, and do not contact liquid crystal with skin.

11.3.2. If liquid crystal contacts mouth or eyes, rinse out with water immediately.

11.3.3. If liquid crystal contacts skin or cloths, wash it off immediately with alcohol and rinse thoroughly with water.

11.3.4. Handle carefully with chips of glass that may cause injury, when the glass is broken.

11.4 Electric Shock

11.4.1. Disconnect power supply before handling LCD module.

11.4.2. Do not pull or fold the LED cable.

11.4.3. Do not touch the parts inside LCD modules and the fluorescent LED's connector or cables in order to prevent electric shock.

11.5 Absolute Maximum Ratings and Power Protection Circuit

11.5.1. Do not exceed the absolute maximum rating values, such as the supply voltage variation, input voltage variation, variation in parts' parameters, environmental temperature, etc., otherwise LCD module may be damaged.

11.5.2. Please do not leave LCD module in the environment of high humidity and high temperature for a long time.

11.5.3. It's recommended to employ protection circuit for power supply.

11.6 Operation

11.6.1 Do not touch, push or rub the polarizer with anything harder than HB pencil lead.

11.6.2 Use fingerstalls of soft gloves in order to keep clean display quality, when persons handle the LCD module for incoming inspection or assembly.

11.6.3 When the surface is dusty, please wipe gently with absorbent cotton or other soft material.



Document Title	HSD100IFW4-A Formal Specification	Page No.	23/24
Document No.	DC140-000814	Revision	1.2

11.6.4 Wipe off saliva or water drops as soon as possible. If saliva or water drops contact with polarizer for a long time, they may causes deformation or color fading.

11.6.5 When cleaning the adhesives, please use absorbent cotton wetted with a little petroleum benzine or other adequate solvent.

11.7 Mechanism

Please mount LCD module by using mounting holes arranged in four corners tightly.

11.8 Static Electricity

11.8.1 Protection film must remove very slowly from the surface of LCD module to prevent from electrostatic occurrence.

11.8.2 Because LCD module use CMOS-IC on circuit board and TFT-LCD panel, it is very weak to electrostatic discharge. Please be careful with electrostatic discharge. Persons who handle the module should be grounded through adequate methods.

11.9 Strong Light Exposure

The module shall not be exposed under strong light such as direct sunlight. Otherwise, display characteristics may be changed.

11.10 Disposal

When disposing LCD module, obey the local environmental regulations.



Document Title	HSD100IFW4-A Formal Specification	Page No.	24/24
Document No.	DC140-000814	Revision	1.2

For Special Customer

1.1 General information

Item		Specification	Unit
Outline Dimension		235 x 145.8 x 5.5 (Typ.)	mm
Display area		220.416(H) x 129.15(V)	mm
Number of Pixel		1024 RGB (H) x 600(V)	pixels
Pixel pitch		0.21525(H) x 0.21525(V)	mm
Pixel arrangement		RGB Vertical stripe	
Display mode		Normally white	
Surface treatment		Antiglare, Hard-Coating (3H) with EWV film	
Weight		235 (Typ.)	g
Back-light		Single LED (Side-Light type)	
Power Consumption	Logic System	0.5 (Max.) L0 Pattern	W
	B/L System	2.04 (Max.)	W