



**PROPRIETARY NOTE**

THIS SPECIFICATION IS THE PROPERTY OF BOE-HYDIS AND SHALL NOT BE REPRODUCED OR COPIED WITHOUT THE WRITTEN PERMISSION OF BOE-HYDIS AND MUST BE RETURNED TO BOE-HYDIS UPON ITS REQUEST.

**TITLE: HM17E11-A00**  
**Product Specification**

Rev. A

**BOE-HYDIS TECHNOLOGY CO., LTD.**

<b>SPEC. NUMBER</b>	<b>PRODUCT GROUP</b>	<b>REV.</b>	<b>ISSUE DATE</b>	<b>PAGE</b>
S864 - 1130	TFT-LCD PRODUCT	A	2003.05.28	1 OF 20

**PRODUCT GROUP****REV.****ISSUE DATE**

TFT-LCD PRODUCT

A

2003.05.28

**REVISION HISTORY**

<b>REV.</b>	<b>ECN NO.</b>	<b>DESCRIPTION OF CHANGES</b>	<b>DATE</b>	<b>PREPARED</b>
0		Initial Release	2003.Jan.10	Kim, Jin Tak
A	E305-F008	Changed Composite Sync signal type at page 6 : from OFF mode to 1H mode	2003.May.28	Yoon, Yong Jun

<b>SPEC. NUMBER</b> S864 - 1130	<b>SPEC. TITLE</b> HM17E11-A00 Product Specification	<b>PAGE</b> 2 OF 20
------------------------------------	---	------------------------



**PRODUCT GROUP**

**REV.**

**ISSUE DATE**

TFT-LCD PRODUCT

A

2003.05.28

**Contents**

No.	Item	Page
1.0	GENERAL DESCRIPTION	4
2.0	ABSOLUTE MAXIMUM RATINGS	5
3.0	ELECTRICAL SPECIFICATIONS	6
4.0	OPTICAL SPECIFICATIONS	7
5.0	INTERFACE CONNECTION	9
6.0	MONITOR MODES	11
7.0	OSD FUNCTION	12
8.0	RELIABILITY TEST	13
9.0	ENVIRONMENT & SAFETY	14
10.0	HANDLING & CAUTIONS	15
11.0	APPENDIX	16

**SPEC. NUMBER**

**SPEC. TITLE**

**PAGE**

S864 - 1130

HM17E11-A00 Product Specification

3 OF 20



**PRODUCT GROUP**

**REV.**

**ISSUE DATE**

TFT-LCD PRODUCT

A

2003.05.28

**1.0 GENERAL DESCRIPTION**

1.1 Introduction

HM17E11-A00 is an Intelligent Module™ that is integrating conventional LCM and A/D board. This module has a 17.0 inch diagonally measured active area with SXGA resolutions (1280 x 1024) and can display 16,194,277 colors with Dithering. HM17E11-A00 accepts dual interface that is standard analog RGB, Sync signals and supports from VGA to SXGA resolutions.

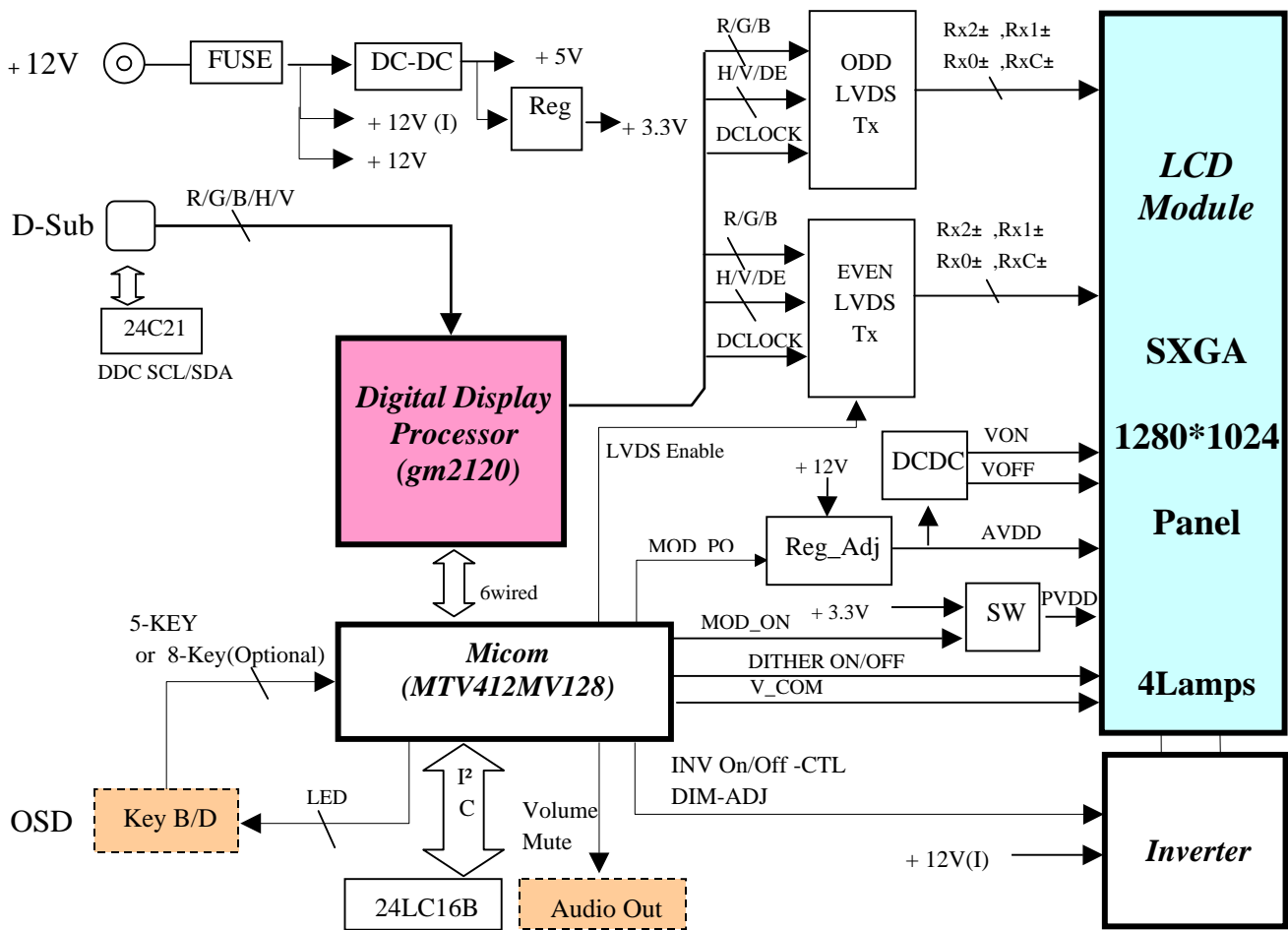

1.2 Features

- Desk-top type of PC Use
- Corresponding to DDC1 and DDC2B
- Corresponding to VESA DPMS
- Multi-scan function: SXGA, XGA, SVGA, VGA
- 16.19M Colors (6bits + FRC2bits)

**SPEC. NUMBER**

S864 - 1130

**SPEC. TITLE**

HM17E11-A00 Product Specification

**PAGE**

4 OF 20

**PRODUCT GROUP****REV.****ISSUE DATE**

TFT-LCD PRODUCT

A

2003.05.28

## 1.3 General Specifications

Parameter	Specification	Unit	Remarks
Active area	337.920(H) × 270.336(V)	mm	
Number of pixels	1280(H) × 1024(V)	pixels	
Pixel pitch	0.264(H) × 0.264(V)	mm	
Pixel arrangement	RGB vertical stripe	-	
Display colors	16.19M (6bits + FRC2bits)	colors	
Display mode	Normally white	-	
Dimensional outline	383.5(H) ±0.5 × 306.0(V) ±0.5 × 30.1(D) typ.	mm	
Weight	2,500 max.	g	
Back-light	Top/Bottom edge side 4-CCFL type	-	Note 1
Surface treatment	Haze 25, Anti-glare & hard-coating 3H	-	

Note:

1. CCFL (Cold Cathode Fluorescent Lamp)

**2.0 ABSOLUTE MAXIMUM RATINGS**

Parameter	Symbol	Min.	Max.	Unit	Remarks
Power Input Voltage	V <sub>DD</sub>	-0.3	14.0	V	Ta = 25°C
Backlight Power Supply Voltage	V <sub>DDB</sub>	-0.3	14.0	V	
Logic Input Voltage	V <sub>IN1</sub>	0.0	3.6	V	Ta = 25°C V <sub>DD</sub> =12V
RGB Input Voltage	V <sub>IN2</sub>	0.0	3.6	V	
Operating Temperature (Humidity)	T <sub>OP</sub>	0	+50	°C	40 °C
	RH		80	%	
Storage Temperature (Humidity)	T <sub>ST</sub>	-20	+60	°C	40 °C
	RH		90	%	

**SPEC. NUMBER**

S864 - 1130

**SPEC. TITLE**

HM17E11-A00 Product Specification

**PAGE**

5 OF 20



**PRODUCT GROUP**

**REV.**

**ISSUE DATE**

TFT-LCD PRODUCT

A

2003.05.28

**3.0 ELECTRICAL SPECIFICATIONS**

The measurement shall be executed after 30 minutes warm-up period

**3.1 Electrical Specifications**

Ta = 25± 2°C

Parameter	Symbol	Min	Typ	Max	Unit	Remark
Input Voltage	VDD	10.8	12.0	13.2	V	
Input Current	IDD		2.6	3.0	A	

**3.2 Video signal (R, G, B) input and Sync Signal Input**

Ta = 25± 2°C

Parameter	Min.	Typ.	Max.	Unit	Remarks	
Maximum Amplitude (white- black)	0 (black)	0.7 (white)	-	Vp-p	Note 1	
Sync	Amplitude	2.0	3.3	5.0	Vp-p	Note 2
	H- Scan Frequency	24.8	-	81.1	KHz	
	V-Scan Frequency	56.2		76.1	Hz	
Sync Process	Separate Signal				Note 3,4	
	Composite Sync.					

Note:

1. Contrast adjustment is needed if the amplitude exceeds 0.7 Vp-p.  
Impedance is 75 Ohm±5%. @Max 50pF
2. Polarity is positive and negative at TTL level  
Impedance is 470-Ohm min. @Max 1000pF
3. Composite Sync signal type is 1H mode.
4. This module is corresponding to the synchronous signal below

Auto recognition mode	Synchronous signal	
	HS/CS	VS
Separate synchronous signal mode	Input	Input
Composite synchronous signal mode	Input (CS)	No input

**3.3 DPMS (Display Power Management Signaling)**

Measuring Condition: VDD=12.0V

Ta = 25± 2°C

VESA DPMS	Signal			Max.	Unit	LED status
	Horizontal	Vertical	Video			
Power On	Pulses	Pulses	Active	33	W	Green
Standby	No Pulses	Pulses	Blanked	1.5	W	Amber or
Suspend	Pulses	No Pulses	Blanked	1.5	W	Amber Blinking
Active Off	No Pulses	No Pulses	Blanked	1.5	W	(Customized spec.)

Note: If video data is inputted at Standby, Suspend and Active Off mode, the system display abnormally or search the mode continuously according to input video data pattern.

**SPEC. NUMBER**

**SPEC. TITLE**

**PAGE**

S864 - 1130

HM17E11-A00 Product Specification

6 OF 20



**PRODUCT GROUP**

**REV.**

**ISSUE DATE**

TFT-LCD PRODUCT

A

2003.05.28

**4.0 OPTICAL SPECIFICATIONS**

The measurement shall be executed after 30 minutes warm-up period.

Measuring equipment : TOPCON -BM5.

- Measuring condition: 1) SXGA 60Hz  
 2) Brightness (Backlight dimming)=maximum  
 3) After auto adjusting contrast

Ta= 25± 2°C

Parameter		Symbol	Condition	Min.	Typ.	Max.	Unit	Remark
Viewing Angle range	Horizontal	$\theta_3$	CR > 10	65	70	-	Deg.	Note 1
		$\theta_9$		65	70	-	Deg.	
	Vertical	$\theta_{12}$		40	45	-	Deg.	
		$\theta_6$		55	65	-	Deg.	
Luminance Contrast ratio		CR	$\theta = 0^\circ$ $\phi = 0^\circ$ IBL=6.0mA	350	450	-		Note 2
Luminance of White		$Y_w$		230	250	-	cd/m <sup>2</sup>	Note 3
White luminance uniformity		Y		-	-	1.18		Note 4
Reproduction Of color	White	$x_w$		0.275	0.305	0.335		Note 5
		$y_w$		0.308	0.338	0.368		
	Red	$x_R$		0.603	0.633	0.663		
		$y_R$		0.324	0.354	0.384		
	Green	$x_G$		0.262	0.292	0.322		
		$y_G$		0.568	0.598	0.628		
	Blue	$x_B$		0.115	0.145	0.175		
		$y_B$	0.077	0.107	0.137			
Response Time (Rise + Decay)		Ttotal	-	25	30	ms	Note 6	
Cross Talk		CT	-	-	2.0	%	Note 7	
Lamp lifetime		Hr	IBL=6.0mA	40,000	50,000	-	hrs	Note 8

**SPEC. NUMBER**

**SPEC. TITLE**

**PAGE**

S864 - 1130

HM17E11-A00 Product Specification

7 OF 20

**PRODUCT GROUP****REV.****ISSUE DATE**

TFT-LCD PRODUCT

A

2003.05.28

## Note:

1. Viewing angle is the angle at which the contrast ratio is greater than 10. The viewing are determined for the horizontal or 3, 9 o'clock direction and the vertical or 6, 12 o'clock direction with respect to the optical axis which is normal to the LCD surface (see FIGURE 1 shown in Appendix).
2. Contrast measurements shall be made at viewing angle of  $\theta = 0^\circ$  and at the center of the LCD surface. Luminance shall be measured with all pixels in the view field set first to white, then to the dark (black) state. (See FIGURE 1 shown in Appendix) Luminance Contrast Ratio (CR) is defined mathematically.

$$CR = \frac{\text{Luminance when displaying a white raster}}{\text{Luminance when displaying a black raster}}$$

3. Center Luminance of white is defined as the LCD surface. Luminance shall be measured with all pixels in the view field set first to white. This measurement shall be taken at the locations shown in FIGURE 2 for a total of the measurements per display.
4. The White luminance uniformity on LCD surface is then expressed as :  $Y = \text{Maximum Luminance of 5 points} / \text{Minimum Luminance of 5 points}$  (see FIGURE 2 shown in Appendix).
5. The color chromaticity coordinates shall be calculated from the spectral data measured with all pixels first in red, green, blue and white. Measurements shall be made at the center of the panel.
6. The electro-optical response time measurements shall be made as FIGURE 3 shown in Appendix by switching the "data" input signal ON and OFF. The times needed for the luminance to change from 10% to 90% is Td, and 90% to 10% is Tr.
7. Cross-Talk of one area of the LCD surface by another shall be measured by comparing the luminance ( $Y_A$ ) of a 25mm diameter area, with all display pixels set to a gray level, to the luminance ( $Y_B$ ) of that same area when any adjacent area is driven dark. (See FIGURE 4 shown in Appendix).
8. Definition of lamp only lifetime is average life shall be defined as remained rate under 50% of total amount at the life test.

**SPEC. NUMBER**

S864 - 1130

**SPEC. TITLE**

HM17E11-A00 Product Specification

**PAGE**

8 OF 20





**PRODUCT GROUP**

**REV.**

**ISSUE DATE**

TFT-LCD PRODUCT

A

2003.05.28

**5.0 INTERFACE CONNECTION**

5.1 Connectors

Part	Description	Pin No	Module Side		User Side	
Analog	CN101	13	S13B-PH-SM3-TB	JST	PHR-13	JST
			Or 1294A-1303R	UJU	Or equivalent	-
Power	CN107	6	S6B-PH-SM3-TB	JST	PHR-6	JST
			Or 1294A-0603R	UJU	Or equivalent	-
OSD	CN104	8	53261-0890	Molex	51021-0800	Molex
					Or equivalent	
Audio	CN108 (Note1)	4	B4B-PH-SM3-TB	JST	PHR-4	JST

Note:

1. Audio function is optional.

5.2 Pin Description

(1) Analog input connector

CN101	Symbol	Function	D-Sub
1	RET	Return	5
2	SCL	DDC Clock	15
3	SDA	DDC Data	12
4	+5V	+5V	9
5	VSY	Vertical Sync	14
6	HSY	Horizontal Sync (Composite Sync.)	13
7	SGND	Sync Ground	10
8	BGND	Blue Ground	8
9	AB	Analog Blue	3
10	GGND	Green Ground	7
11	AG	Analog Green	2
12	RGND	Red Ground	6
13	AR	Analog Red	1

**SPEC. NUMBER**

S864 - 1130

**SPEC. TITLE**

HM17E11-A00 Product Specification

**PAGE**

9 OF 20



**PRODUCT GROUP**

**REV.**

**ISSUE DATE**

TFT-LCD PRODUCT

A

2003.05.28

(2) Power input connector

CN107	Symbol	Function
1	VDD	+12V Power Supply
2	VDD	+12V Power Supply
3	VDD	+12V Power Supply
4	GND	Ground
5	GND	Ground
6	GND	Ground

(3) OSD input connector

CN104	Symbol	Function
1	<b>Menu</b>	Menu Select
2	<b>Select</b>	Select
3	<b>Left</b>	Left Select
4	<b>Right</b>	Right Select
5	LED_G	Green LED On/Off Control
6	LED_R	Green LED On/Off Control
7	Ground	Ground
8	<b>Power</b>	Soft Power On/Off Control
Optional 8Key [Module Side: 53261-1490]		
9	<b>Up</b>	Up Select
10	<b>Down</b>	Down Select
11	GND	Ground
12	LED_IN2	Input LED 1 On/Off Control
13	LED_IN1	Input LED 2 On/Off Control
14	<b>Auto</b>	Auto Adjustment

(4) Audio connector (Optional)

CN108	Symbol	Function
1	VDD	+12V Speaker Power
2	GND	Speaker Ground
3	PWM	Volume Control
4	Mute	Mute Control

**SPEC. NUMBER**

**SPEC. TITLE**

**PAGE**

S864 - 1130

HM17E11-A00 Product Specification

10 OF 20



**PRODUCT GROUP**

**REV.**

**ISSUE DATE**

TFT-LCD PRODUCT

A

2003.05.28

**6.0 MONITOR MODES**

Resolution	Horizontal (KHz)		Vertical (Hz)		PxI Clk (MHz)	Horizontal			Vertical			Remark
	Total	Sync	Total	Sync		BP	Total	Sync	BP			
640 x 350	31.47	+	70.09	-	25.175	800	96	48	449	2	60	VGA
640 x 400	24.83	-	56.42	-	21.053	848	64	84	440	8	32	PC98
	31.47	-	70.09	+	25.175	800	96	48	449	2	35	VGA
640 x 480	31.47	-	59.94	-	25.175	800	96	40	525	2	25	VGA
	37.86	-	72.81	-	31.500	832	40	120	520	3	20	VESA
	37.50	-	75.00	-	31.500	840	64	120	500	3	16	VESA
720 x 400	31.47	-	70.08	+	28.321	900	108	54	449	2	35	US text
800 x 600	35.16	+	56.25	+	36.000	1024	72	128	625	2	22	VESA
	37.88	+	60.32	+	40.000	1056	128	88	628	4	23	VESA
	48.08	+	72.19	+	50.000	1040	120	64	666	6	23	VESA
	46.88	+	75.00	+	49.500	1056	80	160	625	3	21	VESA
1024 x 768	48.36	-	60.00	-	65.000	1344	136	160	806	6	29	VESA
	56.48	-	70.07	-	75.000	1328	136	144	806	6	29	VESA
	60.02	+	75.03	+	78.750	1312	96	176	800	3	28	VESA
1152 x 864	67.50	+	75.00	+	108.000	1600	128	256	900	3	32	VESA
1152 x 900	61.85	CS(-)	66.00	CS(-)	94.500	1528	128	208	937	4	31	SUN
	71.71	CS(-)	76.05	CS(-)	105.561	1472	96	208	943	8	33	SUN
1280 x 960	60.00	+	60.00	+	108.000	1800	112	312	1000	3	36	VESA
1280x1024	63.98	+	60.02	+	108.000	1688	112	248	1066	3	38	VESA
	79.98	+	75.03	+	135.000	1688	144	248	1066	3	38	VESA
	81.13	CS(-)	76.11	CS(-)	135.000	1664	64	288	1066	8	32	SUN

Note:

1. At 640x400-70Hz, OSD Resolution message is 720x400-70Hz.
2. If signal source is not satisfied with VESA timing mode, Auto adjustment cannot work correctly. In that case, use the Clock adjustment and then use Phase adjustment, manually.

**SPEC. NUMBER**

**SPEC. TITLE**

**PAGE**

S864 - 1130

HM17E11-A00 Product Specification

11 OF 20



**PRODUCT GROUP**

**REV.**

**ISSUE DATE**

TFT-LCD PRODUCT

A

2003.05.28

**7.0 OSD FUNCTION**

OSD functions and Key operation are customized specification.

7.1 OSD functions

No.	Menu		Function
1	Auto Adjust		Adjust the clock, phase and position automatically
2	Auto Contrast		Adjust the contrast automatically (Gain control)
3	Brightness		Adjust the Lamp Brightness (Dim control)
4	Contrast		Adjust the contrast (Gain control)
5	H-Position		Adjust the horizontal display position
6	V-Position		Adjust the vertical display position
7	Clock		Adjust the clock frequency
8	Phase		Adjust the clock phase
9	Language		Select the language (English etc)
10	Color Temperature	Warm	Low color temperature (Reddish)
11		Standard	Standard color temperature (Normally)
12		Cool	High color temperature (Bluish)
13		User Red	Control the red color level
14		User Green	Control the green color level
15		User Blue	Control the blue color level
16	OSD H-Position		Move the OSD position horizontally
17	OSD V-Position		Move the OSD position vertically
18	OSD Time		Adjust the OSD off time
19	Power Recall		Remember the last power off condition
20	Transparency		Display the OSD translucently
21	All Reset		Return the value to factory status
22	Save & Exit		Save the set parameter and exit from OSD menu

Note:

1. If satisfactory results are not obtained using the Auto at Clock & Phase, use the Clock adjustment and then use phase, again

7.2 Key operation

Function	Menu	Select	Left	Right	Remark
Self Test			✓	✓	At No Signal
Factory Menu			✓	✓	At Normal Display
Auto Adjust		✓		✓	
Auto Balance		✓	✓		

**SPEC. NUMBER**

**SPEC. TITLE**

**PAGE**

S864 - 1130

HM17E11-A00 Product Specification

12 OF 20



**PRODUCT GROUP**

**REV.**

**ISSUE DATE**

TFT-LCD PRODUCT

A

2003.05.28

**8.0 RELIABILITY TEST**

No	Test Items	Conditions
1	High temperature storage test	Ta = 60 °C, 240 hrs
2	Low temperature storage test	Ta = -20 °C, 240 hrs
3	High temperature & high humidity operation test	Ta = 50 °C, 80 %RH, 240 hrs
4	High temperature operation test	Ta = 50 °C, 240 hrs
5	Low temperature operation test	Ta = 0 °C, 240 hrs
6	Thermal shock	Ta = -20 °C ↔ 60 °C (30 min), 100 cycle
7	Vibration test (Non-operating)	Frequency : 10 ~ 300Hz Gravity/AMP : 1.5G Period : X, Y, Z 30 min
8	Shock test (Non-operating)	Gravity : 70G Pulse width : 11ms, sine wave ± X, ± Y, ± Z Once for each direction
9	Electrostatic discharge test	Air : 150 pF, 330 , 15KV Contact : 150 pF, 330 , 8KV

**SPEC. NUMBER**

**SPEC. TITLE**

**PAGE**

S864 - 1130

HM17E11-A00 Product Specification

13 OF 20



**PRODUCT GROUP**

**REV.**

**ISSUE DATE**

TFT-LCD PRODUCT

A

2003.05.28

**9.0 ENVIRONMENT & SAFETY**

9.1 Mercury Disposal Label

<p>Cold cathode fluorescent lamp in LCD panel contains a small amount of mercury, Please follow local ordinances or regulation for disposal.</p>	<p>該液晶ディスプレイパネルは 光管が組みまれていますので、地方自治の例又は規則に従って棄して下さい。</p>
--	--

9.2 Safety Label (Product Label)

**HM17E11-A00**

MADE IN KOREA      □□□□□□□□□□□□□□□□

Model No.

Lot No.

How to express 'Lot No.'

OO	O	OO	O	OOOOOO	OOOOO
					A serial no. (00001~) (Updated monthly)
					A FG (finished good) code (The last 3 figures of 'Model No.' & Production control No.)
					A production month (1~9,X, Y, Z)
					A production year (The last two figures of the Christian Era)
					A class of product ('T' or 'Q')
					Indication No. for production line

**SPEC. NUMBER**

**SPEC. TITLE**

**PAGE**

S864 - 1130

HM17E11-A00 Product Specification

14 OF 20

**PRODUCT GROUP****REV.****ISSUE DATE**

TFT-LCD PRODUCT

A

2003.05.28

**10.0 HANDLING & CAUTIONS**

## 10.1 Cautions when taking out the module

- Pick the pouch only, when taking out module from a shipping package.

## 10.2 Cautions for handling the module

- As the electrostatic discharges may break the LCD module, handle the LCD module with care. Peel a protection sheet off from the LCD panel surface as slowly as possible.
- As the LCD panel and backlight element are made from fragile glass material, impulse and pressure to the LCD module should be avoided.
- As the surface of the polarizer is very soft and easily scratched, use a soft dry cloth without chemicals for cleaning.
- Do not pull the interface connector in or out while the LCD module is operating.
- Put the module display side down on a flat horizontal plane.
- Handle connectors and cables with care.

## 10.3 Cautions for the operation

- When the module is operating, do not lose synchronous signals. If these signals were lost, the LCD panel would be damaged.
- Obey the supply voltage sequence. If wrong sequence were applied, the module would be damaged.

## 10.4 Cautions for the atmosphere

- Dewdrop atmosphere should be avoided.
- Do not store and/or operate the LCD module in a high temperature and/or humidity atmosphere. Storage in an electro-conductive polymer-packing pouch and under relatively low temperature atmosphere is recommended.

## 10.5 Cautions for the module characteristics

- Do not apply fixed pattern data signal to the LCD module at product aging.
- Applying fixed pattern for a long time may cause image sticking.

## 10.6 Other cautions

- Do not disassemble and/or re-assemble LCD module.
- Do not re-adjust variable resistor or switch etc.
- When returning the module for repair or etc, please pack the module not to be broken. We recommend using the original shipping packages.

**SPEC. NUMBER**

S864 - 1130

**SPEC. TITLE**

HM17E11-A00 Product Specification

**PAGE**

15 OF 20



PRODUCT GROUP

REV.

ISSUE DATE

TFT-LCD PRODUCT

A

2003.05.28

11.0 APPENDIX

Figure 1. Measurement Set Up

Measuring distance: 50Cm  
Field: 2 degree

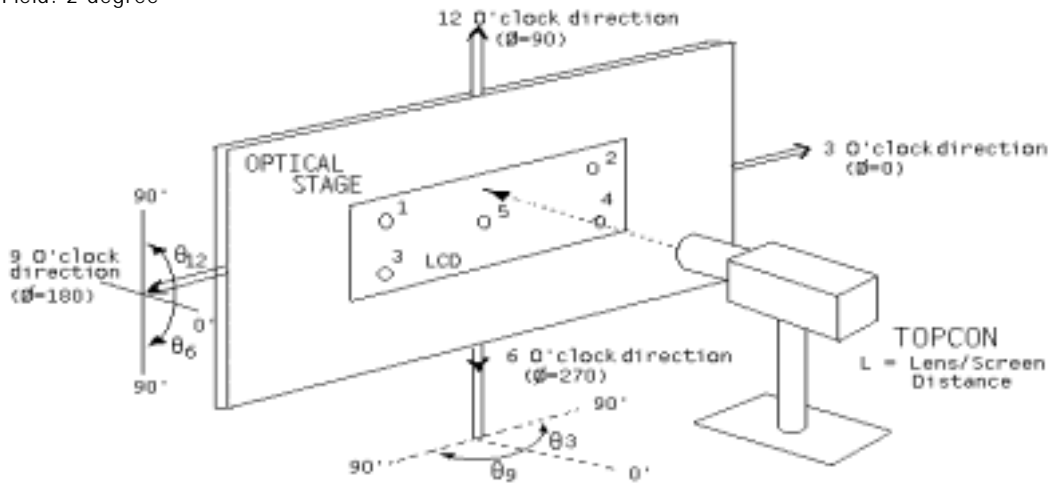
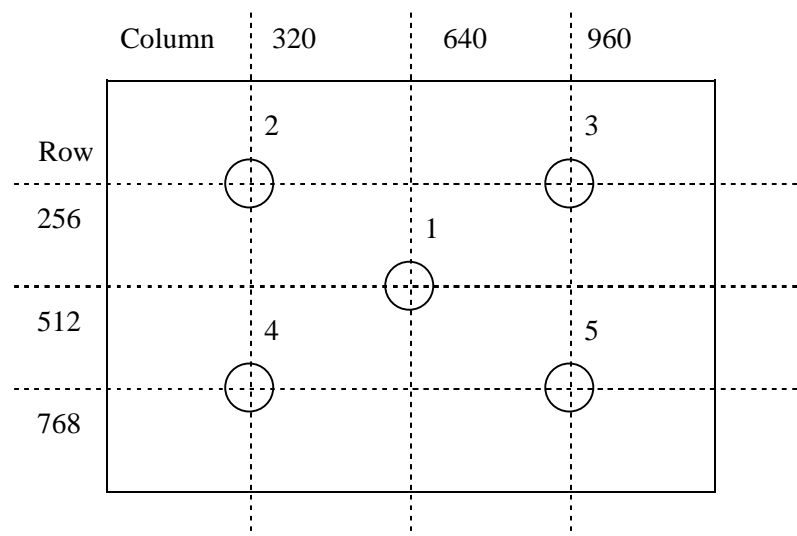

Figure 2. Average Luminance Measurement Locations & Uniformity Measurement Locations



SPEC. NUMBER

S864 - 1130

SPEC. TITLE

HM17E11-A00 Product Specification

PAGE

16 OF 20





**PRODUCT GROUP**

**REV.**

**ISSUE DATE**

TFT-LCD PRODUCT

A

2003.05.28

**Figure 3. Response Time Testing**

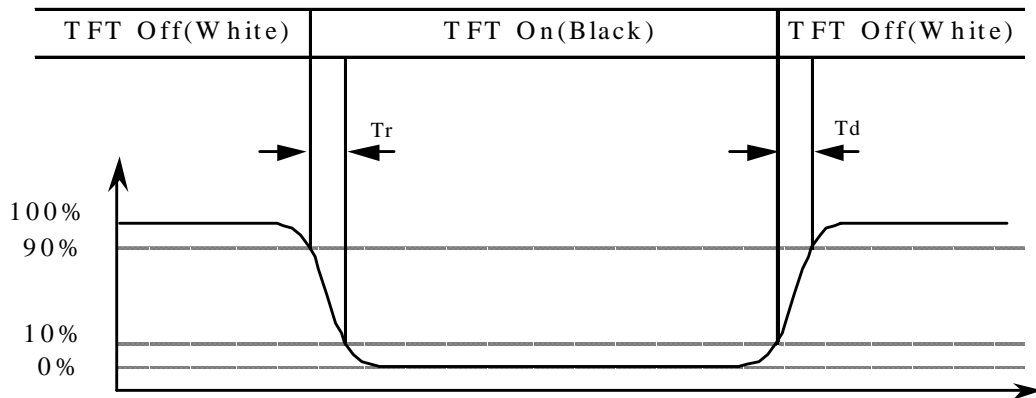

**Figure 4. Cross Modulation Test Description**

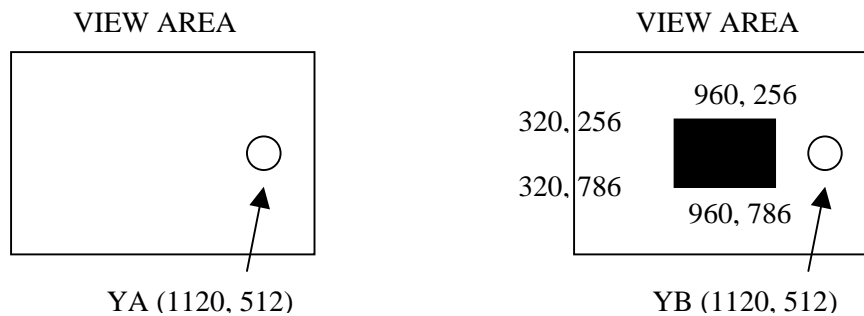

$$\text{Cross-Talk} = \left| \frac{Y_B - Y_A}{Y_A} \right| \times 100$$

Where:

$Y_A$  = Initial luminance of measured area ( $\text{cd}/\text{m}^2$ )

$Y_B$  = Subsequent luminance of measured area ( $\text{cd}/\text{m}^2$ )

The location measured will be exactly the same in both patterns.

**SPEC. NUMBER**

S864 - 1130

**SPEC. TITLE**

HM17E11-A00 Product Specification

**PAGE**

17 OF 20



PRODUCT GROUP

REV.

ISSUE DATE

TFT-LCD PRODUCT

A

2003.05.28

Figure 5. TFT-LCD Module Outline Dimensions (Front view)

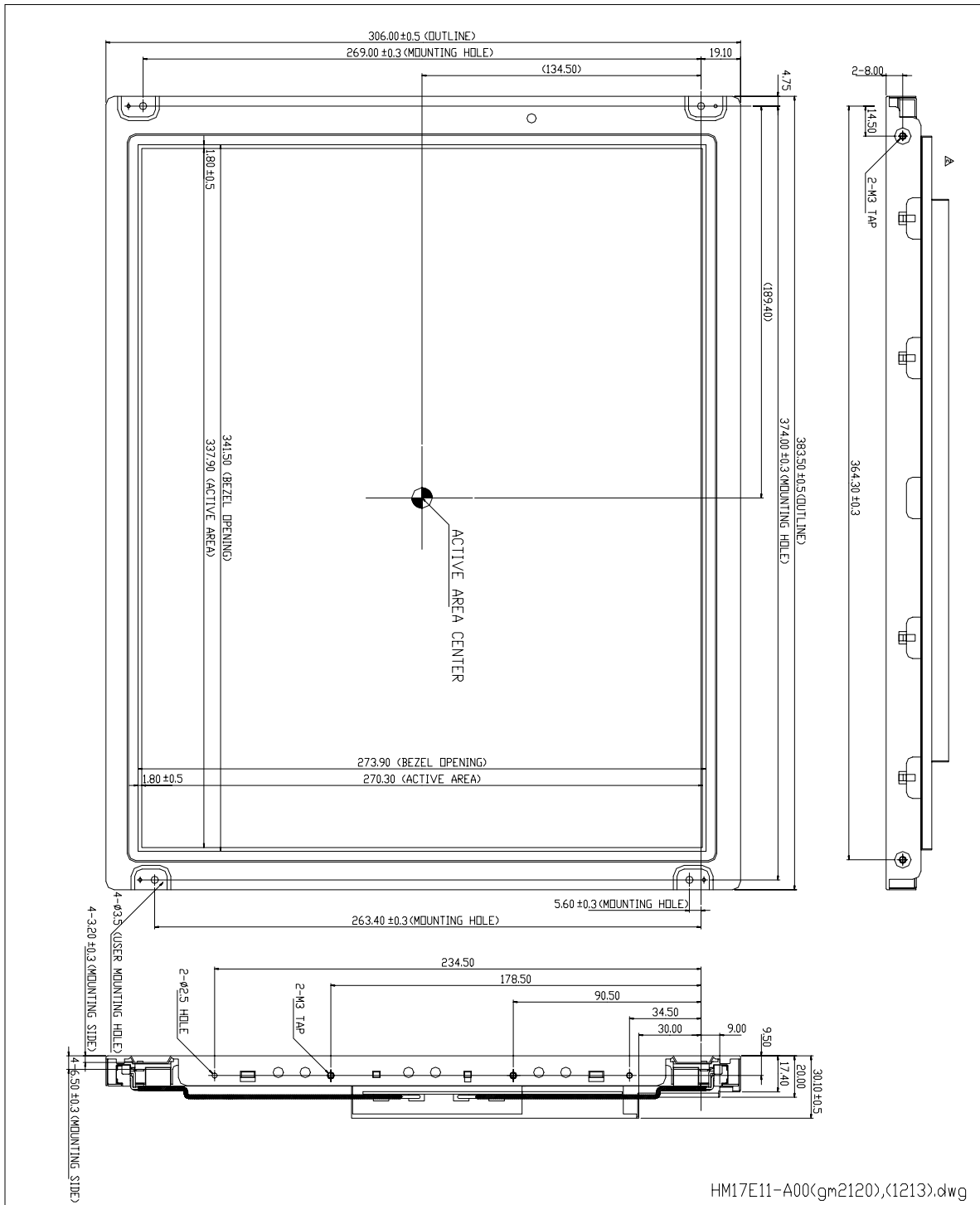

SPEC. NUMBER

SPEC. TITLE

PAGE

S864 - 1130

HM17E11-A00 Product Specification

18 OF 20



PRODUCT GROUP

REV.

ISSUE DATE

TFT-LCD PRODUCT

A

2003.05.28

Figure 6. TFT-LCD Module Outline Dimensions (Rear view)

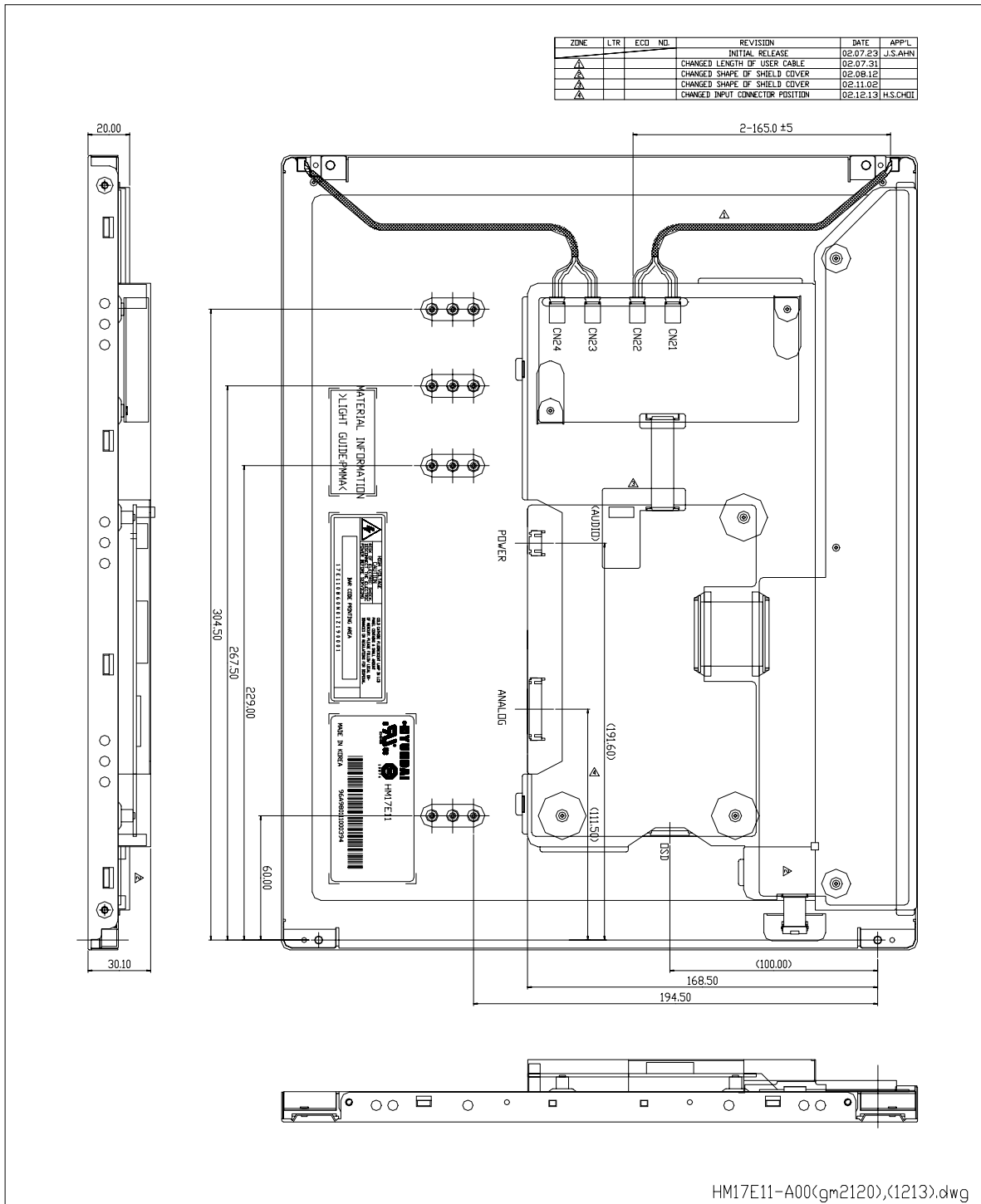

SPEC. NUMBER

S864 - 1130

SPEC. TITLE

HM17E11-A00 Product Specification

PAGE

19 OF 20



**PRODUCT GROUP**

**REV.**

**ISSUE DATE**

TFT-LCD PRODUCT

A

2003.05.28

**Table 1. EDID Firmware Content**

Address	No. Bytes	Description
00h	8	Header
08h	10	Vendor/Product Identification User define, Vendor=<HDS>, default=<blank>
12h	2	EDID Structure Version / Revision User define, Version #=1, Revision #=*
14h	5	Basic Display Parameters / Features Video input definition=Analog & Digital Image size=17.0", Gamma=2.5 Feature support = Standby, Suspend, Active off, RGB
19h	10	Color Characteristics Red x = 0.633, Red y = 0.354 Green x = 0.292, Green y = 0.598 Blue x = 0.145, Blue y = 0.107 White x = 0.305, White y = 0.338
23h	3	Established Timings Established timing I = 720x400@70Hz/ 640x480@60Hz, 72Hz, 75Hz / 800x600@56Hz, 60Hz Established timing II = 800x600@72Hz, 75Hz / 1024x768@60Hz, 70Hz, 75Hz / 1280x1024@75Hz Established timing III
26h	16	Standard Timing Identification Standard timing identification #1~#8, User define
36h	72	Detailed Timing Description Detailed timing description #1~#4 or Monitor Descriptor User define Monitor S/N, ASCII data string, Monitor range limits, Monitor name
7Eh	1	Extension Flag = 0 EDID extension blocks
7Fh	1	Checksum

**SPEC. NUMBER**

**SPEC. TITLE**

**PAGE**

S864 - 1130

HM17E11-A00 Product Specification

20 OF 20