

## TFT LCD Approval Specification

# MODEL NO.: G121X1-L02

Customer: \_\_\_\_\_

Approved by: \_\_\_\_\_

Note:

記錄	工作	審核	角色	投票
2008-12-15 00:02:04 CST	PMMD Director	cs_lee(李志聖 /17564/44926)	Director	Accept

- CONTENTS -

REVISION HISTORY	-----	3
1. GENERAL DESCRIPTION	-----	4
1.1 OVERVIEW		
1.2 FEATURES		
1.3 APPLICATION		
1.4 GENERAL SPECIFICATIONS		
1.5 MECHANICAL SPECIFICATIONS		
2. ABSOLUTE MAXIMUM RATINGS	-----	6
2.1 ABSOLUTE RATINGS OF ENVIRONMENT		
2.2 ELECTRICAL ABSOLUTE RATINGS		
2.2.1 TFT LCD MODULE		
2.2.2 BACKLIGHT UNIT		
3. ELECTRICAL CHARACTERISTICS	-----	7
3.1 TFT LCD MODULE		
3.2 BACKLIGHT UNIT		
4. BLOCK DIAGRAM	-----	11
4.1 TFT LCD MODULE		
4.2 BACKLIGHT UNIT		
5. INPUT TERMINAL PIN ASSIGNMENT	-----	12
5.1 TFT LCD MODULE		
5.2 BACKLIGHT UNIT		
5.3 TIMING DIAGRAM OF LVDS INPUT SIGNAL		
5.4 COLOR DATA INPUT ASSIGNMENT		
6. INTERFACE TIMING	-----	14
6.1 INPUT SIGNAL TIMING SPECIFICATIONS		
6.2 POWER ON/OFF SEQUENCE		
7. OPTICAL CHARACTERISTICS	-----	16
7.1 TEST CONDITIONS		
7.2 OPTICAL SPECIFICATIONS		
8. PACKAGING	-----	20
8.1 PACKING SPECIFICATIONS		
8.2 PACKING METHOD		
9. DEFINITION OF LABELS	-----	22
10. PRECAUTIONS	-----	23
10.1 ASSEMBLY AND HANDLING PRECAUTIONS		
10.2 SAFETY PRECAUTIONS		
11. MECHANICAL CHARACTERISTICS	-----	24

**REVISION HISTORY**

Version	Date	Section	Description
2.0	Nov. 17.2008	All	G121X1-L02 Approval SPEC was first issued

## 1. GENERAL DESCRIPTION

### 1.1 OVERVIEW

The G121X1-L02 model is a 12.1" TFT-LCD module with a 2-CCFL Backlight Unit and a 20-pin 1ch-LVDS interface. This module supports 1024 x 768 XGA mode and displays 262,144 colors. The inverter module for the Backlight Unit is not built in.

### 1.2 FEATURES

- Wide viewing angle
- High contrast ratio
- Fast response time
- XGA (1024 x 768 pixels) resolution
- Wide operating temperature
- DE (Data Enable) mode
- LVDS (Low Voltage Differential Signaling) interface
- RoHS Compliance
- Lamp Replaceable
- Sunlight Readable

### 1.3 APPLICATION

- TFT LCD Monitor
- TFT LCD TV
- Industrial Application
- Amusement
- Vehicle

### 1.4 GENERAL SPECIFICATIONS

Item	Specification	Unit	Note
Diagonal Size	12.1	inch	(1)
Active Area	245.76(H) x 184.32(V)	mm	
Bezel Opening Area	249.0 x 187.5	mm	
Driver Element	a-si TFT active matrix	-	-
Pixel Number	1024 x R.G.B. x 768	pixel	-
Pixel Pitch	0.240(H) x 0.240(V)	mm	-
Pixel Arrangement	RGB vertical stripe	-	-
Display Colors	262,144	color	-
Transmissive Mode	Normally white	-	-
Surface Treatment	Hard coating (3H), Glare	-	-

## 1.5 MECHANICAL SPECIFICATIONS

Item	Min.	Typ.	Max.	Unit	Note	
Module Size	Horizontal (H)	260.2	260.5	260.8	mm	(1)
	Vertical (V)	239.7	204	204.3	mm	
	Depth (D)	11.7	12.2	12.7	mm	
Weight			700	g	-	
I/F connector mounting position	The mounting inclination of the connector makes the screen center within $\pm 0.5\text{mm}$ as the horizontal.			-	(2)	

Note (1) Please refer to the attached drawings for more information of front and back outline dimensions.

(2) Connector mounting position

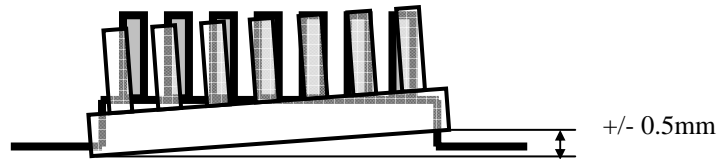

## 2. ABSOLUTE MAXIMUM RATINGS

### 2.1 ABSOLUTE RATINGS OF ENVIRONMENT

Item	Symbol	Value		Unit	Note
		Min.	Max.		
Operating Ambient Temperature	T <sub>OP</sub>	-30	+80	°C	
Storage Temperature	T <sub>ST</sub>	-40	+85	°C	

Test Item	Test Condition	Note
High Temperature Storage Test	85°C, 240 hours	(1)(2)
Low Temperature Storage Test	-40°C, 240 hours	
Thermal Shock Storage Test	-30°C, 0.5hour 80 , 0.5hour; 1hour/cycle,100cycles	
High Temperature Operation Test	80°C, 240 hours	
Low Temperature Operation Test	-30°C, 240 hours	
High Temperature & High Humidity Operation Test	60°C, 90%RH, 240hours	
Shock (Non-Operating)	200G, 2ms, half sine wave, 1 time for ± X, ± Y, ± Z.	
Vibration (Non-Operating)	1.5G, 10 ~ 300 Hz, 10min/cycle, 3 cycles each X, Y, Z	(3)

Note (1) There should be no condensation on the surface of panel during test.

Note (2) Temperature of panel display surface area should be 90 °C Max.

Note (3) At testing Vibration and Shock, the fixture in holding the module has to be hard and rigid enough so that the module would not be twisted or bent by the fixture.

Note (4) In the standard conditions, there is no function failure issue occurred. All the cosmetic specification is judged before the reliability test

### 2.2 ELECTRICAL ABSOLUTE RATINGS

#### 2.2.1 TFT LCD MODULE

Item	Symbol	Value		Unit	Note
		Min.	Max.		
Power Supply Voltage	V <sub>CC</sub>	-0.3	4.0	V	(1)
Logic Input Voltage	V <sub>IN</sub>	-0.3	2.7	V	

#### 2.2.2 BACKLIGHT UNIT

Item	Symbol	Value		Unit	Note
		Min.	Max.		
Lamp Voltage	V <sub>L</sub>	-	2.5K	V <sub>RMS</sub>	(1), (2), I <sub>L</sub> = (8)mA
Lamp Current	I <sub>L</sub>	2.0	8.5	mA <sub>RMS</sub>	(1), (2)
Lamp Frequency	F <sub>L</sub>	45	80	KHZ	

Note (1) Permanent damage to the device may occur if maximum values are exceeded. Function operation should be restricted to the conditions described under Normal Operating Conditions.

Note (2) Specified values are for lamp (Refer to 3.2 for further information).

### 3. ELECTRICAL CHARACTERISTICS

#### 3.1 TFT LCD MODULE

Ta = 25 ± 2 °C

Parameter	Symbol	Value			Unit	Note
		Min.	Typ.	Max.		
Power Supply Voltage	V <sub>CC</sub>	3.0	3.3	3.6	V	-
Ripple Voltage	V <sub>RP</sub>	-	-	100	mV	-
Rush Current	I <sub>RUSH</sub>	-	-	1.0	A	(2)
Power Supply Current	White	-	350	490	mA	(3)a
	Black	-	510	650	mA	(3)b
LVDS differential input voltage	V <sub>id</sub>	-100	-	+100	mV	-
LVDS common input voltage	V <sub>ic</sub>	-	1.2	-	V	-

Note (1) The module is recommended to operate within specification ranges listed above for normal function.

Note (2) Measurement Conditions:

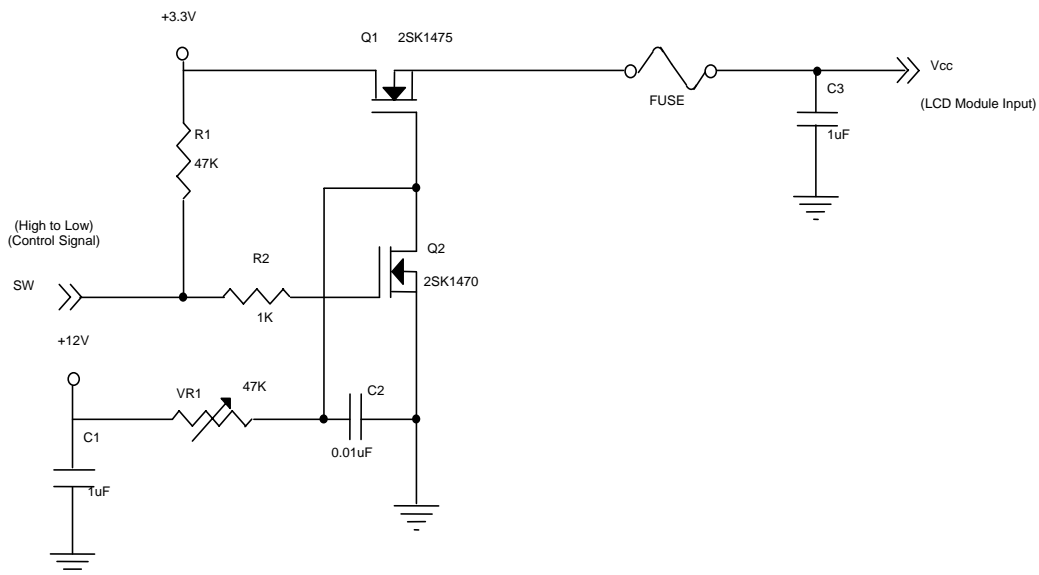

**Vcc rising time is 470μs**

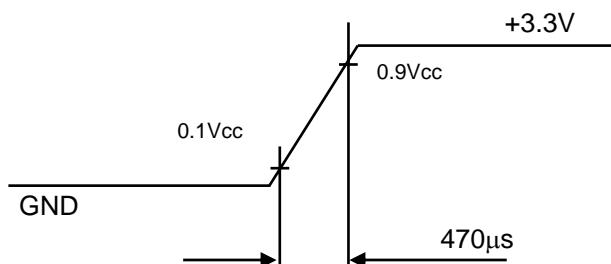

Note (3) The specified power supply current is under the conditions at  $V_{cc} = 3.3\text{ V}$ ,  $T_a = 25 \pm 2\text{ }^\circ\text{C}$ ,  $f_v = 60\text{ Hz}$ , whereas a power dissipation check pattern below is displayed.

a. White Pattern



Active Area

b. Black Pattern



Active Area



### 3.2 BACKLIGHT UNIT

Parameter	Symbol	Value			Unit	Note
		Min.	Typ.	Max.		
Lamp Input Voltage	$V_L$	450	500	550	$V_{RMS}$	$I_L = 8mA$
Lamp Current	$I_L$	2.0	8.0	8.5	$mA_{RMS}$	(1)
Lamp Turn On Voltage	$V_S$	-	-	1010	$V_{RMS}$	25 °C, (2)
		-	-	1200	$V_{RMS}$	0 °C, (2)
Operating Frequency	$F_L$	45	-	80	KHz	(3)
Lamp Life Time	$L_{BL}$	50000	-	-	Hrs	(5), $I_L = 8mA$
Power Consumption	$P_L$	-	4.0	-	W	(4), $I_L = 8mA$

Note (1) Lamp current is measured by utilizing high-frequency current meters as shown below:

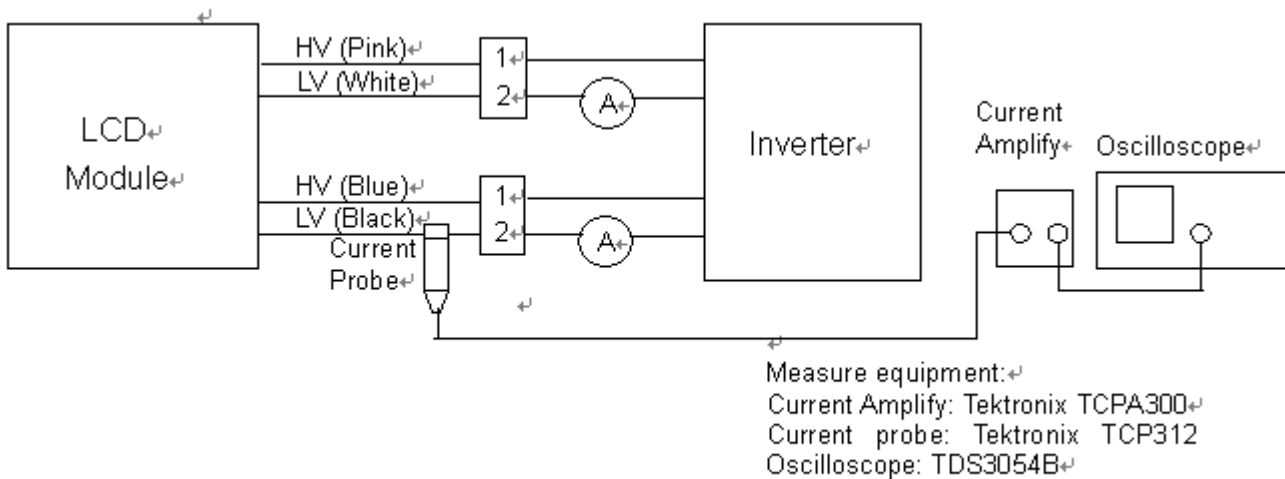

$T_a = 25 \pm 2 \text{ }^\circ\text{C}$

Note (2) The voltage that must be larger than  $V_S$  should be applied to the lamp for more than 1 second after startup. Otherwise, the lamp may not be turned on normally. It is the value output voltage of NF circuit.

Note (3) The lamp frequency may produce interference with horizontal synchronization frequency from the display, which might cause line flow on the display. In order to avoid interference, the lamp frequency should be detached from the horizontal synchronization frequency and its harmonics as far as possible.

Note (4)  $P_L = I_L \times V_L$

Note (5) The lifetime of lamp can be defined as the time in which it continues to operate under the condition  $T_a = 25 \pm 2 \text{ }^\circ\text{C}$  and  $I_L = 8.0 \text{ mA}_{RMS}$  until one of the following events occurs:

(a) When the brightness becomes or lower than 50% of its original value.

(b) When the effective ignition length becomes 80% of its original value.

(The effective ignition length is a scope that luminance is over 70% of that at the center point.)

Note (6) The waveform of the voltage output of inverter must be area-symmetric and the design of the inverter must have specifications for the modularized lamp. The performance of the Backlight, such as lifetime or brightness, is greatly influenced by the characteristics of the DC-AC inverter for the lamp. All the parameters of an inverter should be carefully designed to avoid producing too

much current leakage from high voltage output of the inverter. When designing or ordering the inverter please make sure that a poor lighting caused by the mismatch of the Backlight and the inverter (miss-lighting, flicker, etc.) never occurs. If the above situation is confirmed, the module should be operated in the same manners when it is installed in your instrument.

The output of the inverter must have symmetrical (negative and positive) voltage waveform and symmetrical current waveform. (Unsymmetrical ratio is less than 10%) Please do not use the inverter which has unsymmetrical voltage and unsymmetrical current and spike wave. Lamp frequency may produce interface with horizontal synchronous frequency and as a result this may cause beat on the display. Therefore lamp frequency shall be as away possible from the horizontal synchronous frequency and from its harmonics in order to prevent interference.

Requirements for a system inverter design, which is intended to have a better display performance, a better power efficiency and a more reliable lamp. It shall help increase the lamp lifetime and reduce its leakage current.

- a. The asymmetry rate of the inverter waveform should be 10% below;
- b. The distortion rate of the waveform should be within  $2 \pm 10\%$ ;
- c. The ideal sine wave form shall be symmetric in positive and negative polarities.

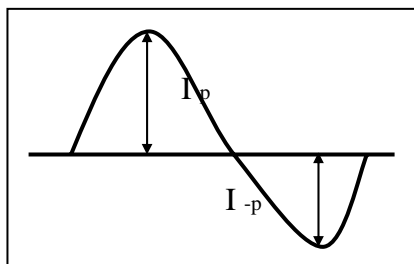

\* Asymmetry rate:

$$| I_p - I_{-p} | / I_{rms} * 100\%$$

\* Distortion rate

$$I_p \text{ (or } I_{-p}) / I_{rms}$$

#### 4. BLOCK DIAGRAM

##### 4.1 TFT LCD MODULE

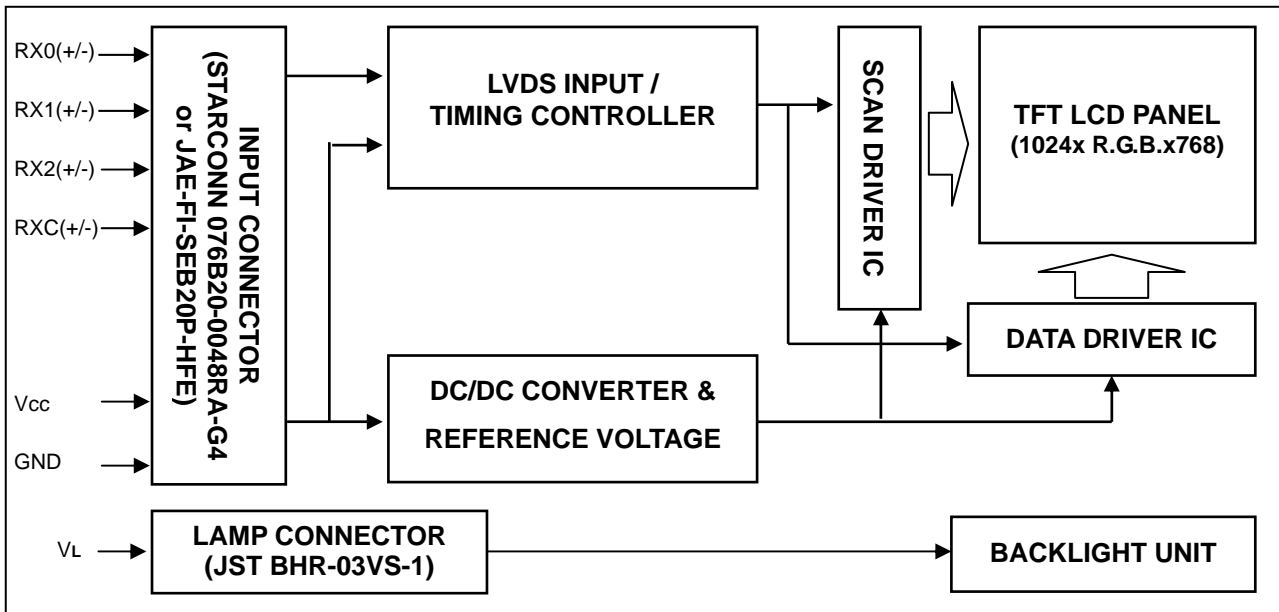

##### 4.2 BACKLIGHT UNIT

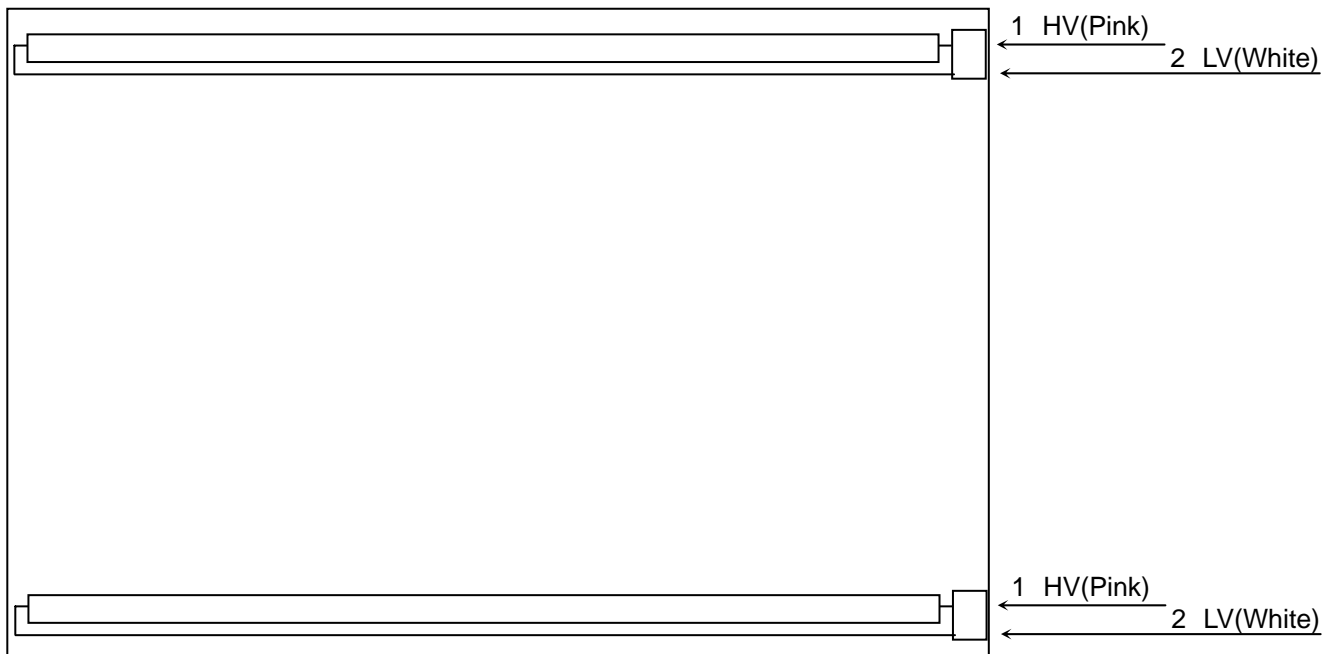

## 5. INPUT TERMINAL PIN ASSIGNMENT

### 5.1 TFT LCD MODULE

Pin	Name	Description	Remark
1	VCC_IN	Power Supply (3.3V )	
2	VCC_IN	Power Supply (3.3 V)	
3	GND	Ground	
4	GND	Ground	
5	RX0-	Differential Data Input, CH0 (Negative )	R0 ~ R5, G0
6	RX0+	Differential Data Input, CH0 ( Positive )	
7	GND	Ground	
8	RX1-	Differential Data Input, CH1 ( Negative )	G1 ~ G5, B0, B1
9	RX1+	Differential Data Input , CH1 ( Positive )	
10	GND	Ground	
11	RX2-	Differential Data Input , CH2 ( Negative )	B2 ~ B5, DE, Hsync, Vsync
12	RX2+	Differential Data Input , CH2 ( Positive )	
13	GND	Ground	
14	CLK-	Differential Clock Input ( Negative )	LVDS Level Clock
15	CLK+	Differential Clock Input ( Positive )	
16	GND	Ground	
17	NA	Non-connection	
18	NA	Non-connection	
19	GND	Ground	
20	GND	Ground	

Note (1) Connector Part No.: STARCONN 076B20-0048RA-G4 or JAE FI-SEB20P-HFE or equivalent.

Note (2) Mating Connector Part No.: JAE-FI-SE20M, FI-S20S or equivalent.

Note (3) The first pixel is odd.

Note (4) Input signal of even and odd clock should be the same timing.

### 5.2 BACKLIGHT UNIT

Pin	Symbol	Description	Remark
1	HV	High Voltage	Pink
2	NA	NA	
3	LV	Low Voltage	White

Note (1) Connector Part No.: JST BHR-03VS-1 or equivalent

Note (2) User's connector Part No.: JST SM03(4.0)B-BHS-1-TB or equivalent

### 5.3 COLOR DATA INPUT ASSIGNMENT

The brightness of each primary color (red, green and blue) is based on the 6-bit gray scale data input for the color. The higher the binary input, the brighter the color. The table below provides the assignment of color versus data input.

Color		Data Signal																	
		Red						Green						Blue					
		R5	R4	R3	R2	R1	R0	G5	G4	G3	G2	G1	G0	B5	B4	B3	B2	B1	B0
Basic Colors	Black	0	0	0	0	0	0	0	0	0	0	0	0	0	0	0	0	0	0
	Red	1	1	1	1	1	1	0	0	0	0	0	0	0	0	0	0	0	0
	Green	0	0	0	0	0	0	1	1	1	1	1	1	0	0	0	0	0	0
	Blue	0	0	0	0	0	0	0	0	0	0	0	0	1	1	1	1	1	1
	Cyan	0	0	0	0	0	0	1	1	1	1	1	1	1	1	1	1	1	1
	Magenta	1	1	1	1	1	1	0	0	0	0	0	0	1	1	1	1	1	1
	Yellow	1	1	1	1	1	1	1	1	1	1	1	1	0	0	0	0	0	0
	White	1	1	1	1	1	1	1	1	1	1	1	1	1	1	1	1	1	1
Gray Scale Of Red	Red(0)/Dark	0	0	0	0	0	0	0	0	0	0	0	0	0	0	0	0	0	0
	Red(1)	0	0	0	0	0	1	0	0	0	0	0	0	0	0	0	0	0	0
	Red(2)	0	0	0	0	1	0	0	0	0	0	0	0	0	0	0	0	0	0
	:	:	:	:	:	:	:	:	:	:	:	:	:	:	:	:	:	:	:
	:	:	:	:	:	:	:	:	:	:	:	:	:	:	:	:	:	:	:
	:	:	:	:	:	:	:	:	:	:	:	:	:	:	:	:	:	:	:
	Red(61)	1	1	1	1	0	1	0	0	0	0	0	0	0	0	0	0	0	0
	Red(62)	1	1	1	1	1	0	0	0	0	0	0	0	0	0	0	0	0	0
Red(63)	1	1	1	1	1	1	0	0	0	0	0	0	0	0	0	0	0	0	
Gray Scale Of Green	Green(0)/Dark	0	0	0	0	0	0	0	0	0	0	0	0	0	0	0	0	0	0
	Green(1)	0	0	0	0	0	0	0	0	0	0	1	0	0	0	0	0	0	0
	Green(2)	0	0	0	0	0	0	0	0	0	1	0	0	0	0	0	0	0	0
	:	:	:	:	:	:	:	:	:	:	:	:	:	:	:	:	:	:	:
	:	:	:	:	:	:	:	:	:	:	:	:	:	:	:	:	:	:	:
	:	:	:	:	:	:	:	:	:	:	:	:	:	:	:	:	:	:	:
	Green(61)	0	0	0	0	0	0	1	1	1	1	0	1	0	0	0	0	0	0
	Green(62)	0	0	0	0	0	0	1	1	1	1	1	0	0	0	0	0	0	0
Green(63)	0	0	0	0	0	0	1	1	1	1	1	1	0	0	0	0	0	0	
Gray Scale Of Blue	Blue(0)/Dark	0	0	0	0	0	0	0	0	0	0	0	0	0	0	0	0	0	0
	Blue(1)	0	0	0	0	0	0	0	0	0	0	0	0	0	0	0	0	0	1
	Blue(2)	0	0	0	0	0	0	0	0	0	0	0	0	0	0	0	0	1	0
	:	:	:	:	:	:	:	:	:	:	:	:	:	:	:	:	:	:	:
	:	:	:	:	:	:	:	:	:	:	:	:	:	:	:	:	:	:	:
	:	:	:	:	:	:	:	:	:	:	:	:	:	:	:	:	:	:	:
	Blue(61)	0	0	0	0	0	0	0	0	0	0	0	1	1	1	1	0	1	0
	Blue(62)	0	0	0	0	0	0	0	0	0	0	0	1	1	1	1	1	1	0
Blue(63)	0	0	0	0	0	0	0	0	0	0	0	1	1	1	1	1	1	1	

Note (1) 0: Low Level Voltage, 1: High Level Voltage

## 6. INTERFACE TIMING

### 6.1 INPUT SIGNAL TIMING SPECIFICATIONS

The input signal timing specifications are shown as the following table and timing diagram.

Signal	Item	Symbol	Min.	Typ.	Max.	Unit	Note
DCLK	Frequency	$F_c$	57.5	64.9	74.4	MHz	
	Period	$T_c$	13.4	15.4	17.3	ns	
Vertical Active Display Term	Frame Rate	$F_r$	56	60	75	Hz	
	Total	$T_v$	774	806	848	$T_h$	$T_v = T_{vd} + T_{vb}$
	Display	$T_{vd}$	768	768	768	$T_h$	
	Blank	$T_{vb}$	$T_v - T_{vd}$	38	$T_v - T_{vd}$	$T_h$	
Horizontal Active Display Term	Total	$T_h$	1240	1344	1464	$T_c$	$T_h = T_{hd} + T_{hb}$
	Display	$T_{hd}$	1024	1024	1024	$T_c$	
	Blank	$T_{hb}$	$T_h - T_{hd}$	320	$T_h - T_{hd}$	$T_c$	

Note : (1) Because this module is operated by DE only mode, Hsync and Vsync input signals should be set to low logic level or ground. Otherwise, this module would operate abnormally.

### INPUT SIGNAL TIMING DIAGRAM

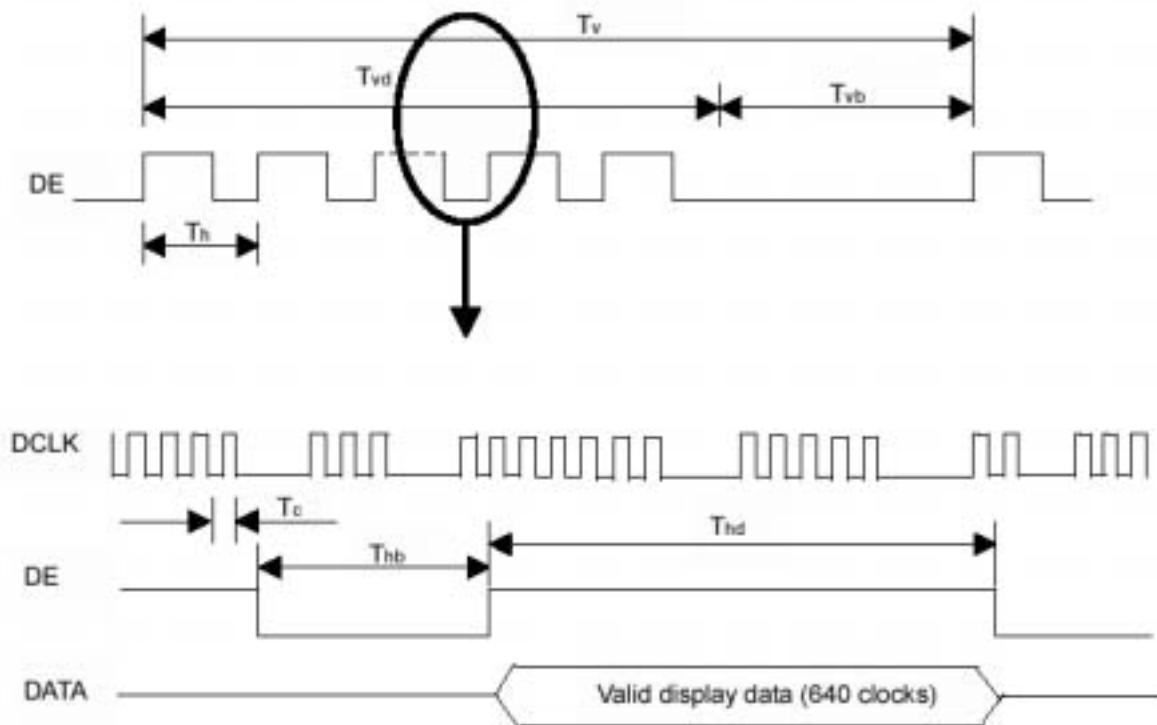

## 6.2 POWER ON/OFF SEQUENCE

To prevent a latch-up or DC operation of LCD module, the power on/off sequence should follow the conditions shown in the following diagram.

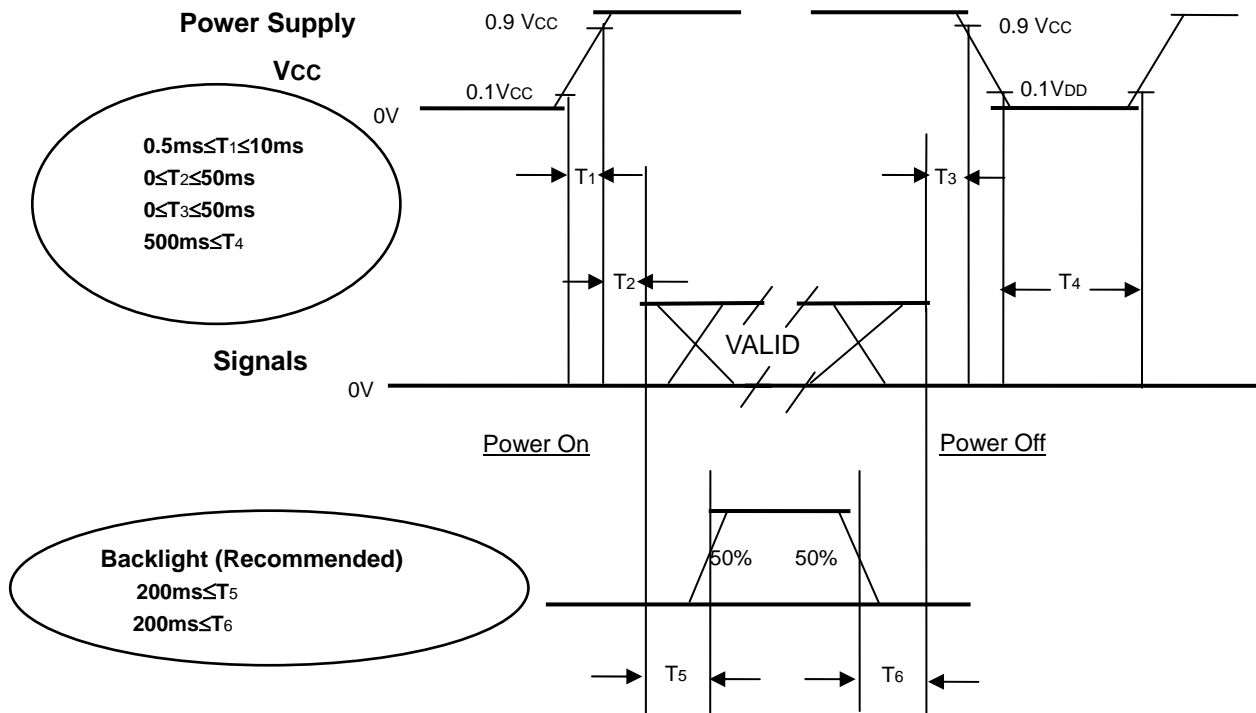

### Power ON/OFF Sequence

Note (1) Please avoid floating state of interface signal at invalid period.

Note (2) When the interface signal is invalid, be sure to pull down the power supply of LCD Vcc to 0 V.

Note (3) The Backlight inverter power must be turned on after the power supply for the logic and the interface signal is valid. The Backlight inverter power must be turned off before the power supply for the logic and the interface signal is invalid.

## 7. OPTICAL CHARACTERISTICS

### 7.1 TEST CONDITIONS

Item	Symbol	Value	Unit
Ambient Temperature	T <sub>a</sub>	25±2	°C
Ambient Humidity	H <sub>a</sub>	50±10	%RH
Supply Voltage	V <sub>CC</sub>	5.0	V
Input Signal	According to typical value in "3. ELECTRICAL CHARACTERISTICS"		
Inverter Current	I <sub>L</sub>	8.0±0.5	mA
Inverter Driving Frequency	F <sub>L</sub>	61±5	KHz
Inverter	Sumida H05-5052		

### 7.2 OPTICAL SPECIFICATIONS

The relative measurement methods of optical characteristics are shown in 7.2. The following items should be measured under the test conditions described in 7.1 and stable environment shown in Note (5).

Item	Symbol	Condition	Min.	Typ.	Max.	Unit	Note			
Color Chromaticity	Red	$\theta_x=0^\circ, \theta_y=0^\circ$ CS-1000	Typ - 0.03	Typ + 0.03			(1), (5)			
								R <sub>x</sub>	0.595	-
	R <sub>y</sub>							0.339	-	
	Green							G <sub>x</sub>	0.317	-
								G <sub>y</sub>	0.531	-
	Blue							B <sub>x</sub>	0.152	-
								B <sub>y</sub>	0.123	-
	White							W <sub>x</sub>	0.308	-
W <sub>y</sub>		0.318	-							
Center Luminance of White	L <sub>C</sub>		380	500	-	-	(4), (5)			
Contrast Ratio	CR		500	700	-	-	(2), (5)			
Response Time	T <sub>R</sub>	$\theta_x=0^\circ, \theta_y=0^\circ$					(3)			
	T <sub>F</sub>							-	6	11
White Variation	$\delta W$	$\theta_x=0^\circ, \theta_y=0^\circ$	-	1.25	1.4	-	(5), (6)			
Viewing Angle	Horizontal	CR≥10					Deg.			
								$\theta_{x+}$	70	80
	$\theta_{x-}$							70	80	-
	Vertical							$\theta_{y+}$	70	80
$\theta_{y-}$		70	80	-						
Contrast Ratio in daylight	CR	Sun lamp	40	60	-	-	(7)			



Note (1) Definition of Viewing Angle ( $\theta_x, \theta_y$ ):

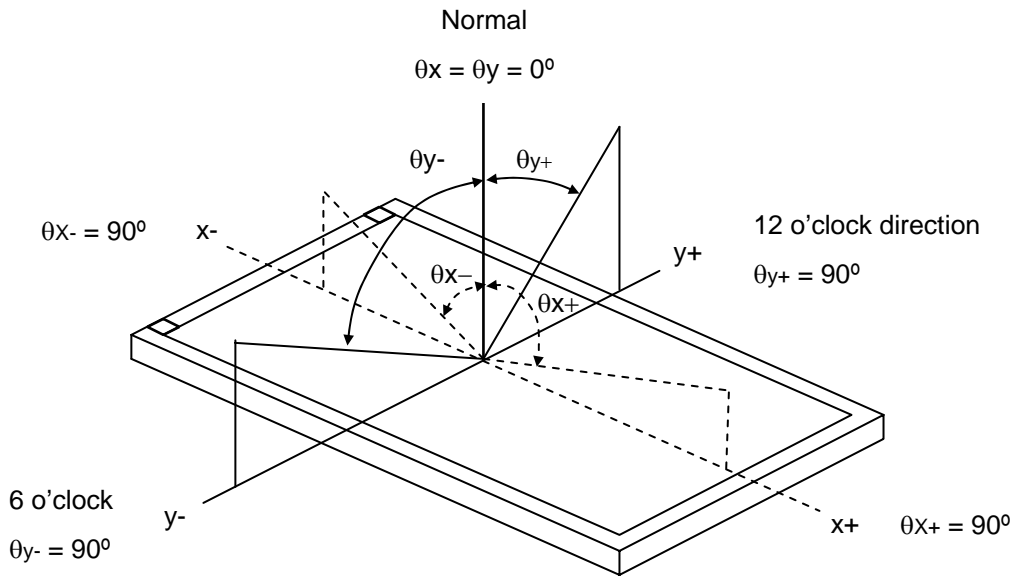

Note (2) Definition of Contrast Ratio (CR):

The contrast ratio can be calculated by the following expression.

$$\text{Contrast Ratio (CR)} = L_{63} / L_0$$

L63: Luminance of gray level 63

L 0: Luminance of gray level 0

$$\text{CR} = \text{CR} (5)$$

CR (X) is corresponding to the Contrast Ratio of the point X at Figure in Note (6).

Note (3) Definition of Response Time ( $T_R, T_F$ ) and measurement method:

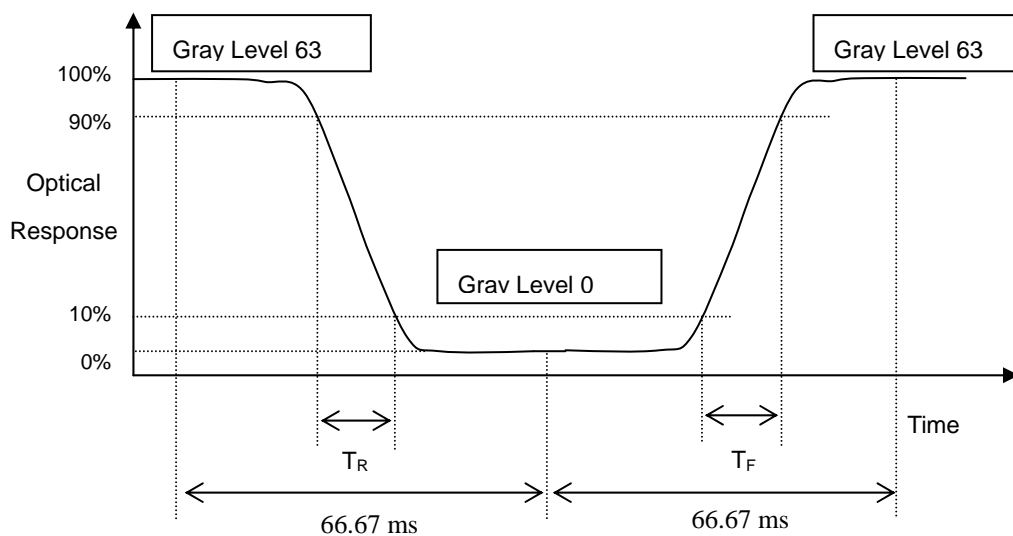

Note (4) Definition of Luminance of White ( $L_C$ ):

Measure the luminance of gray level 63 at center point

$$L_C = L(5)$$

$L(x)$  is corresponding to the luminance of the point X at Figure in Note (6).

Note (5) Measurement Setup:

The LCD module should be stabilized at given temperature for 20 minutes to avoid abrupt temperature change during measuring. In order to stabilize the luminance, the measurement should be executed after lighting Backlight for 20 minutes in a windless room.

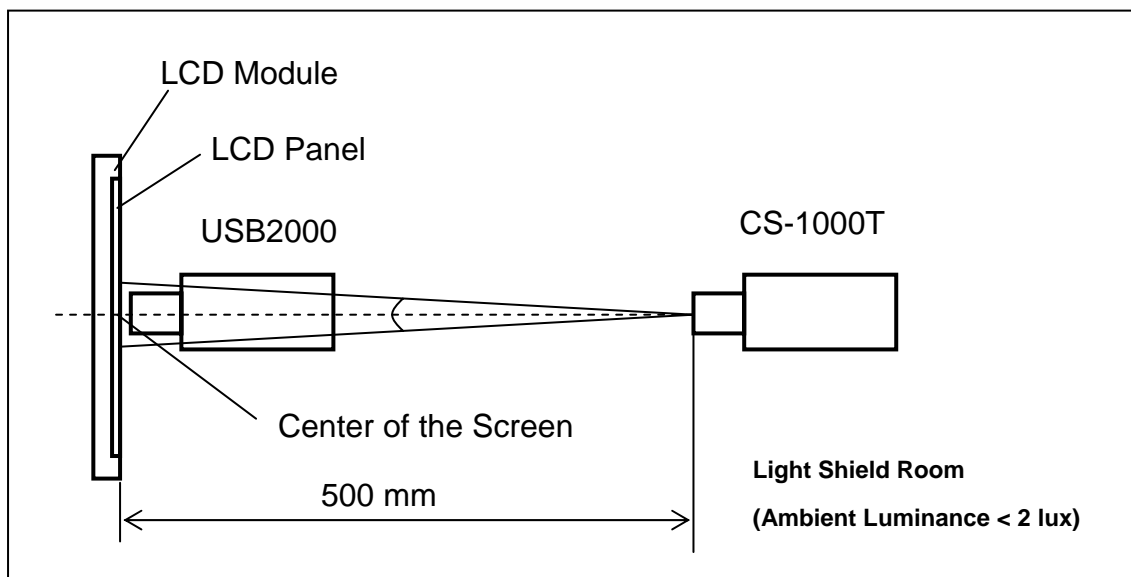

Note (6) Definition of White Variation ( $\delta W$ ):

Measure the luminance of gray level 63 at 5 points

$$\delta W = \frac{\text{Maximum [L (1), L (2), L (3), L (4), L (5)]}}{\text{Minimum [L (1), L (2), L (3), L (4), L (5)]}}$$

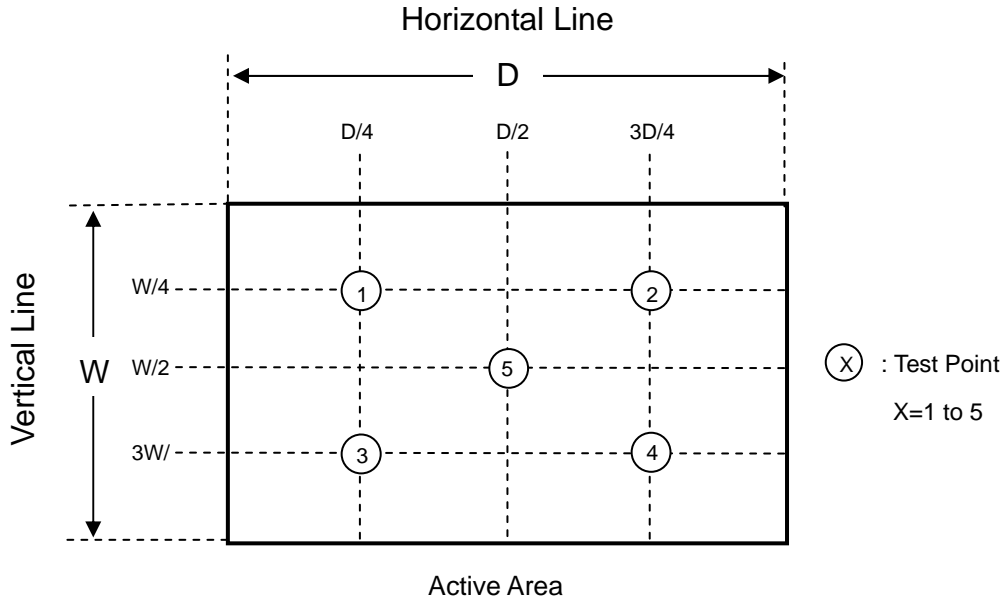

Note (7) Contrast Ratio in daylight:

Measuring method:

Sun lamp: 10000 Lux

Contrast Ratio in daylight = Luminance of white screen / Luminance of black screen

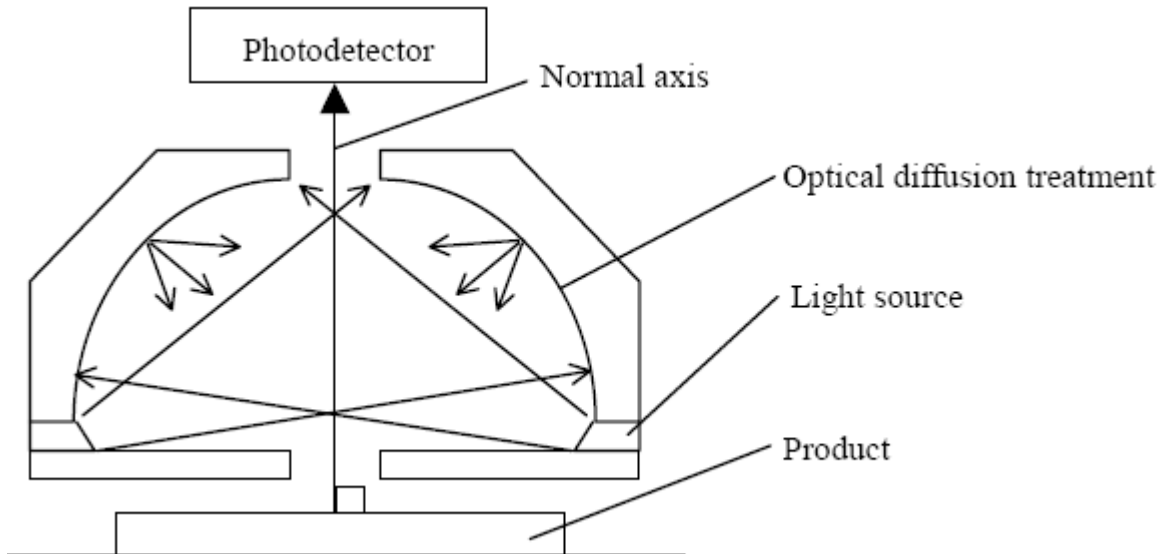

## 8. PACKAGING

### 8.1 PACKING SPECIFICATIONS

- (1) 15pcs LCD modules / 1 Box
- (2) Box dimensions: 461 (L) X 362 (W) X 314 (H) mm
- (3) Weight: approximately 11.15Kg (15 modules per box)

### 8.2 PACKING METHOD

- (1) Carton Packing should have no failure in the following reliability test items.

Test Item	Test Conditions	Note
Vibration	ISTA STANDARD Random, Frequency Range: 2 – 200 Hz Top & Bottom: 30 minutes (+Z), 10 min (-Z), Right & Left: 10 minutes (X) Back & Forth 10 minutes (Y)	Non Operation
Dropping Test	1 Angle, 3 Edge, 6 Face, 61 cm	Non Operation

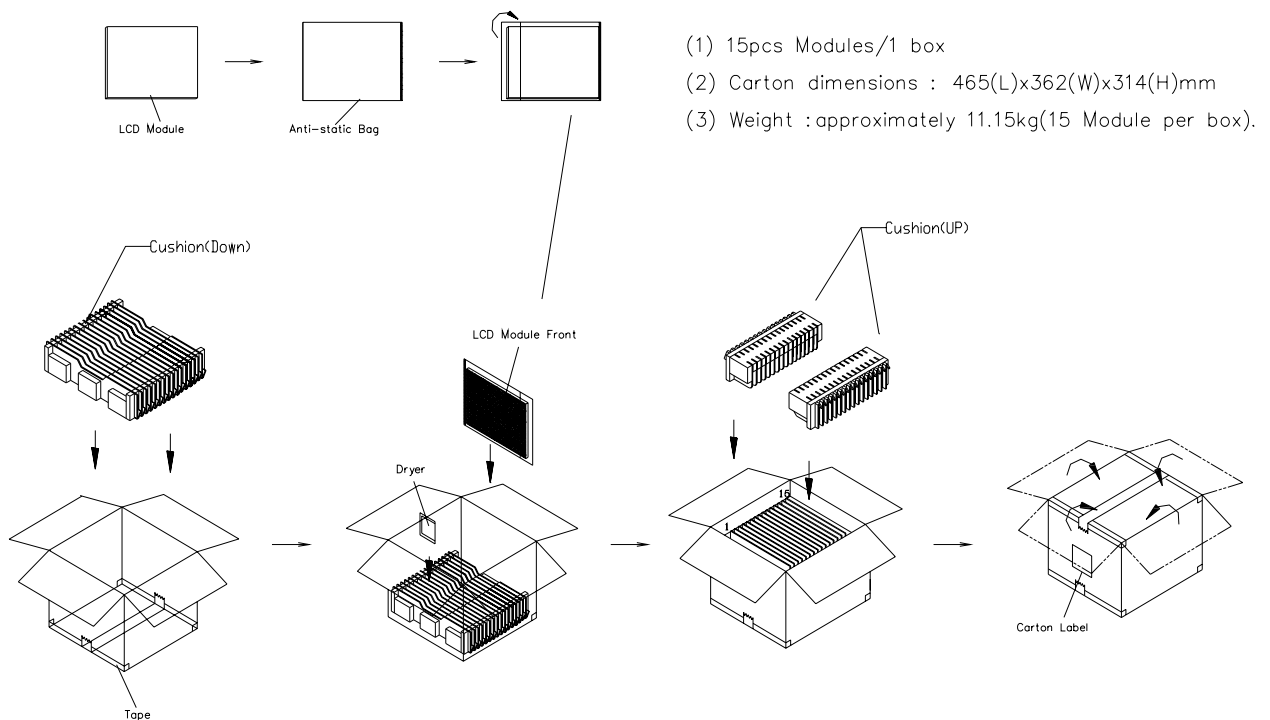

**Figure. 8-1 Packing method**

Sea Transportation

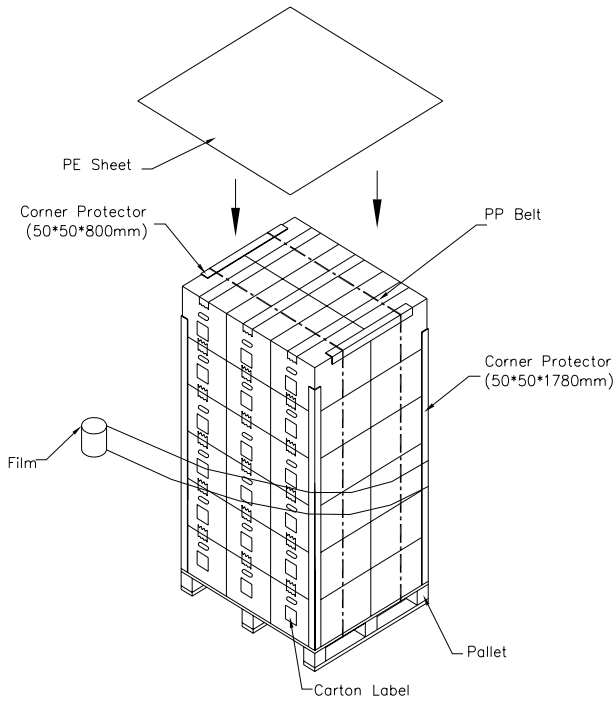

Air Transportation

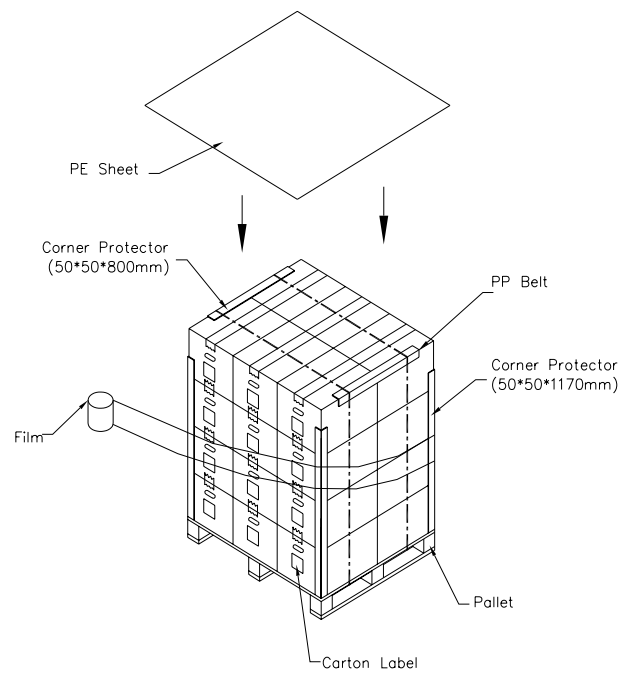

Figure. 8-2 Packing method

## 9. DEFINITION OF LABELS

### 9.1 CMO MODULE LABEL

The barcode nameplate is pasted on each module as illustration, and its definitions are as following explanation.



- (a) Model Name: G121X1-L02
- (b) Revision: Rev. XX, for example: A0, A1... B1, B2... or C1, C2...etc.
- (c) CMO barcode definition:

Serial ID: XX-XX-X-XX-YMD-L-NNNN

Code	Meaning	Description
XX	CMO internal use	-
XX	Revision	Cover all the change
X	CMO internal use	-
YMD	Year, month, day	Year: 2001=1, 2002=2, 2003=3, 2004=4... Month: 1~12=1, 2, 3, ~, 9, A, B, C Day: 1~31=1, 2, 3, ~, 9, A, B, C, ~, W, X, Y, exclude I, O, U.
L	Product line #	Line 1=1, Line 2=2, Line 3=3, ...etc.
NNNN	Serial number	Manufacturing sequence of product

## 10. PRECAUTIONS

### 10.1 ASSEMBLY AND HANDLING PRECAUTIONS

- (1) Do not apply rough force such as bending or twisting to the module during assembly.
- (2) To assemble or install module into user's system can be only in clean working areas. The dust and oil may cause electrical short or worsen the polarizer.
- (3) It's not permitted to have pressure or impulse on the module because the LCD panel and Backlight will be damaged.
- (4) Always follow the correct power sequence when LCD module is connecting and operating. This can prevent damage to the CMOS LSI chips during latch-up.
- (5) Do not pull the I/F connector in or out while the module is operating.
- (6) Do not disassemble the module.
- (7) Use a soft dry cloth without chemicals for cleaning, because the surface of polarizer is very soft and easily scratched.
- (8) It is dangerous that moisture come into or contacted the LCD module, because moisture may damage LCD module when it is operating.
- (9) High temperature or humidity may reduce the performance of module. Please store LCD module within the specified storage conditions.
- (10) When ambient temperature is lower than 10°C may reduce the display quality. For example, the response time will become slowly, and the starting voltage of CCFL will be higher than room temperature.
- (11) Do not keep same pattern in a long period of time. It may cause image sticking on LCD.

### 10.2 SAFETY PRECAUTIONS

- (1) The startup voltage of Backlight is approximately 1000 Volts. It may cause electrical shock while assembling with inverter. Do not disassemble the module or insert anything into the Backlight unit.
- (2) If the liquid crystal material leaks from the panel, it should be kept away from the eyes or mouth. In case of contact with hands, skin or clothes, it has to be washed away thoroughly with soap.
- (3) After the module's end of life, it is not harmful in case of normal operation and storage.

NOTES:  
 1. UNSPECIFIED TOLERANCE:  $\pm 0.5\text{mm}$ .  
 2. \* MARKS THE DESIGN CRITICAL DIMENSION.  
 3.  $\text{\textcircled{P}}$  MARKS THE PROCESS CRITICAL DIMENSION.  
 4. I/F CONNECTOR SPEC: JAE FI-SEB20P-HFE or Starcomm 076B20-0048RA-G4

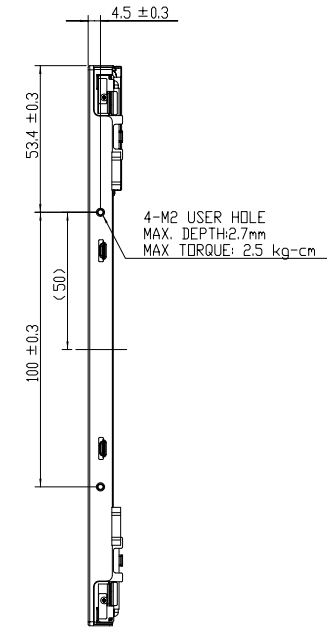
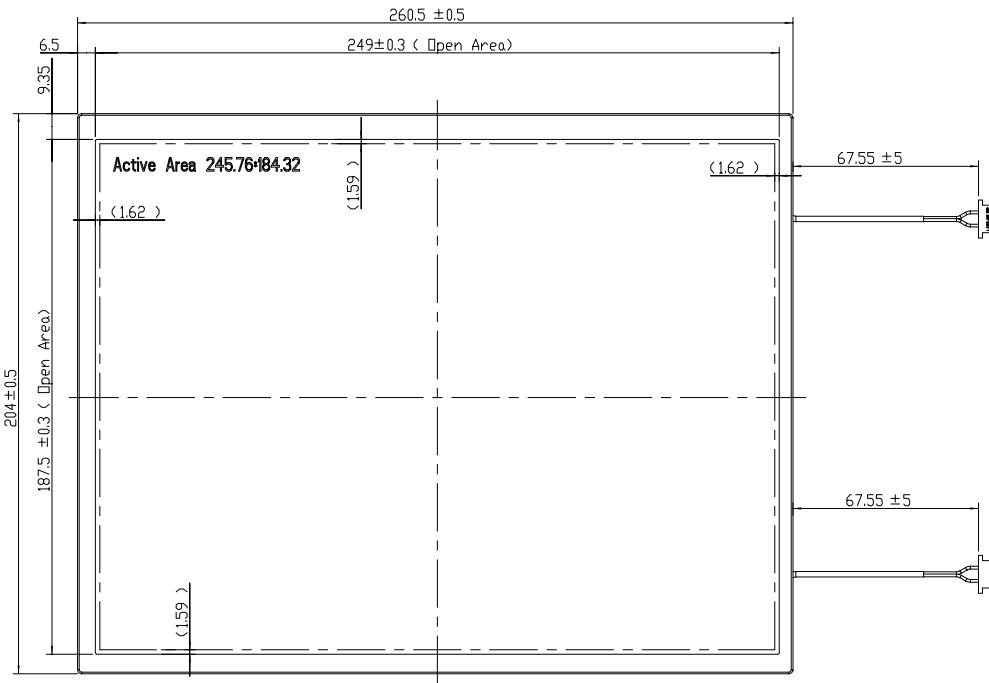
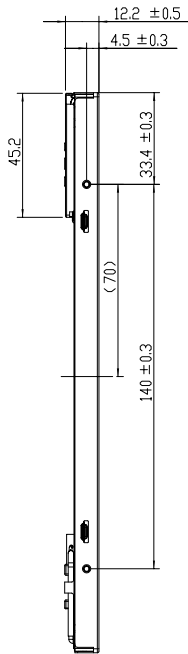

Mark	Description	Date	Changed_By	Approved_By	ECN No.	Remark

TITLE: ASSY_MODULE_G121X1-L02		PD REV: 1A
Approved: TIGER_CHANG		0D REV: 118*
Checking: ALAN_LEE	Drawing No: G1212404A	
Drawer: ANONA_PAN	Part No: TBD	
Designer: ANONA_PAN	Date: 24-Jul-2008	Scale: 1:1
		Unit: mm
		ALL RIGHTS RESERVED, COPYING FORBIDDEN.



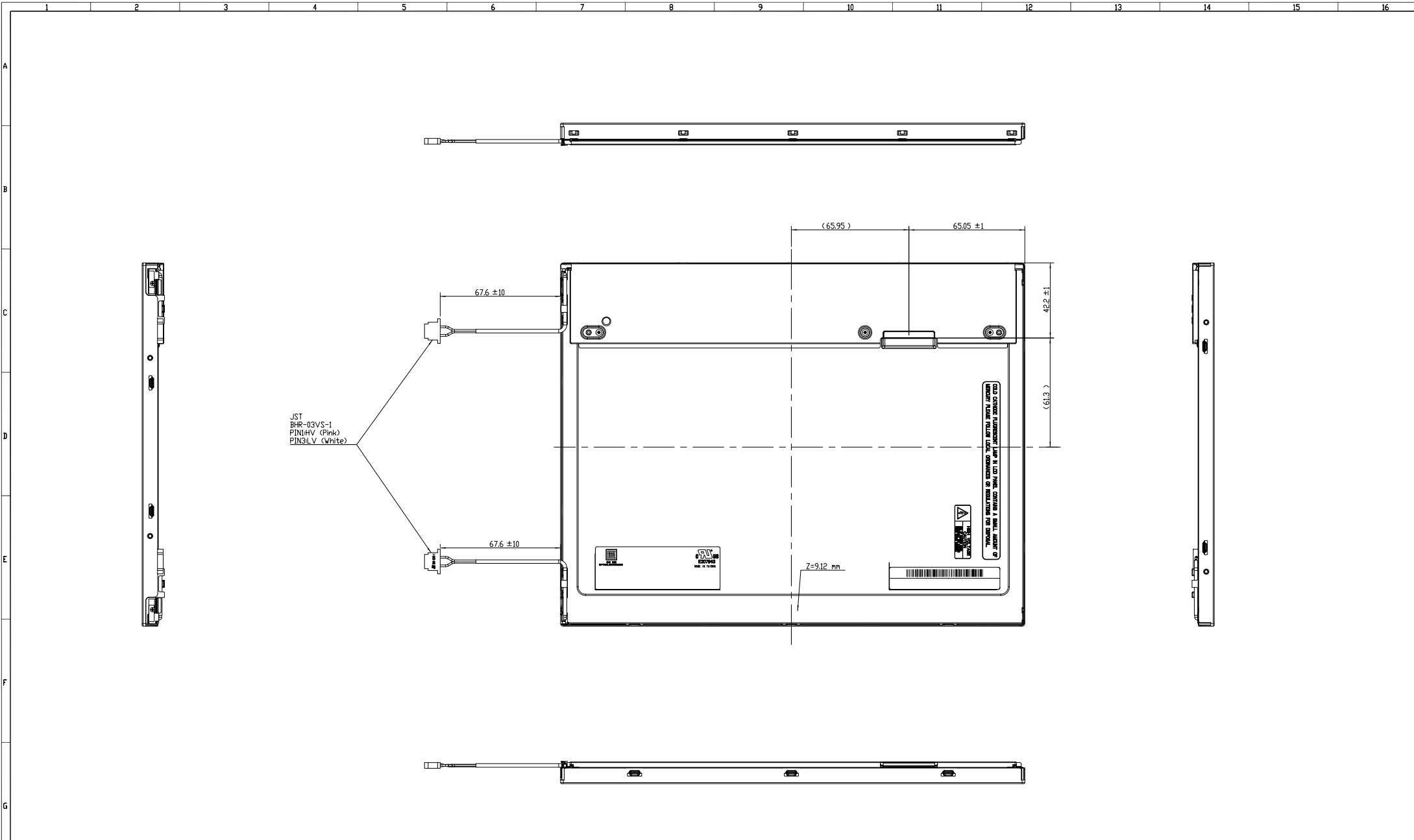

NOTES:  
 1. UNSPECIFIED TOLERANCE: ±0.5mm.  
 2. \* MARKS THE DESIGN CRITICAL DIMENSION.  
 3. © MARKS THE PROCESS CRITICAL DIMENSION.  
 4. I/F CONNECTOR SPEC: JAE F1-SEB20P-HFE or Starconn 076B20-0048RA-G4

Mark	Description	Date	Changed_By	Approved_By	ECN No.	Remark

TITLE: ASSY_MODULE_G121X1-L02		PD REV: 1A	
Approved: TIGER_CHANG		Drawing No: G12124104A	
Checked: ALAN_LEE		Part No: TBD	
Drawer: ANONA_PAN	Material: TBD	Sheet: 2 / 2	Alt: AL
Designer: ANONA_PAN	Date: 24-Jul-2008	Scale: 1:1	Unit: mm
		ALL RIGHTS RESERVED, COPYING FORBIDDEN.	