

TFT LCD Approval Specification

MODEL NO.: G104V1-T03

Customer: _____

Approved by: _____

Note:

核准時間	部門	審核	角色	投票
2010-06-08 19:10:35	APPL 產品管理處	張喻翔 (yhchang)	Director	Accept

- CONTENTS -

REVISION HISTORY	-----	3
1. GENERAL DESCRIPTION	-----	4
1.1 OVERVIEW		
1.2 FEATURES		
1.3 APPLICATION		
1.4 GENERAL SPECIFICATIONS		
1.5 MECHANICAL SPECIFICATIONS		
2. ABSOLUTE MAXIMUM RATINGS	-----	6
2.1 ABSOLUTE RATINGS OF ENVIRONMENT		
2.2 ELECTRICAL ABSOLUTE RATINGS		
2.2.1 TFT LCD MODULE		
2.2.2 LED CONVERTER		
3. ELECTRICAL CHARACTERISTICS	-----	7
3.1 TFT LCD MODULE		
3.2 LED CONVERTER		
4. BLOCK DIAGRAM	-----	11
4.1 TFT LCD MODULE		
5. INPUT TERMINAL PIN ASSIGNMENT	-----	12
5.1 TFT LCD MODULE		
5.2 BACKLIGHT UNIT		
5.3 COLOR DATA INPUT ASSIGNMENT		
6. INTERFACE TIMING	-----	15
6.1 INPUT SIGNAL TIMING SPECIFICATIONS		
6.2 POWER ON/OFF SEQUENCE		
6.3 SCANNING DIRECTION		
7. OPTICAL CHARACTERISTICS	-----	18
7.1 TEST CONDITIONS		
7.2 OPTICAL SPECIFICATIONS		
8. RELIABILITY TEST CRITERIA	-----	21
9. PACKAGING	-----	22
9.1 PACKING SPECIFICATIONS		
9.2 PACKING METHOD		
10. DEFINITION OF LABELS	-----	24
10.1 CMO MODULE LABEL		
11. PRECAUTIONS	-----	25
11.1 ASSEMBLY AND HANDLING PRECAUTIONS		
11.2 SAFETY PRECAUTIONS		
12. MECHANICAL CHARACTERISTICS	-----	26

REVISION HISTORY

Version	Date	Section	Description
0. 0	July 29,2009	All	G104V1-T03 Tentative Spec was first issued.
1. 0	Mar 12,2010		G104V1-T03 Preliminary Spec was first issued.
		1.4	Add the Module Power Consumption value.
		1.5	Add note(1) with module depth typical value 7.8mm without TTL connector and 9.34 mm with TTL connector.
		2.1	Add plot of temperature v.s relative humidity.
		3.1	Add Max Power Supply Current under white/black pattern. Add Power Consumption valueof TFT-LCD
		3.2	Modify Converter Power Supply Current to 0.6A. Modify Converter Power Consumption to 7.2W.
		4.1	Remove HS/VS symbol and add converter ADJ/EN symbol.
		5.1	Pin3/4 change to NC.
		6.1	Add Horizontal/Vertical Active Display Term parameter. Note(1):remove Hsync/Vsync description.
		6.2	Modify power on/off sequence and delay time request(T6/T7/T10).
		7.2	Modify optical specification value. Modify note(4) : gray level L255 to L63.
		9.1	Modify Q'ty per carton and weight.
		9.2	Modify Q'ty per carton and weight.
		10.1	Modify Manufactured Date : Year:1~9, for 2010~2019
		12	Update module drawing to Ver1.0
2. 0	May 17,2010		G104V1-T03 Approval Spec was first issued.
		1.4	Modify the module power consumption
		1.5	Modify module thickness and weight
		3.1	Modify Power supply current of white/black pattern and power consumption
		3.2	Modify LED converter power supply current and power consumption

1. GENERAL DESCRIPTION

1.1 OVERVIEW

The G104V1-T03 model is a 10.4" TFT-LCD module with white LED Backlight Unit and a 31-pin and 1ch TTL interface. This module supports 640 x 480 VGA mode and display 262,144 colors. The converter for the LED Backlight Unit is built in.

1.2 FEATURES

- Wide viewing angle
- High contrast ratio
- VGA (640 x 480 pixels) resolution
- Wide operating temperature
- DE (Data Enable) mode
- CMOS/TTL (Transistor-Transistor Logic) interface
- Reversible-scan direction
- RoHS Compliance
- LED Light Bar Replaceable

1.3 APPLICATION

- TFT LCD Monitor
- Industrial Application
- Amusement

1.4 GENERAL SPECIFICATIONS

Item	Specification	Unit	Note
Diagonal Size	10.4	inch	(1)
Active Area	211.2(H) x 158.4(V)	mm	
Bezel Opening Area	215.4(H) x 161.8(V)	mm	
Driver Element	a-si TFT active matrix	-	-
Pixel Number	640 x R.G.B. x 480	pixel	-
Pixel Pitch	0.33(H) x 0.33(V)	mm	-
Pixel Arrangement	RGB vertical stripe	-	-
Display Colors	262,144	color	-
Transmissive Mode	Normally black	-	-
Surface Treatment	Hard coating (3H), Anti-glare (Haze 25%)	-	-
Module Power Consumption	8.94	W	Typ.

1.5 MECHANICAL SPECIFICATIONS

Item	Min.	Typ.	Max.	Unit	Note	
Module Size	Horizontal (H)	225	225.5	226	mm	(1)
	Vertical (V)	175.8	176.3	176.8	mm	
	Depth (D)	8.84(7.31)	9.34(7.81)	9.84(8.31)	mm	
Weight	345	395	445	g	-	(2)
I/F connector mounting position	The mounting inclination of the connector makes the screen center within $\pm 0.5\text{mm}$ as the horizontal.			-	(2)	

Note (1) Please refer to the attached drawings for more information of front and back outline dimensions.

Module depth 7.8mm does not include TTL connector, with TTL connector is 9.34mm (typical).

(2) Connector mounting position

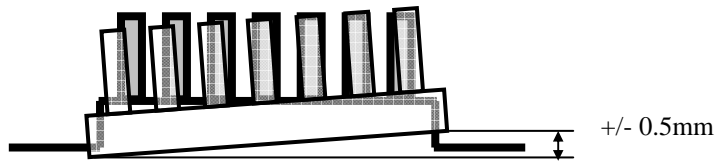

2. ABSOLUTE MAXIMUM RATINGS

2.1 ABSOLUTE RATINGS OF ENVIRONMENT

Item	Symbol	Value		Unit	Note
		Min.	Max.		
Operating Ambient Temperature	T _{OP}	-30	+80	°C	
Storage Temperature	T _{ST}	-30	+80	°C	

Note (1) 90 %RH Max. (Ta ≤ 40 °C).

(2) Wet-bulb temperature should be 39 °C Max. (Ta > 40 °C).

(3) No condensation.

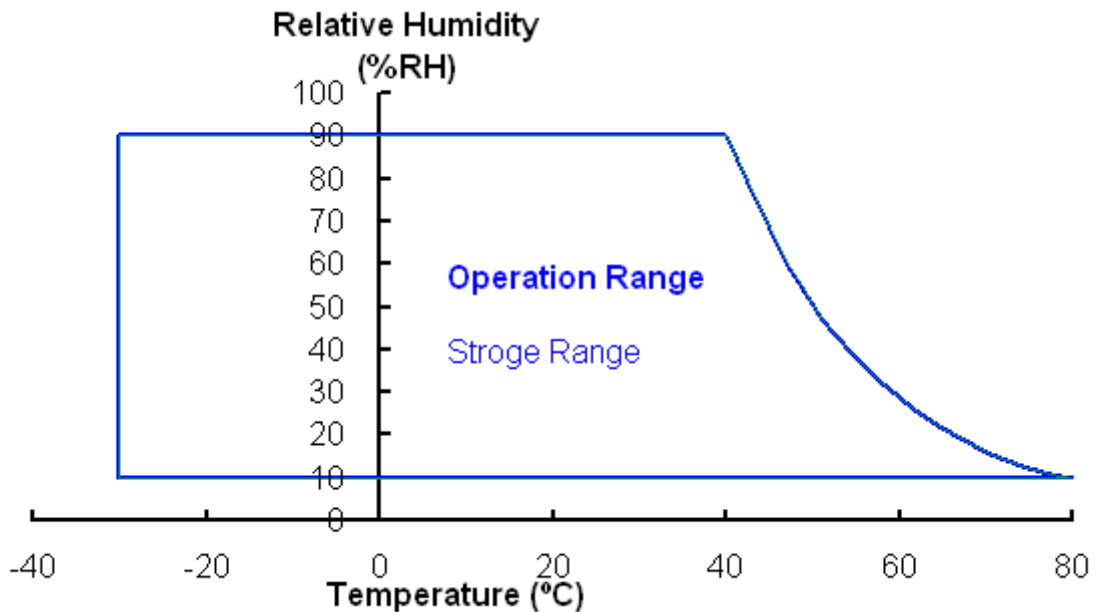

2.2 ELECTRICAL ABSOLUTE RATINGS

2.2.1 TFT LCD MODULE

Item	Symbol	Value		Unit	Note
		Min.	Max.		
Power Supply Voltage	VCC	-0.3	7	V	(1)

2.2.2 LED CONVERTER

Item	Symbol	Value		Unit	Note
		Min.	Max.		
Converter Voltage	V _i	-0.3	18	V	(1), (2)
Enable Voltage	EN	---	5.5	V	
Backlight Adjust	ADJ	---	5.5	V	

Note (1) Permanent damage to the device may occur if maximum values are exceeded. Function operation should be restricted to the conditions described under Normal Operating Conditions.

Note (2) Specified values are for LED (Refer to 3.2 for further information).

3. ELECTRICAL CHARACTERISTICS

3.1 TFT LCD MODULE

Ta = 25 ± 2 °C

Parameter	Symbol	Value			Unit	Note	
		Min.	Typ.	Max.			
Power Supply Voltage	VCC	3.0	3.3	3.6	V	at VCC=3.3V	
		4.75	5.0	5.25	V	at VCC=5.0V	
Power Supply Current	White	---	450	490	540	mA	(3)a, at VCC=3.3V, 60Hz
			360	390	440	mA	(3)a, at VCC=5.0V, 60Hz
	Black	---	420	470	520	mA	(3)b, at VCC=3.3V, 60Hz
			330	380	430	mA	(3)b, at VCC=5.0V, 60Hz
Power Consumption	PL	---	1.617	---	W	VCC=3.3V, 60Hz	
Logic input voltage	V _{IH}	0.7V _{CC}	-	V _{CC}	V		
	V _{IL}	0	-	0.3V _{CC}	V		

Note (1) The module is recommended to operate within specification ranges listed above for normal function.

Note (2) Measurement Conditions:

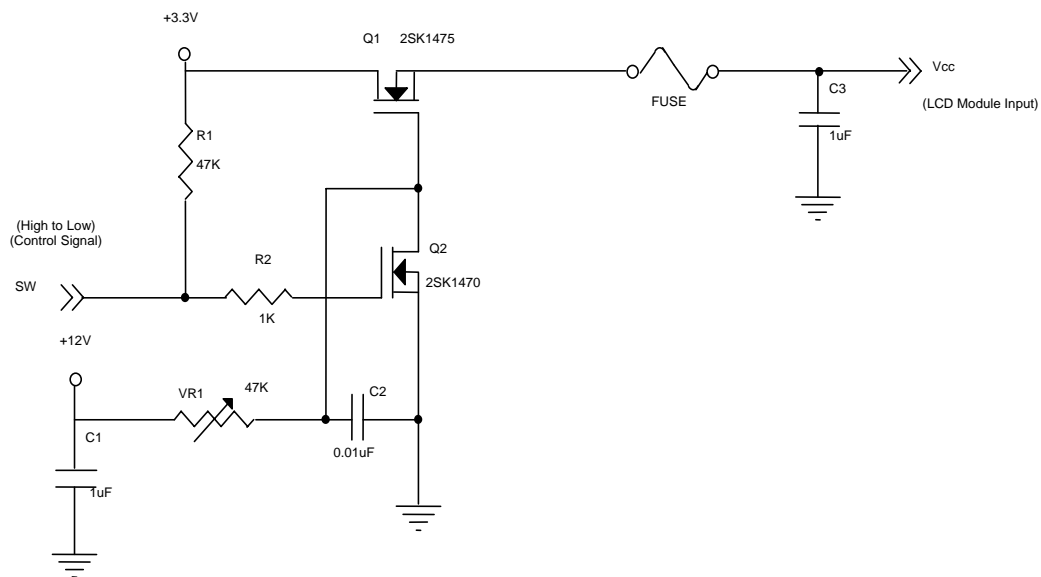

Vcc rising time is 470µs

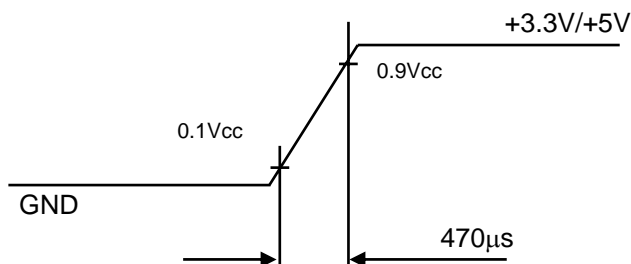

Note (3) The specified power supply current is under the conditions at $T_a = 25 \pm 2 \text{ }^\circ\text{C}$, $f_v = 60 \text{ Hz}$, whereas a power dissipation check pattern below is displayed.

a. White Pattern



Active Area

b. Black Pattern

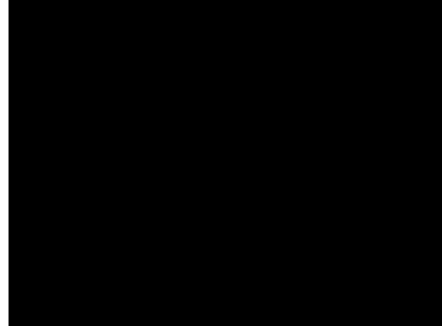

Active Area

3.2 LED CONVERTER

 $T_a = 25 \pm 2 \text{ }^\circ\text{C}$

Parameter	Symbol	Value			Unit	Note
		Min.	Typ.	Max.		
Converter Power Supply Voltage	V_i	10.8	12.0	12.6	V	(Duty 100%)
Converter Power Supply Current	I_i	---	0.61	---	A	(1) $V_i = 12\text{V}$ (Duty 100%)
Converter Power Consumption	P_i	---	7.32	---		(1) $V_i = 12\text{V}$ (Duty 100%)
EN Control Level	Backlight on	2.0	3.3	5.0	V	
	Backlight off	0	---	0.8	V	
PWM Control Level	PWM High Level	2.0	3.3	5.0	V	
	PWM Low Level	0	---	0.8	V	
PWM Control Duty Ratio		20		100	%	
PWM Control Frequency	f_{PWM}	190	200	210	Hz	
LED Life Time	L_L	50,000			Hrs	(2)

Note (1) LED current is measured by utilizing a high frequency current meter as shown below:

Note (2) The lifetime of LED is defined as the time when it continues to operate under the conditions at $T_a = 25 \pm 2$ and $I_{\text{LED}} = 80\text{mA}_{\text{DC}}$ (LED forward current) until the brightness becomes 50% of its original value. And minimum LED lifetime is estimated and provided by Nichia in Japan.

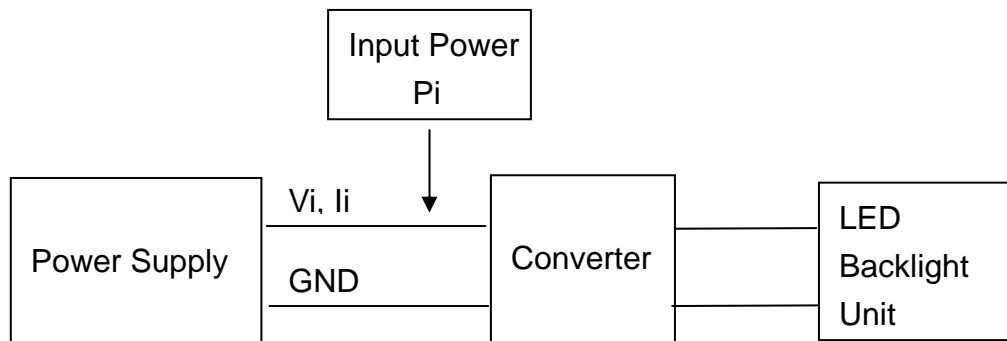

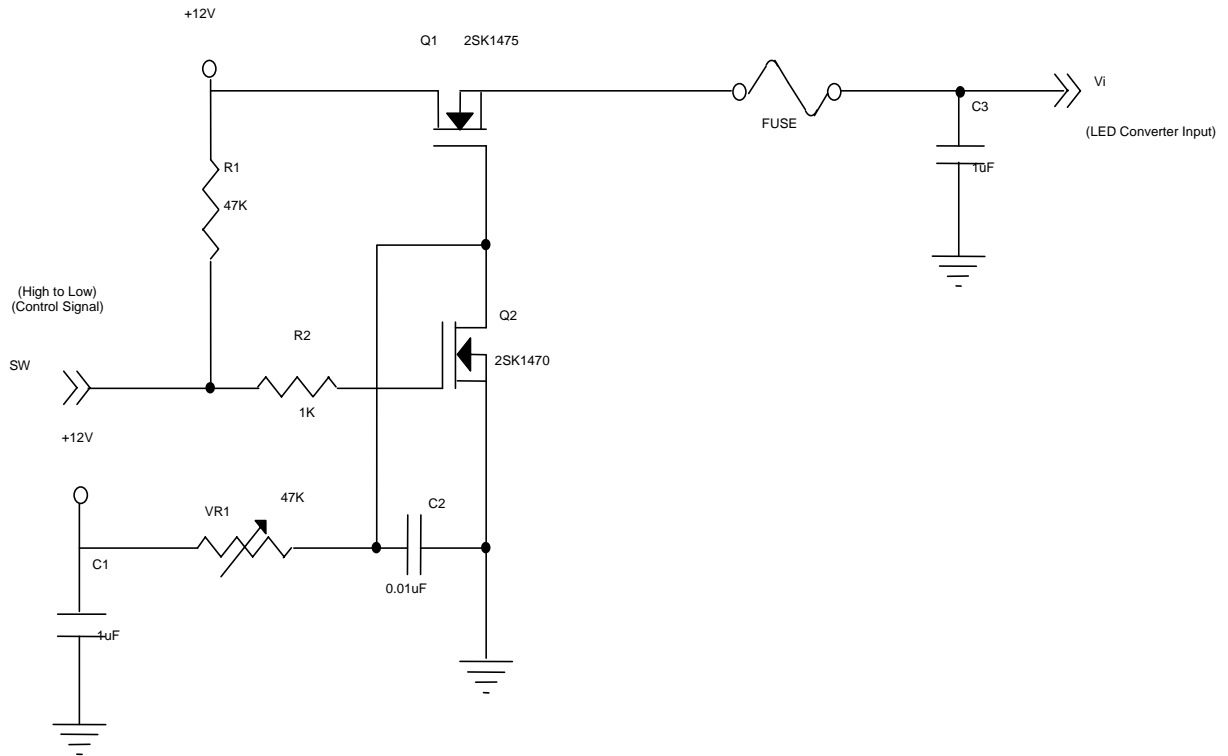

Vi rising time is 470us

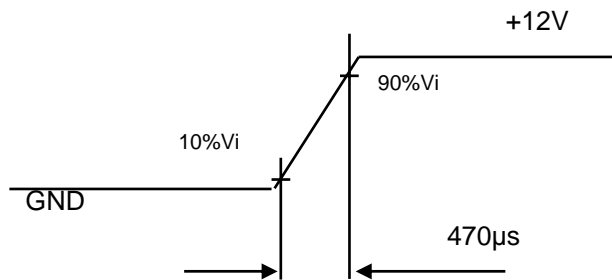

4. BLOCK DIAGRAM

4.1 TFT LCD MODULE

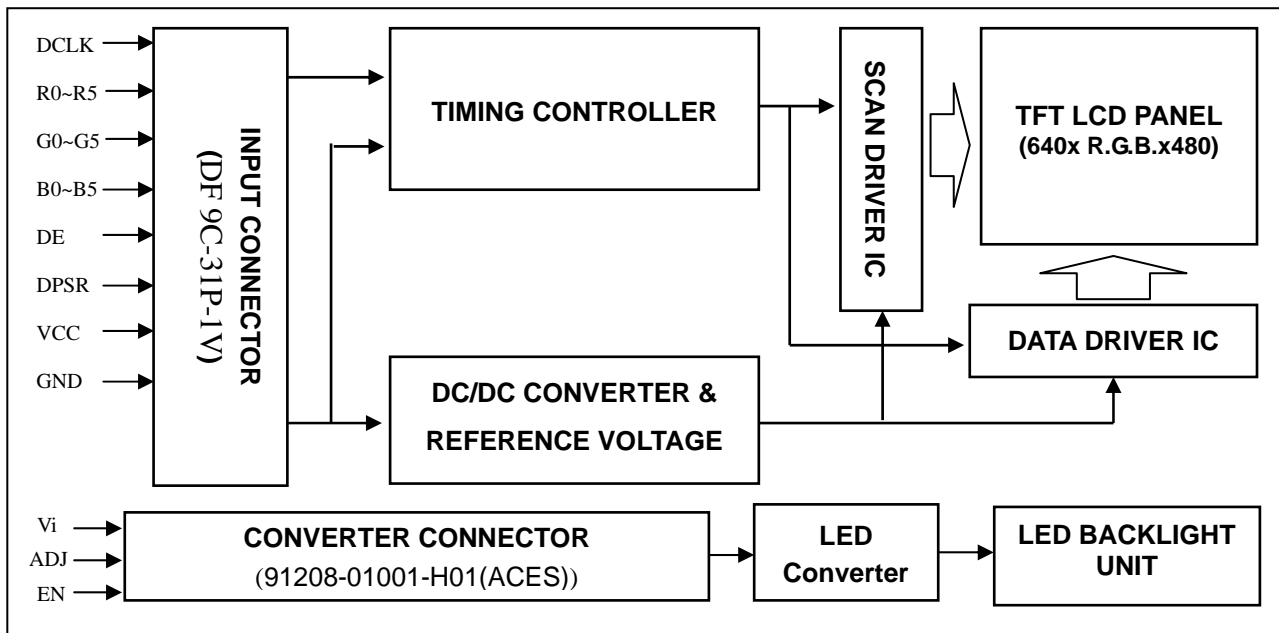

5. INPUT TERMINAL PIN ASSIGNMENT

5.1 TFT LCD MODULE

Pin	Name	Description
1	GND	Ground
2	DCLK	Dot clock
3	N.C.	N.C.
4	N.C.	N.C.
5	GND	Ground
6	R0	Red data (LSB)
7	R1	Red data
8	R2	Red data
9	R3	Red data
10	R4	Red data
11	R5	Red data (MSB)
12	GND	Ground
13	G0	Green data (LSB)
14	G1	Green data
15	G2	Green data
16	G3	Green data
17	G4	Green data
18	G5	Green data (MSB)
19	GND	Ground
20	B0	Blue data (LSB)
21	B1	Blue data
22	B2	Blue data
23	B3	Blue data
24	B4	Blue data
25	B5	Blue data (MSB)
26	GND	Ground
27	DE	Data enable signal
28	VCC	Power supply
29	VCC	Power supply
30	N.C.	Reserved, please keep it floating.
31	DPSR	Selection of scan direction

Note (1) Connector Part No.: DF 9C-31P-1V or equivalent.

5.2 BACKLIGHT UNIT(Converter connector pin)

Pin	Symbol	Description	Remark
1	V_i	Converter input voltage	12V
2	V_{GND}	Converter ground	Ground
3	EN	Enable pin	
4	ADJ	Backlight Adjust	PWM Dimming
5	NC	Not Connect	

Note (1) Connector Part No.: 3823K-F05N-00L (Entry) or equivalent

Note (2) User's connector Part No.: H208K-P05N-02B (Entry) or equivalent

5.3 COLOR DATA INPUT ASSIGNMENT

The brightness of each primary color (red, green and blue) is based on the 6-bit gray scale data input for the color. The higher the binary input, the brighter the color. The table below provides the assignment of color versus data input.

Color		Data Signal																	
		Red						Green						Blue					
		R5	R4	R3	R2	R1	R0	G5	G4	G3	G2	G1	G0	B5	B4	B3	B2	B1	B0
Basic Colors	Black	0	0	0	0	0	0	0	0	0	0	0	0	0	0	0	0	0	0
	Red	1	1	1	1	1	1	0	0	0	0	0	0	0	0	0	0	0	0
	Green	0	0	0	0	0	0	1	1	1	1	1	1	0	0	0	0	0	0
	Blue	0	0	0	0	0	0	0	0	0	0	0	0	1	1	1	1	1	1
	Cyan	0	0	0	0	0	0	1	1	1	1	1	1	1	1	1	1	1	1
	Magenta	1	1	1	1	1	1	0	0	0	0	0	0	1	1	1	1	1	1
	Yellow	1	1	1	1	1	1	1	1	1	1	1	1	0	0	0	0	0	0
	White	1	1	1	1	1	1	1	1	1	1	1	1	1	1	1	1	1	1
Gray Scale Of Red	Red(0)/Dark	0	0	0	0	0	0	0	0	0	0	0	0	0	0	0	0	0	0
	Red(1)	0	0	0	0	0	1	0	0	0	0	0	0	0	0	0	0	0	0
	Red(2)	0	0	0	0	1	0	0	0	0	0	0	0	0	0	0	0	0	0
	:	:	:	:	:	:	:	:	:	:	:	:	:	:	:	:	:	:	:
	:	:	:	:	:	:	:	:	:	:	:	:	:	:	:	:	:	:	:
	:	:	:	:	:	:	:	:	:	:	:	:	:	:	:	:	:	:	:
	Red(61)	1	1	1	1	0	1	0	0	0	0	0	0	0	0	0	0	0	0
	Red(62)	1	1	1	1	1	0	0	0	0	0	0	0	0	0	0	0	0	0
Red(63)	1	1	1	1	1	1	0	0	0	0	0	0	0	0	0	0	0	0	
Gray Scale Of Green	Green(0)/Dark	0	0	0	0	0	0	0	0	0	0	0	0	0	0	0	0	0	0
	Green(1)	0	0	0	0	0	0	0	0	0	0	0	1	0	0	0	0	0	0
	Green(2)	0	0	0	0	0	0	0	0	0	0	1	0	0	0	0	0	0	0
	:	:	:	:	:	:	:	:	:	:	:	:	:	:	:	:	:	:	:
	:	:	:	:	:	:	:	:	:	:	:	:	:	:	:	:	:	:	:
	:	:	:	:	:	:	:	:	:	:	:	:	:	:	:	:	:	:	:
	Green(61)	0	0	0	0	0	0	1	1	1	1	0	1	0	0	0	0	0	0
	Green(62)	0	0	0	0	0	0	1	1	1	1	1	0	0	0	0	0	0	0
Green(63)	0	0	0	0	0	0	1	1	1	1	1	1	0	0	0	0	0	0	
Gray Scale Of Blue	Blue(0)/Dark	0	0	0	0	0	0	0	0	0	0	0	0	0	0	0	0	0	0
	Blue(1)	0	0	0	0	0	0	0	0	0	0	0	0	0	0	0	0	0	1
	Blue(2)	0	0	0	0	0	0	0	0	0	0	0	0	0	0	0	0	1	0
	:	:	:	:	:	:	:	:	:	:	:	:	:	:	:	:	:	:	:
	:	:	:	:	:	:	:	:	:	:	:	:	:	:	:	:	:	:	:
	:	:	:	:	:	:	:	:	:	:	:	:	:	:	:	:	:	:	:
	Blue(61)	0	0	0	0	0	0	0	0	0	0	0	0	1	1	1	1	0	1
	Blue(62)	0	0	0	0	0	0	0	0	0	0	0	0	1	1	1	1	1	0
Blue(63)	0	0	0	0	0	0	0	0	0	0	0	0	1	1	1	1	1	1	

Note (1) 0: Low Level Voltage, 1: High Level Voltage

6. INTERFACE TIMING

6.1 INPUT SIGNAL TIMING SPECIFICATIONS

The input signal timing specifications are shown as the following table and timing diagram.

Signal	Item	Symbol	Min.	Typ.	Max.	Unit	Note
Dot Clock	Frequency	Fc	21	25.175	29	MHz	-
	Duty		0.4	0.5	0.6		
Dot Data	Setup Time	Tlvs	8	-	-	ns	-
	Hold Time	Tlvh	12	-	-	ns	-
Horizontal Active Display Term	Frame Rate	Fr	-	60	-	Hz	Tv=Tvd+Tvb
	Total	Tv	730	800	900	Th	-
	Display	Tvd		640		Th	-
	Blank	Tvb	90	160	260	Th	-
Vertical Active Display Term	Total	Th	485	525	800	Tc	Th=Thd+Thb
	Display	Thd		480		Tc	-
	Blank	Thb	5	45	320	Tc	-

Note : (1) This module is operated by DE only mode

(2) Frame rate is 60Hz

INPUT SIGNAL TIMING DIAGRAM

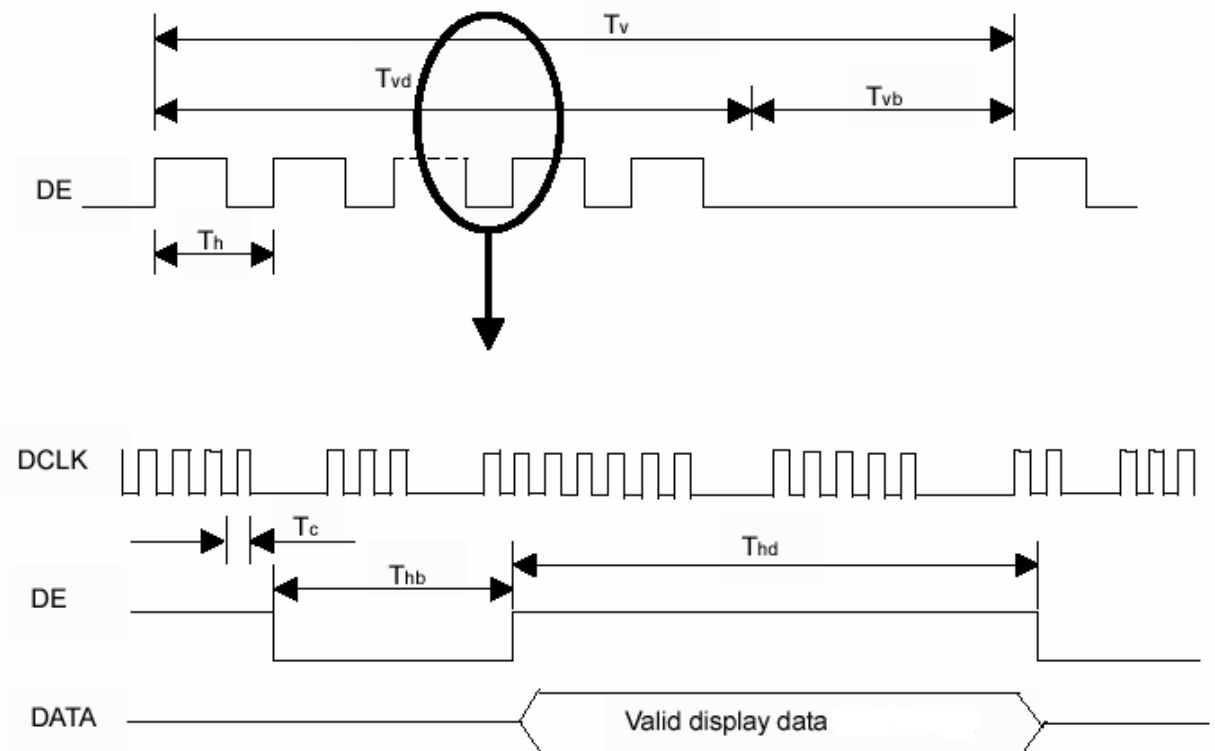

6.2 POWER ON/OFF SEQUENCE

To prevent a latch-up or DC operation of LCD module, the power on/off sequence should follow the conditions shown in the following diagram.

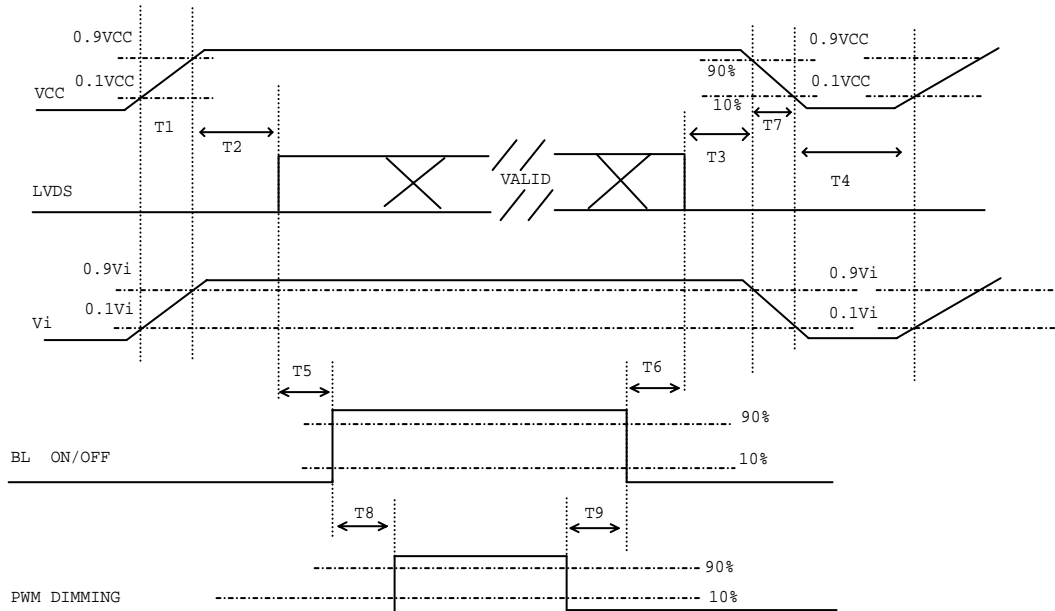

Power ON/OFF sequence

Note (1) Please avoid floating state of interface signal at invalid period.

Note (2) When the interface signal is invalid, be sure to pull down the power supply of LCD VCC to 0 V.

Note (3) The Backlight converter power must be turned on after the power supply for the logic and the interface signal is valid. The Backlight converter power must be turned off before the power supply for the logic and the interface signal is invalid.

Parameter	Value			Units
	Min	Typ	Max	
T1	0.5	-	10	ms
T2	0	-	50	ms
T3	0	-	50	ms
T4	500	-	-	ms
T5	200	-	-	ms
T6	20	-	-	ms
T7	5	-	300	ms
T8	10	-	-	ms
T9	10	-	-	ms

6.3 SCANNING DIRECTION

The following figures show the image see from the front view. The arrow indicates the direction of scan.



Figure1.Normal scan (DPSR : Low or Open)

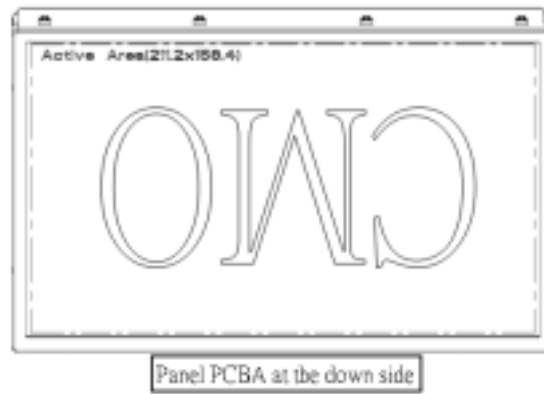

Figure 2. Reverse scan (DPSR : High)

7. OPTICAL CHARACTERISTICS

7.1 TEST CONDITIONS

Item	Symbol	Value	Unit
Ambient Temperature	Ta	25±2	°C
Ambient Humidity	Ha	50±10	%RH
Supply Voltage	VCC	3.3	V
Input Signal	According to typical value in "3. ELECTRICAL CHARACTERISTICS"		
Converter Voltage	V _i	12	V
Converter Duty		100	%

7.2 OPTICAL SPECIFICATIONS

The relative measurement methods of optical characteristics are shown in 7.2. The following items should be measured under the test conditions described in 7.1 and stable environment shown in Note (5).

Item	Symbol	Condition	Min.	Typ.	Max.	Unit	Note				
Color Chromaticity	Red	$\theta_x=0^\circ, \theta_y=0^\circ$ CS-1000	Typ - 0.05	0.619	Typ + 0.05	-	(1), (5)				
				0.357		-					
	Green			0.333		-					
				0.562		-					
	Blue			0.145		-					
				0.092		-					
	White			0.313		-					
				0.329		-					
	Center Luminance of White			L _C		450		500	-	-	(4), (5)
	Contrast Ratio			CR		1000		1500	-	-	(2), (5)
Response Time	T _R	$\theta_x=0^\circ, \theta_y=0^\circ$	-	14	19	ms	(3)				
	T _F		-	9	14	ms					
White Variation	δW	$\theta_x=0^\circ, \theta_y=0^\circ$	-	-	1.4	-	(5), (6)				
Viewing Angle	Horizontal	CR≥10	80	88	-	Deg.	(1), (5)				
			80	88	-						
	Vertical		80	88	-						
			80	88	-						

Note (1) Definition of Viewing Angle (θ_x, θ_y):

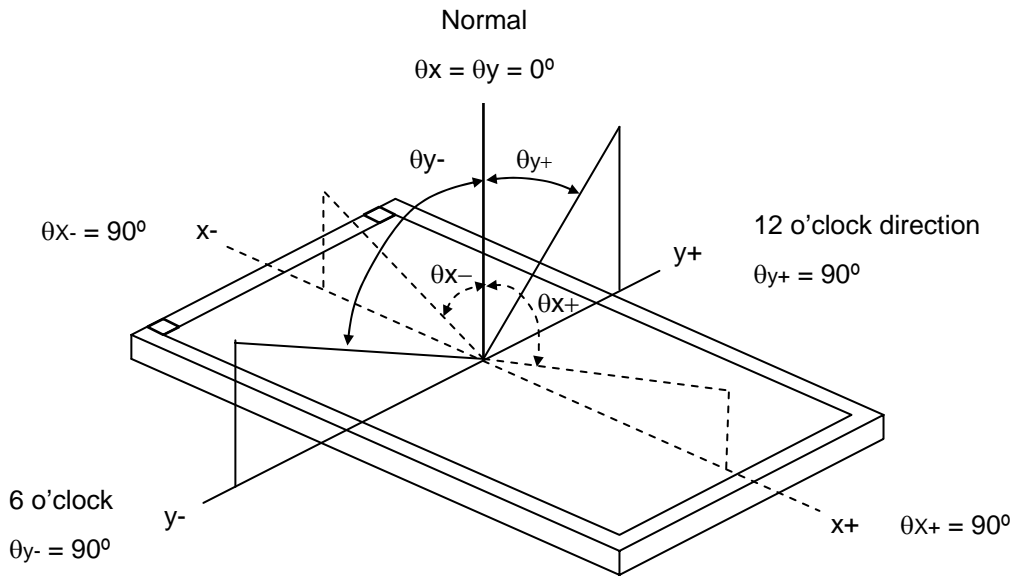

Note (2) Definition of Contrast Ratio, (CR):

The contrast ratio can be calculated by the following expression.

$$\text{Contrast Ratio, CR} = L_{63} / L_0$$

L63: Luminance of gray level 63

L 0: Luminance of gray level 0

$$\text{CR} = \text{CR} (5)$$

CR (X) is corresponding to the Contrast Ratio of the point X at Figure in Note (5).

Note (3) Definition of Response Time (T_R, T_F) and measurement method:

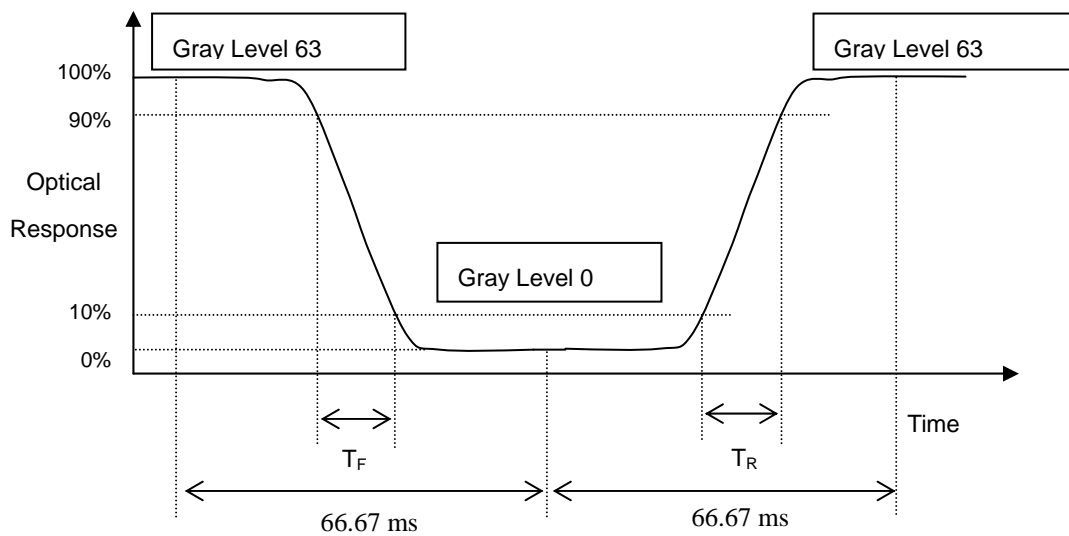

Note (4) Definition of Luminance of White (L_C):

Measure the luminance of gray level 63 at center point and 5 points

$L_C = L(5)$, where $L(X)$ is corresponding to the luminance of the point X at the figure in Note (7).

Note (5) Measurement Setup:

The LCD assembly should be stabilized at given temperature for 30 minutes to avoid abrupt temperature change during measuring. In order to stabilize the luminance, the measurement should be executed after lighting Backlight for 30 minutes in a windless room.

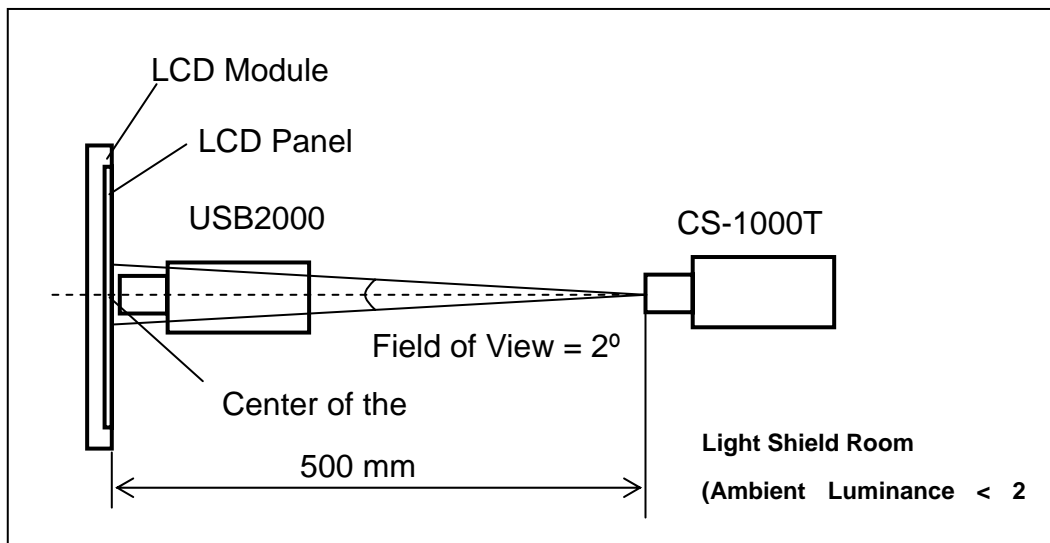

Note (6) Definition of White Variation (δW):

Measure the luminance of gray level 63 at 5 points

$\delta W = \text{Maximum} [L(1), L(2), L(3), L(4), L(5)] / \text{Minimum} [L(1), L(2), L(3), L(4), L(5)]$

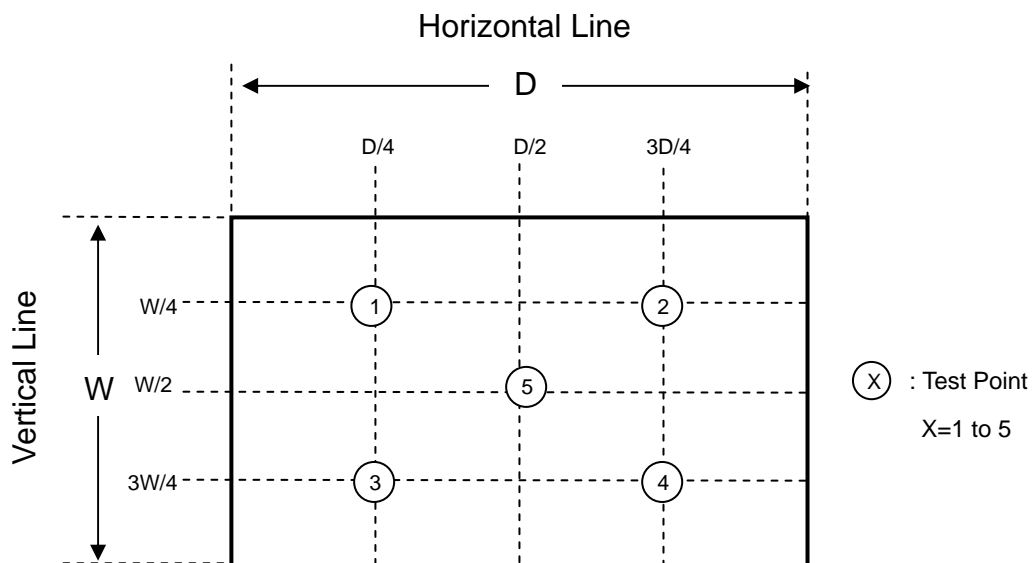

8. Reliability Test Criteria

Test Item	Test Condition	Note	
High Temperature Storage Test	80°C, 240 hours	(1) (2) (4)	
Low Temperature Storage Test	-30°C, 240 hours		
Thermal Shock Storage Test	-30°C, 0.5hour 80 , 0.5hour; 100cycles, 1hour/cycle		
High Temperature Operation Test	80°C, 240 hours		
Low Temperature Operation Test	-30°C, 240 hours		
High Temperature & High Humidity Operation Test	60°C, 90%RH, 240hours		
Shock (Non-Operating)	200G, 2ms, half sine wave, 1 time for $\pm X$, $\pm Y$, $\pm Z$.		(3) (4)
Vibration (Non-Operating)	1.5G, 10 ~ 300 Hz, 10min/cycle, 3 cycles each X, Y, Z		(3) (4)

Note (1) There should be no condensation on the surface of panel during test.

Note (2) Temperature of panel display surface area should be 85 °C Max.

Note (3) At testing Vibration and Shock, the fixture in holding the module has to be hard and rigid enough so that the module would not be twisted or bent by the fixture.

Note (4) In the standard conditions, there is no function failure issue occurred. All the cosmetic specification is judged before reliability test.

9. PACKAGING

9.1 PACKING SPECIFICATIONS

- (1) 18pcs LCD modules / 1 Box
- (2) Box dimensions: 465 (L) X 362 (W) X 314 (H) mm
- (3) Weight: approximately 11.23Kg (18 modules per box)

9.2 PACKING METHOD

- (1) Carton Packing should have no failure in the following reliability test items.

Test Item	Test Conditions	Note
Vibration	ISTA STANDARD Random, Frequency Range: 2 – 200 Hz Top & Bottom: 30 minutes (+Z), 10 min (-Z), Right & Left: 10 minutes (X) Back & Forth 10 minutes (Y)	Non Operation
Dropping Test	1 Angle, 3 Edge, 6 Face, 61 cm	Non Operation

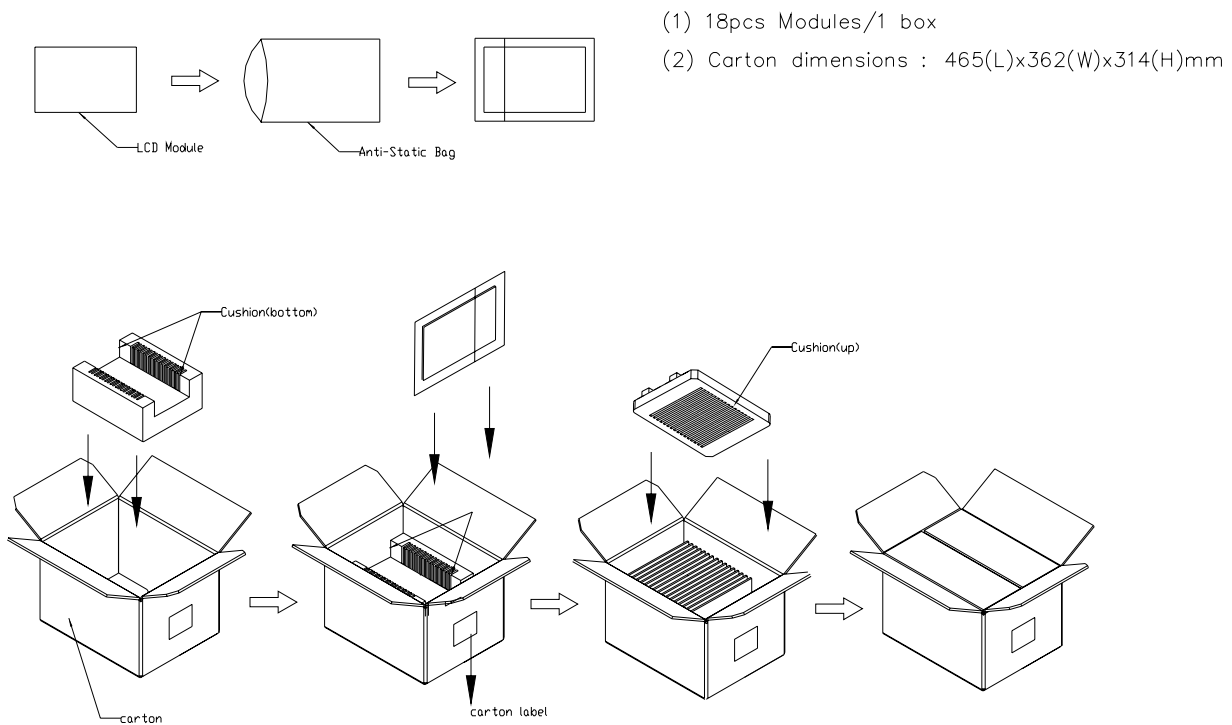
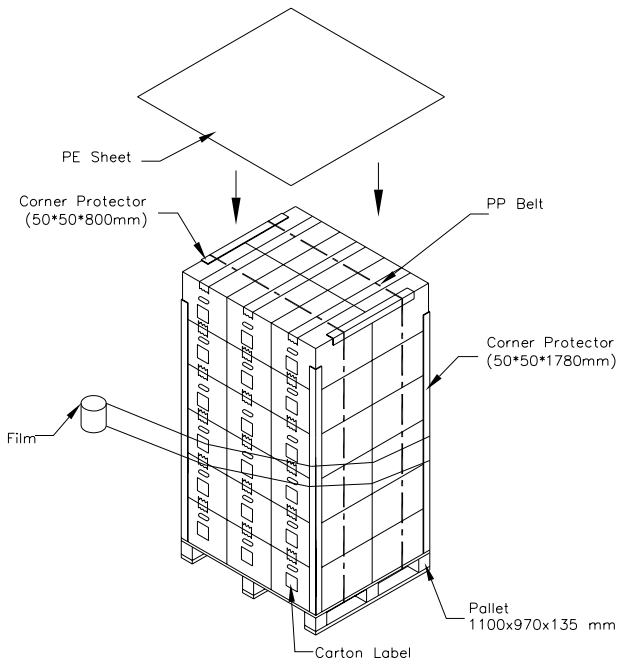

Figure. 9-1 Packing method

Sea / Land Transportation (40ft Container)



Air Transportation

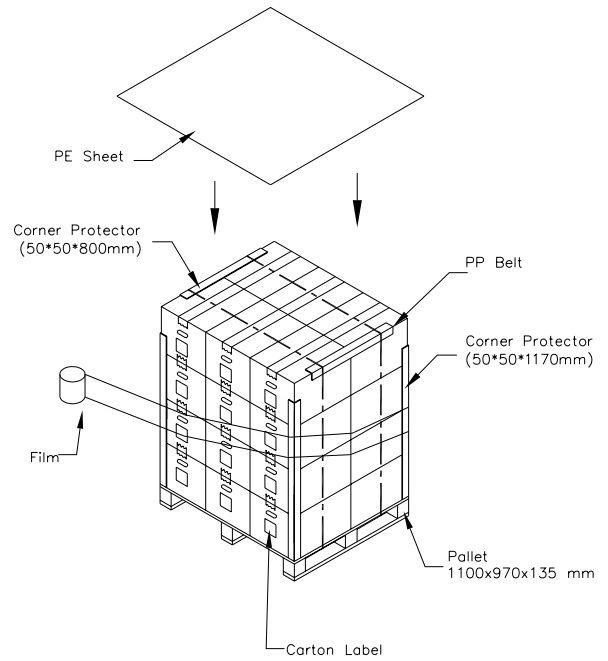
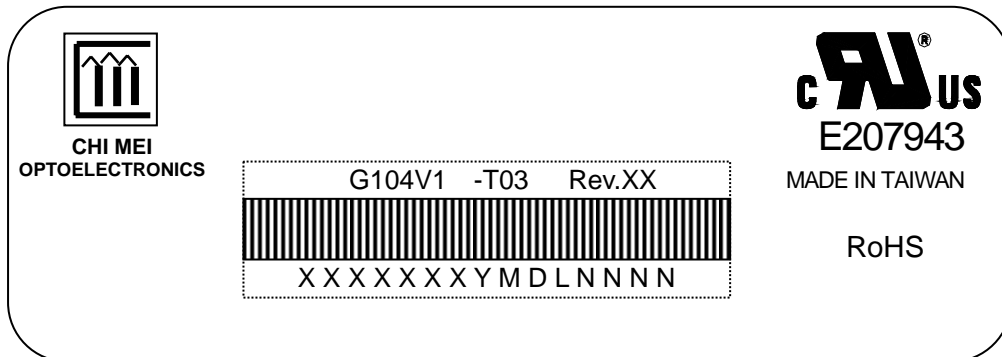

Figure. 9-2 Packing method

10. DEFINITION OF LABELS

10.1 CMO MODULE LABEL

The barcode nameplate is pasted on each module as illustration, and its definitions are as following explanation.



- (a) Model Name: G104V1 –T03
- (b) Revision: Rev. XX, for example: A1, ...C1, C2 ...etc.
- (c) Serial ID: X X X X X X Y M D X N N N N

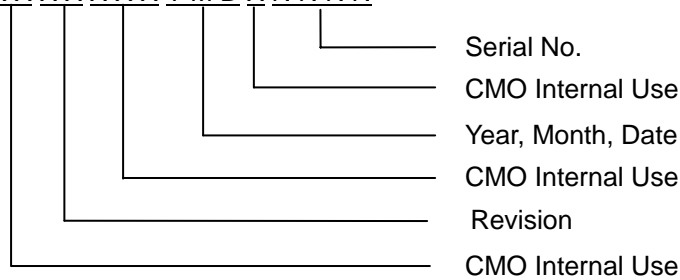

Serial ID includes the information as below:

- (a) Manufactured Date: Year: 0~9, for 2010~2019
 Month: 1~9, A~C, for Jan. ~ Dec.
 Day: 1~9, A~Y, for 1st to 31st, exclude I , O and U
- (b) Revision Code: cover all the change
- (c) Serial No.: Manufacturing sequence of product

11. PRECAUTIONS

11.1 ASSEMBLY AND HANDLING PRECAUTIONS

- (1) Do not apply rough force such as bending or twisting to the module during assembly.
- (2) To assemble or install module into user's system can be only in clean working areas. The dust and oil may cause electrical short or worsen the polarizer.
- (3) It's not permitted to have pressure or impulse on the module because the LCD panel and Backlight will be damaged.
- (4) Always follow the correct power sequence when LCD module is connecting and operating. This can prevent damage to the CMOS LSI chips during latch-up.
- (5) Do not pull the I/F connector in or out while the module is operating.
- (6) Do not disassemble the module.
- (7) Use a soft dry cloth without chemicals for cleaning, because the surface of polarizer is very soft and easily scratched.
- (8) It is dangerous that moisture come into or contacted the LCD module, because moisture may damage LCD module when it is operating.
- (9) High temperature or humidity may reduce the performance of module. Please store LCD module within the specified storage conditions.
- (10) When ambient temperature is lower than 10°C may reduce the display quality, the response time will become slowly.
- (11) Do not keep same pattern in a long period of time. It may cause image sticking on LCD.

11.2 SAFETY PRECAUTIONS

- (1) Do not disassemble the module or insert anything into the Backlight unit.
- (2) If the liquid crystal material leaks from the panel, it should be kept away from the eyes or mouth. In case of contact with hands, skin or clothes, it has to be washed away thoroughly with soap.
- (3) After the module's end of life, it is not harmful in case of normal operation and storage.

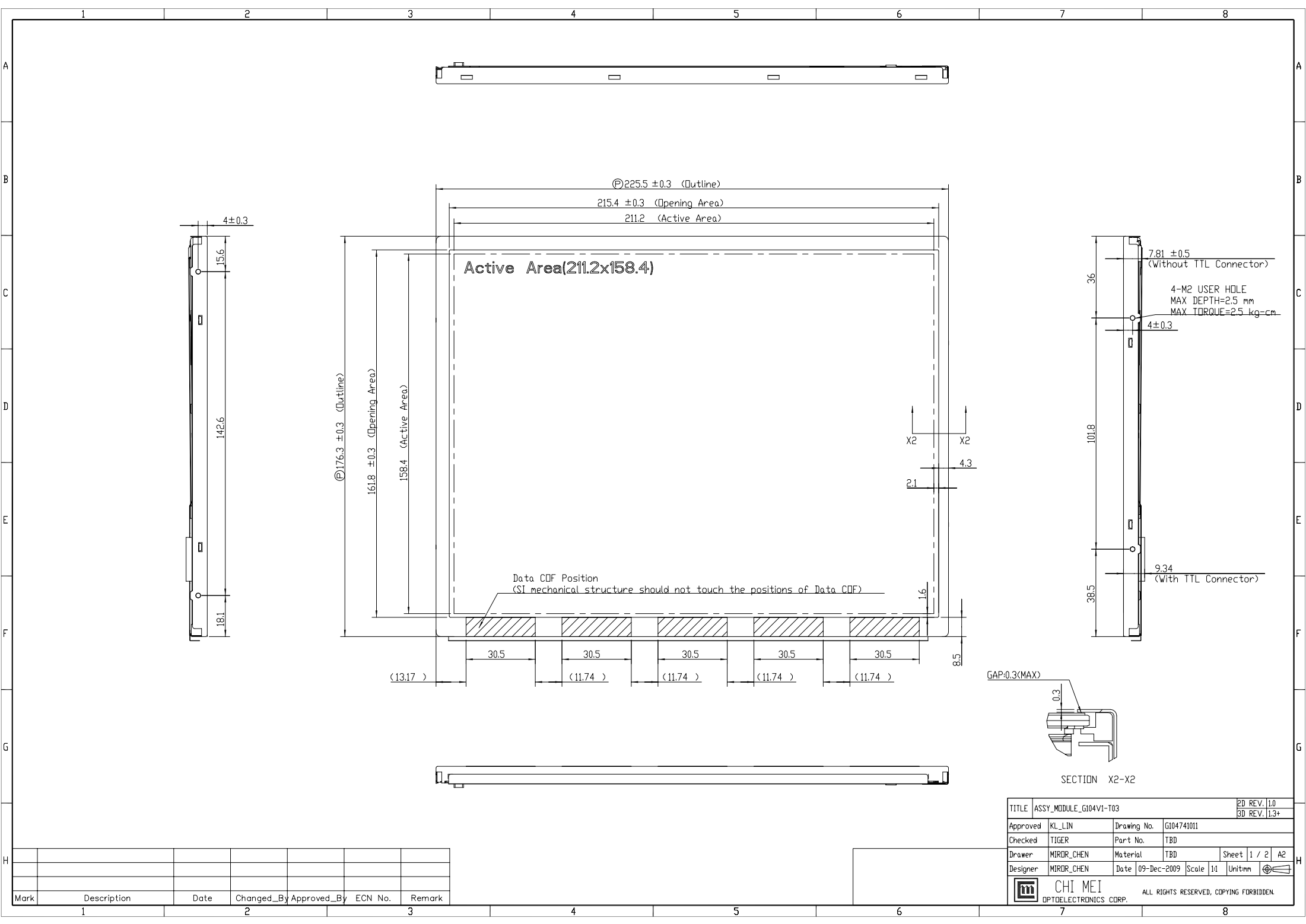

Mark	Description	Date	Changed_By	Approved_By	ECN No.	Remark

TITLE	ASSY_MODULE_G104V1-T03			2D REV: 1.0
				3D REV: 1.3+
Approved	KL_LIN	Drawing No.	G104741011	
Checked	TIGER	Part No.	TBD	
Drawer	MIROR_CHEN	Material	TBD	Sheet 1 / 2 A2
Designer	MIROR_CHEN	Date	09-Dec-2009	Scale 1:1 Unit:mm
		CHI MEI OPTOELECTRONICS CORP.		
ALL RIGHTS RESERVED, COPYING FORBIDDEN.				

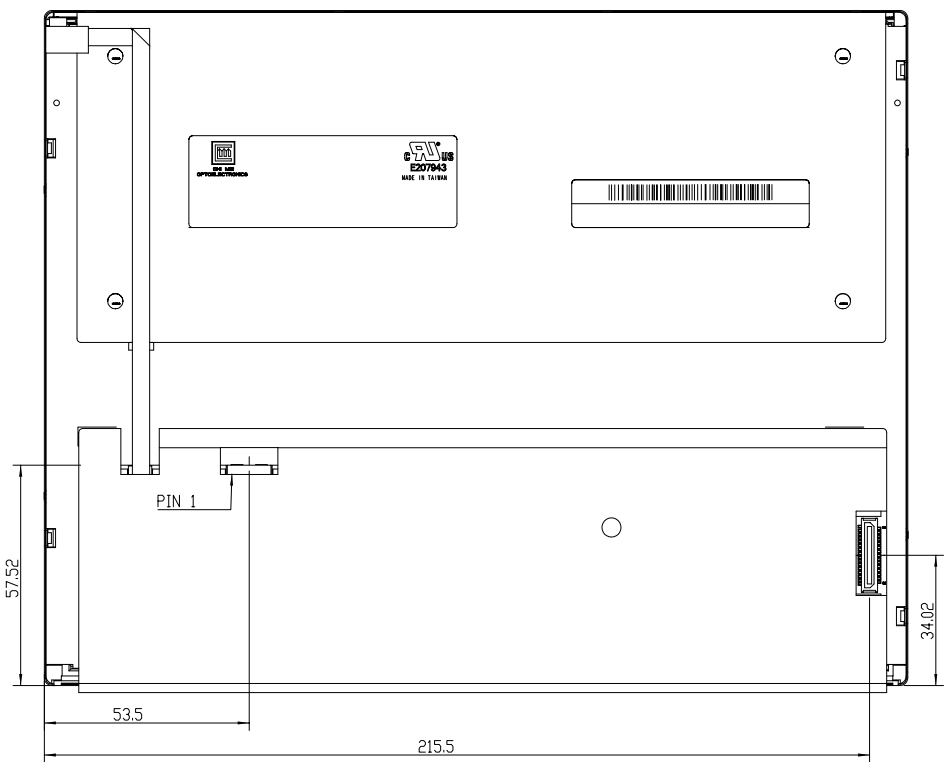

TITLE	ASSY_MODULE_G104V1-T03			2D REV. 1.0
				3D REV. 1.3+
Approved	KL_LIN	Drawing No.	G104741011	
Checked	TIGER	Part No.	TBD	
Drawer	MIROR_CHEN	Material	TBD	Sheet 2 / 2 A2
Designer	MIROR_CHEN	Date	24-Feb-2010	Scale 1:1 Unit:mm
 CHI MEI OPTOELECTRONICS CORP.		ALL RIGHTS RESERVED, COPYING FORBIDDEN.		

Mark	Description	Date	Changed_By	Approved_By	ECN No.	Remark