

TFT LCD Approval Specification

MODEL NO.: G070Y3-T01

Customer: _____

Approved by: _____

Note:

記錄	工作	審核	角色	投票
2008-03-10 16:44:39 CST	PMMD Director	cs_lee(李志聖 /17564/44926)	Director	Accept

- CONTENTS -

REVISION HISTORY	-----	3
1. GENERAL DESCRIPTION	-----	4
1.1 OVERVIEW		
1.2 FEATURES		
1.3 APPLICATION		
1.4 GENERAL SPECIFICATIONS		
1.5 MECHANICAL SPECIFICATIONS		
2. ABSOLUTE MAXIMUM RATINGS	-----	6
2.1 ABSOLUTE RATINGS OF ENVIRONMENT		
2.2 ELECTRICAL ABSOLUTE RATINGS		
2.2.1 TFT LCD MODULE		
2.2.2 BACKLIGHT UNIT		
3. ELECTRICAL CHARACTERISTICS	-----	8
3.1 RECOMMENDED OPERATING CONDITION		
3.2 CURRENT CONSUMPTION		
3.3 BACKLIGHT UNIT		
4. BLOCK DIAGRAM	-----	10
4.1 TFT LCD MODULE		
4.2 BACKLIGHT UNIT		
5. INPUT TERMINAL PIN ASSIGNMENT	-----	11
5.1 FPC I/O PIN ASSIGNMENT		
5.2 BACKLIGHT FPC PIN ASSIGNMENT		
5.3 SCANNING DIRECTION		
5.4 COLOR DATA INPUT ASSIGNMENT		
6. INTERFACE TIMING	-----	15
6.1 AC ELECTRICAL CHARACTERISTICS		
6.2 POWER ON/OFF SEQUENCE		
7. OPTICAL CHARACTERISTICS	-----	18
7.1 TEST CONDITIONS		
7.2 OPTICAL SPECIFICATIONS		
8. PACKAGING	-----	21
9. DEFINITION OF LABELS	-----	23
10. PRECAUTIONS	-----	24
11. APPLICATION NOTES	-----	25
11.1 GAMMA CIRCUIT		
12. MECHANICAL CHARACTERISTICS	-----	26

REVISION HISTORY

Version	Date	Section	Description
Ver 2.0	Feb. 15, '08	All	G070Y3-T01 Approval specification was first issued.

1. GENERAL DESCRIPTION

1.1 OVERVIEW

G070Y3-T01 is a 6.95inch TFT Liquid Crystal Display module with a LED backlight unit and a-50-pin-and-1ch-TTL interface. This module supports 800 (R.G.B)x 480 WVGA mode which main application is the automotive Monitor and industrial field.

1.2 FEATURES

- Wide viewing angle.
- Fast response time
- WVGA (800 x 480 pixels) resolution
- Wide operating temperature
- Reversible - scan function
- Digital interface
- LED light bar replaceable

1.3 APPLICATION

- Automotive Monitor
- Industry Application

1.4 GENERAL SPECIFICATIONS

Item	Specification	Unit	Note
Diagonal Size	6.95 Inches	mm	
Active Area	156 x 82.8	mm	(1)
Bezel Opening Area	159.3 x 86	mm	
Driver Element	a-si TFT active matrix	-	-
Pixel Number	800 x R.G.B. x 480	pixel	-
Pixel Pitch	0.1950 x 0.1725	mm	-
Pixel Arrangement	RGB vertical stripe	-	(2)
Display Colors	262.144 (6 bits)	color	-
Display Mode	Normal White	-	-
Surface Treatment	Hard Coating (3H), AG (Haze 25 %)	-	-
Weight	180(Typ)	g	

Note (1) Please refer to the attached drawings for more information of front and back outline dimensions.

Note (2)

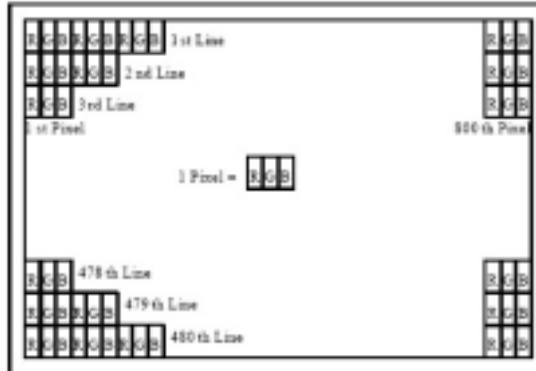

1.5 MECHANICAL SPECIFICATIONS

Item		Min.	Typ.	Max.	Unit	Note
Module Size	Horizontal(H)	167.7	168	168.3	mm	(1)
	Vertical(V)	93.7	94	94.3	mm	
	Depth(D)	6.05	6.35	6.65	mm	

Note (1) Please refer to the attached drawings for more information of front and back outline dimensions.

2. ABSOLUTE MAXIMUM RATINGS

2.1 ABSOLUTE RATINGS OF ENVIRONMENT

No.	Test Item	Test Condition	Note
1	High Temperature Storage	90 , 240 hours	(1) (2)
2	Low Temperature Storage	-40 , 240 hours	
3	Thermal Shock Storage	{(-40 , 0.5 hour) (85 , 0.5 hour)}, 100 cycles	
4	High Temperature Operating	85 , 240 hours	
5	Low Temperature Operating	-30 , 240 hours	
6	High Temperature & High Humidity Operating	60 , 90% RH, 240hours	
7	Shock (Non-Operating)	100G, 6ms, +/-XYZ 3 times	(3)(5)
8	Vibration (Non-Operating)	3G, 10 to 200 Hz, sine wave	(4)(5)

Note (1) There should be no condensation on the surface of panel during test.

Note (2) The temperature of panel display surface area should be 90 Max.

Note (3) 6ms, half sine wave, 3 times for +/-X, +/-Y, +/-Z.

Note (4) 3 directions: X, Y and Z axes, 60min per each direction; 6 cycles; sweep time = 5 minutes; peak acceleration = 3G; frequency = 10 to 200 Hz; sine wave.

Note (5) At testing Vibration and Shock, the fixture in holding the module has to be hard and rigid enough so that the module would not be twisted or bent by the fixture.

Note (6) In the standard conditions, there is no function failure issue occurred. All the cosmetic specification is judged before the reliability test.

2.2 ELECTRICAL ABSOLUTE RATINGS

2.2.1 TFT LCD MODULE

Ta = 25 ± 2 °C

Parameter	Symbol	Value			Unit	Note
		Min.	Typ.	Max.		
Power Supply Voltage	VCC	-0.3	-	5	V	-
	AVDD	-0.3	-	13.5	V	-
	VGH	-0.3	-	42	V	-
	VGL	VGH-42	-	0.3	V	-
Digital Input Voltage	V _I	-0.5	-	V _{CC} +0.5	V	(1)
Gamma Supply Voltage	V1~V5	0.4AVDD	-	AVDD+0.3	V	-
	V6~V10	-0.3	-	0.6AVDD	V	-

Note (1) V_I means all input logic signal.

2.2.2 BACKLIGHT UNIT

Ta = 25 ± 2 °C

Item	Symbol	Value			Unit	Note
		Min.	Typ.	Max.		
LED Light Bar Power Supply Voltage	V _L	-45	-	31.5	V	(1)
LED Light Bar Power Supply Current	I _L	-	-	90	mA	(1)

Note (1) Permanent damage to the device may occur if maximum or minimum values are exceeded. Function operation should be restricted to the conditions described under Normal Operating Conditions.

3. ELECTRICAL CHARACTERISTICS

3.1 RECOMMENDED OPERATION CONDITION (GND = AVSS = 0V)

Ta = 25 ± 2 °C

Parameter	Symbol	Value			Unit	Note	
		Min.	Typ.	Max.			
Power Supply Voltage	VCC	3.0	3.3	3.6	V		
	AVDD	10.29	10.5	10.71	V		
	VGH	17.5	18	18.5	V		
	VGL	-7.5	-7	-6.5	V		
Input Signal Voltage	V1~V5	0.4AVDD	-	AVDD+0.3	V	(1)	
	V6~V10	-0.3	-	0.6AVDD	V	(1)	
	VCOM	-	4.035	-	V		
Digital Input Voltage	High Level	V _{IH}	0.7VCC	-	VCC	V	
	Low Level	V _{IL}	0	-	0.3VCC	V	

Note (1) Please refer to 11.1 application notes.

3.2 CURRENT CONSUMPTION (GND = AVSS = 0V)

Parameter	Symbol	Value			Unit	Note
		Min.	Typ.	Max.		
Supply Current for Source/Gate Driver (Digital)	I _{CC}	-	2.86	3.5	mA	(1)
Supply Current for Source Driver (Analog)	I _{DD}	-	21	25	mA	(1)
Supply Current for Gate Driver (High Level)	I _{GG}	-	0.13	0.2	mA	(1)
Supply Current for Gate Driver (Low Level)	I _{EE}	-	0.13	0.2	mA	(1)

Note (1) The specified power supply current is under the conditions at VCC = 3.3 V, Ta = 25 ± 2 °C, f_v = 60 Hz, whereas a power dissipation check pattern below is displayed.

Black Pattern

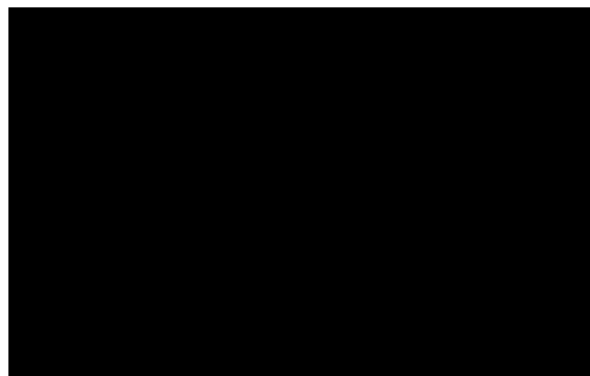

Active Area

3.3 BACKLIGHT UNIT

Ta = 25 ± 2 °C

Parameter	Symbol	Value			Unit	Note
		Min.	Typ.	Max.		
LED Quantity		27			PCs	(1)
LED Light Bar Power Supply Voltage	V _L	26.1	27.9	29.7	V	(1),(2) (Duty 100%)
LED Light Bar Power Supply Current	I _L	-	60	-	mA	
Power Consumption	P _L	-	1.674	-	W	(3), (Duty 100%)
LED Life Time	L _{BL}	10000	-	-	Hrs	(4)

Note (1) LED light bar configuration is shown as below.

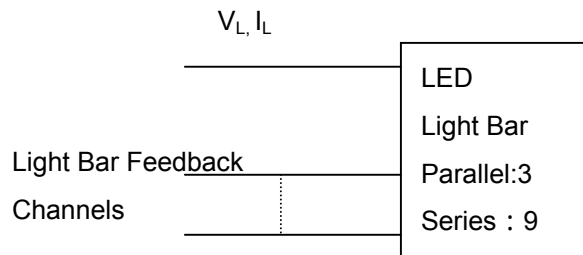

Note (2) For better LED light bar driving quality, it is recommended to utilize the adaptive boost converter with current balancing function to drive LED light-bar.

Note (3) $P_L = I_L \times V_L$

Note (4) The lifetime of LED is defined as the time when it continues to operate under the conditions at Ta = 25 ± 2 °C and I_L = 20 mA(Per EA) until the brightness becomes 50% of its original value.

4. BLOCK DIAGRAM

4.1 TFT LCD MODULE

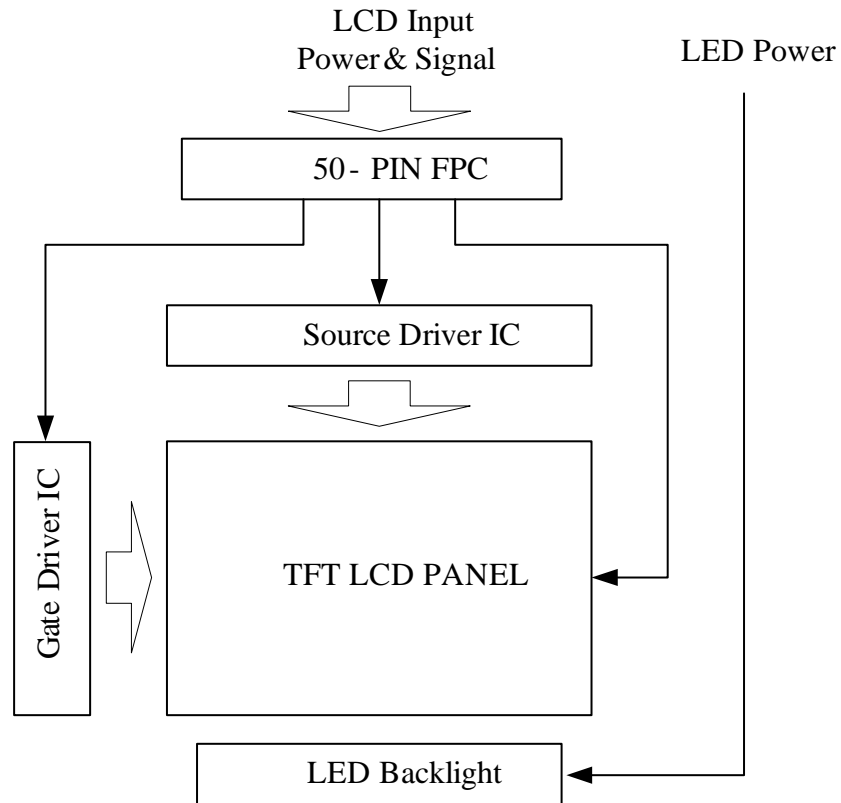

4.2 BACKLIGHT UNIT

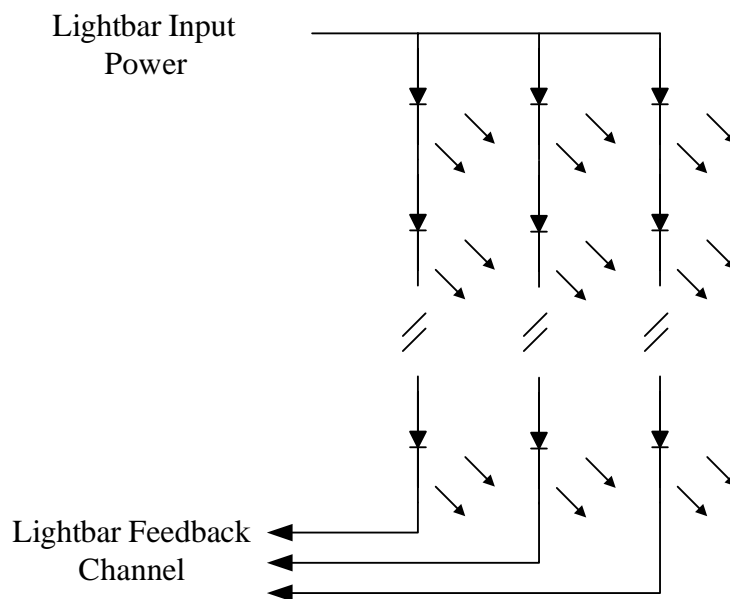

5. INPUT TERMINAL PIN ASSIGNMENT

5.1 FPC I/O PIN ASSIGNMENT

Pin	Name	I/O	Description
1	VCOM	I	VCOM Voltage
2	DIO1	I/O	Start Pulse Signal Input/Output (Horizontal)
3	CLK	I	Source Driver Shift Clock Input
4	SHL	I	Source Driver Shift Direction Control Input
5	D00	I	Red Data(R0)
6	D01	I	Red Data(R1)
7	D02	I	Red Data(R2)
8	D03	I	Red Data(R3)
9	D04	I	Red Data(R4)
10	D05	I	Red Data(R5)
11	D10	I	Green Data(G0)
12	D11	I	Green Data(G1)
13	D12	I	Green Data(G2)
14	D13	I	Green Data(G3)
15	D14	I	Green Data(G4)
16	D15	I	Green Data(G5)
17	V1	I	Gamma Voltage 1
18	V2	I	Gamma Voltage 2
19	V3	I	Gamma Voltage 3
20	V4	I	Gamma Voltage 4
21	V5	I	Gamma Voltage 5
22	V6	I	Gamma Voltage 6
23	V7	I	Gamma Voltage 7
24	V8	I	Gamma Voltage 8
25	V9	I	Gamma Voltage 9
26	V10	I	Gamma Voltage 10
27	D20	I	Blue Data(B0)
28	D21	I	Blue Data(B1)
29	D22	I	Blue Data(B2)
30	D23	I	Blue Data(B3)
31	D24	I	Blue Data(B4)
32	D25	I	Blue Data(B5)
33	LD	I	Latching and Data Switching Input
34	REV	I	Data Inverting Input
35	POL	I	Polarity Inverting Input
36	VCC	I	Digital Supply Voltage
37	GND	I	Ground
38	AVDD	I	Source Driver Analog Supply Voltage
39	DIO2	I/O	Start Pulse Signal Input/Output (Horizontal)
40	GND	I	Ground

41	XAO	I	Output All-on Control
42	OE	I	Gate Driver Output Enable Control
43	UD_RL	I	Up/Down Scan Selection
44	CKV	I	Gate Driver Shift Clock input
45	STVU	I/O	Start Pulse Signal Input/Output (Vertical)
46	STVD	I/O	Start Pulse Signal Input/Output (Vertical)
47	VCC	I	Digital Supply Voltage
48	VGL	I	TFT Low Voltage
49	VGH	I	TFT High Voltage
50	GND	I	Ground

Note (1) User's connector Part No: 089H50-000000-G2-C (Starconn) or equivalent

5.2 BACKLIGHT FPC PIN ASSIGNMENT

Pin	Name	I/O	Description
1	V _L	I	LED Light-bar Input Power
2	CH1	O	Light-bar Feedback Channel
3	CH2	O	Light-bar Feedback Channel
4	CH3	O	Light-bar Feedback Channel

Note (1) User's connector Part No: EZ24004G213 (UNE) or equivalent

5.3 SCANNING DIRECTION

The following figures are seen from a front view and the arrow shows the direction of scan.

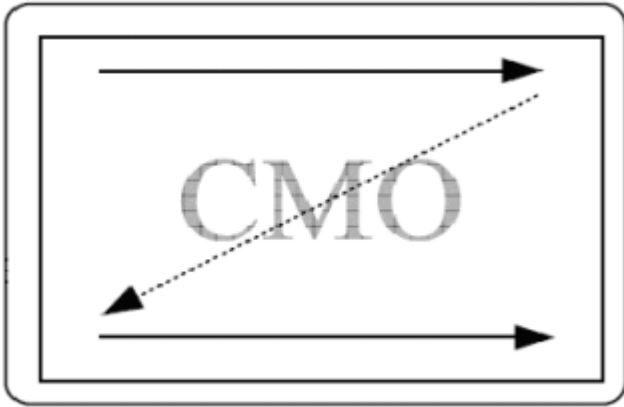

Figure1.Normal scan

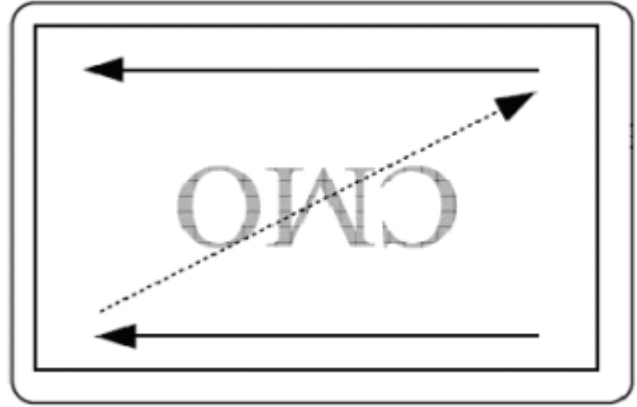

Figure 2. Reverse scan

Note : (1) Normal Scan

SHL	U/D	DIO1	DIO2	STVU	STVD	Shift
1	0	Input	Output	Input	Output	Up to down Left to right

(2) Reverse Scan

SHL	U/D	DIO1	DIO2	STVU	STVD	Shift
0	1	Output	Input	Output	Input	Down to Up Right to left

5.4 COLOR DATA INPUT ASSIGNMENT

The brightness of each primary color (red, green and blue) is based on the 6-bit gray scale data input for the color. The higher the binary input, the brighter the color. The table below provides the assignment of color versus data input. (0: Low Level Voltage, 1: High Level Voltage)

Color		Data Signal																	
		Red						Green						Blue					
		R5	R4	R3	R2	R1	R0	G5	G4	G3	G2	G1	G0	B5	B4	B3	B2	B1	B0
Basic Colors	Black	0	0	0	0	0	0	0	0	0	0	0	0	0	0	0	0	0	0
	Red	1	1	1	1	1	1	0	0	0	0	0	0	0	0	0	0	0	0
	Green	0	0	0	0	0	0	1	1	1	1	1	1	0	0	0	0	0	0
	Blue	0	0	0	0	0	0	0	0	0	0	0	0	1	1	1	1	1	1
	Cyan	0	0	0	0	0	0	1	1	1	1	1	1	1	1	1	1	1	1
	Magenta	1	1	1	1	1	1	0	0	0	0	0	0	1	1	1	1	1	1
	Yellow	1	1	1	1	1	1	1	1	1	1	1	1	0	0	0	0	0	0
	White	1	1	1	1	1	1	1	1	1	1	1	1	1	1	1	1	1	1
Gray Scale Of Red	Red(0) / Dark	0	0	0	0	0	0	0	0	0	0	0	0	0	0	0	0	0	0
	Red(1)	0	0	0	0	0	1	0	0	0	0	0	0	0	0	0	0	0	0
	Red(2)	0	0	0	0	1	0	0	0	0	0	0	0	0	0	0	0	0	0
	⋮	⋮	⋮	⋮	⋮	⋮	⋮	⋮	⋮	⋮	⋮	⋮	⋮	⋮	⋮	⋮	⋮	⋮	⋮
	⋮	⋮	⋮	⋮	⋮	⋮	⋮	⋮	⋮	⋮	⋮	⋮	⋮	⋮	⋮	⋮	⋮	⋮	⋮
	Red(61)	1	1	1	1	0	1	0	0	0	0	0	0	0	0	0	0	0	0
	Red(62)	1	1	1	1	1	0	0	0	0	0	0	0	0	0	0	0	0	0
	Red(63)	1	1	1	1	1	1	0	0	0	0	0	0	0	0	0	0	0	0
Gray Scale Of Green	Green(0) / Dark	0	0	0	0	0	0	0	0	0	0	0	0	0	0	0	0	0	0
	Green(1)	0	0	0	0	0	0	0	0	0	0	1	0	0	0	0	0	0	0
	Green(2)	0	0	0	0	0	0	0	0	0	0	1	0	0	0	0	0	0	0
	⋮	⋮	⋮	⋮	⋮	⋮	⋮	⋮	⋮	⋮	⋮	⋮	⋮	⋮	⋮	⋮	⋮	⋮	⋮
	⋮	⋮	⋮	⋮	⋮	⋮	⋮	⋮	⋮	⋮	⋮	⋮	⋮	⋮	⋮	⋮	⋮	⋮	⋮
	Green(61)	0	0	0	0	0	0	1	1	1	1	0	1	0	0	0	0	0	0
	Green(62)	0	0	0	0	0	0	1	1	1	1	1	0	0	0	0	0	0	0
	Green(63)	0	0	0	0	0	0	1	1	1	1	1	1	0	0	0	0	0	0
Gray Scale Of Blue	Blue(0) / Dark	0	0	0	0	0	0	0	0	0	0	0	0	0	0	0	0	0	0
	Blue(1)	0	0	0	0	0	0	0	0	0	0	0	0	0	0	0	0	0	1
	Blue(2)	0	0	0	0	0	0	0	0	0	0	0	0	0	0	0	0	1	0
	⋮	⋮	⋮	⋮	⋮	⋮	⋮	⋮	⋮	⋮	⋮	⋮	⋮	⋮	⋮	⋮	⋮	⋮	⋮
	⋮	⋮	⋮	⋮	⋮	⋮	⋮	⋮	⋮	⋮	⋮	⋮	⋮	⋮	⋮	⋮	⋮	⋮	⋮
	Blue(61)	0	0	0	0	0	0	0	0	0	0	0	0	1	1	1	1	0	1
	Blue(62)	0	0	0	0	0	0	0	0	0	0	0	0	1	1	1	1	1	0
	Blue(63)	0	0	0	0	0	0	0	0	0	0	0	0	1	1	1	1	1	1

6. INTERFACE TIMING

6.1 AC ELECTRICAL CHARACTERISTICS (VCC = 3.3V, AVDD = 8.4V, AVSS = GND = 0V, Ta = 25)

Parameter	Symbol	Value			Unit	Condition
		Min.	Typ.	Max.		
CLK frequency	Fclk	-	40	45	MHz	-
CLK Pulse width	Tcw	40%	-	60%	T _{CLK}	-
Data setup time	Tsu	4	-	-	ns	D00~D25, REV and DIO1/2 to CLK
Data hold time	Thd	2	-	-	ns	D00~D25, REV and DIO1/2 to CLK
Propagation delay of DIO2/1	Tphl	6	10	15	ns	CL = 25pF (Output)
Time that the last data to LD	Tld	1	-	-	T _{CLK}	-
Pulse width of LD	Twld	2	-	-	T _{CLK}	-
Time that LD to DIO1/2	Tlds	5	-	-	T _{CLK}	-
POL setup time	Tpsu	6	-	-	ns	POL to LD
POL hold time	Tphd	6	-	-	ns	POL to LD
Output stable time	Tst	-	-	12	us	10% or 90% target voltage, CL = 60pF, R = 2KΩ
CKV period	t _{CPV}	5	-	-	us	-
CKV pulse width	t _{CPVH} , t _{CPVL}	2.5	-	-	us	50% duty cycle
OE pulse width	t _{WOE}	1	-	-	us	-
XAO pulse width	t _{WXAO}	10	-	-	us	-
Data setup time	t _{su}	700	-	-	ns	-
Data hold time	t _{hd}	700	-	-	ns	-
Output delay time (1)	t _{Pd1}	-	-	1000	ns	CL = 300pF
Output delay time (2)	t _{Pd2}	-	-	800	ns	CL = 30pF
Output delay time (3)	t _{Pd3}	-	-	800	ns	CL = 300pF
Output delay time (4)	t _{Pd4}	-	-	10000	ns	CL = 300pF

■ Timing Diagram 1

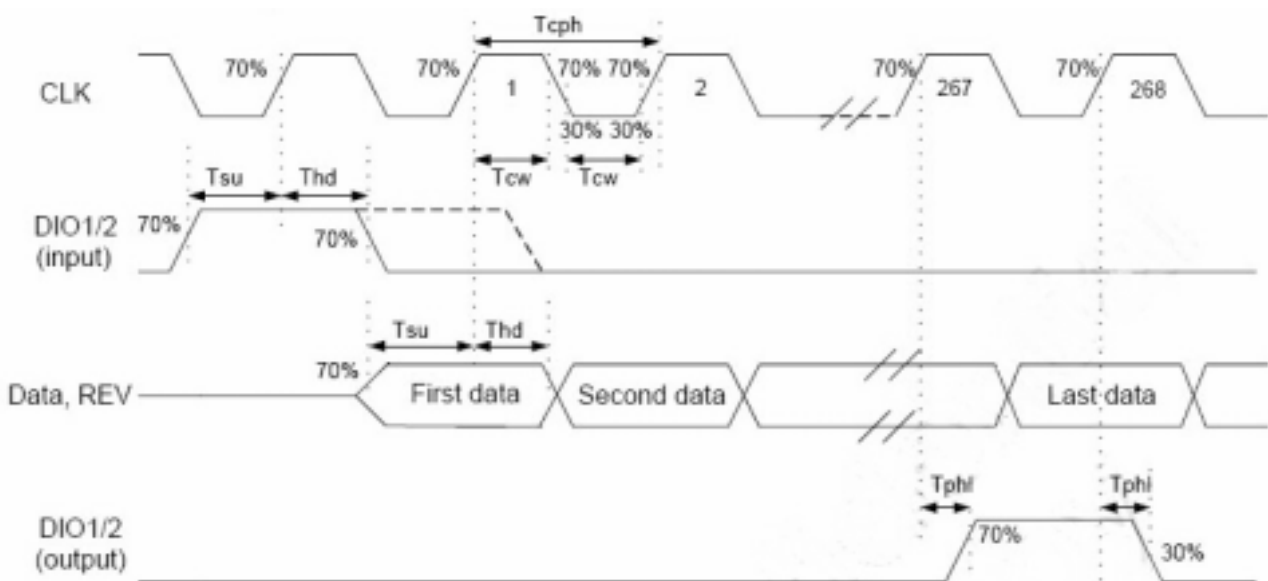

■Timing Diagram 2

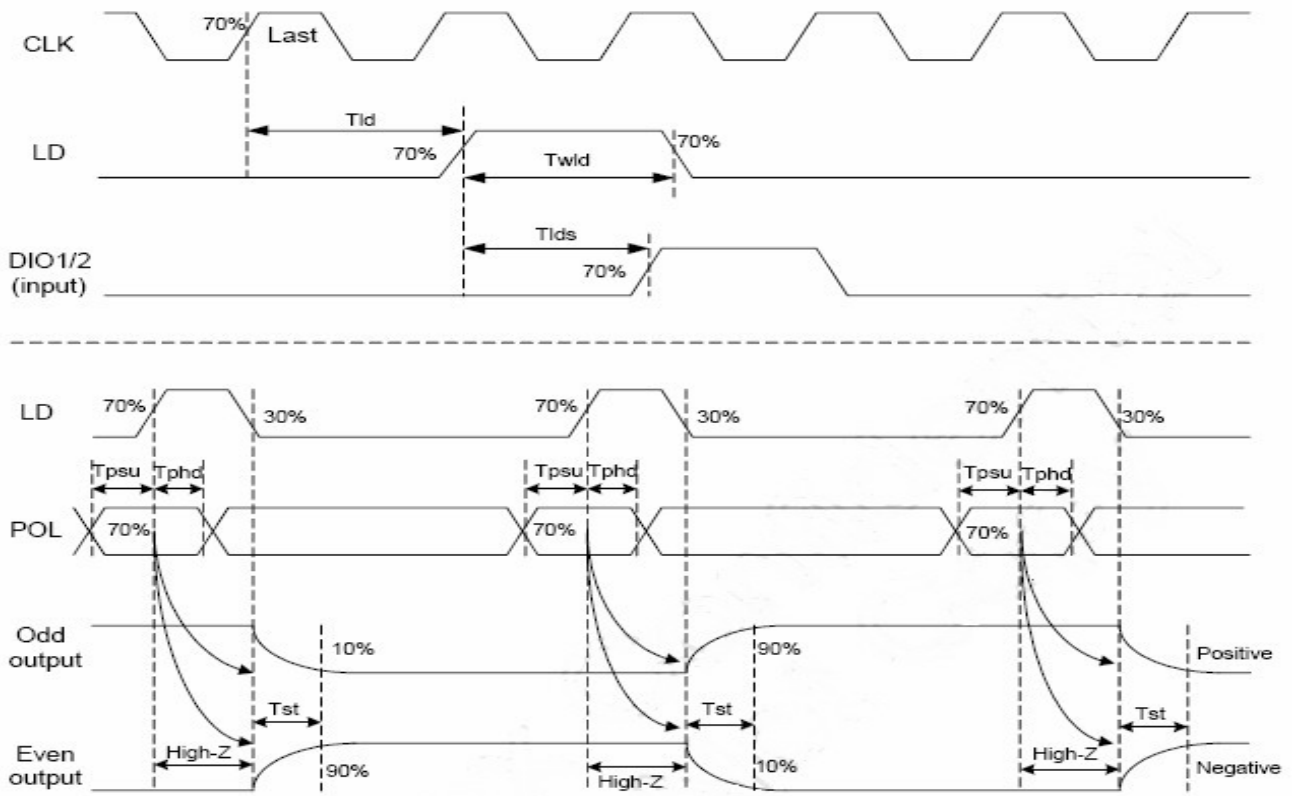

■Timing Diagram 3

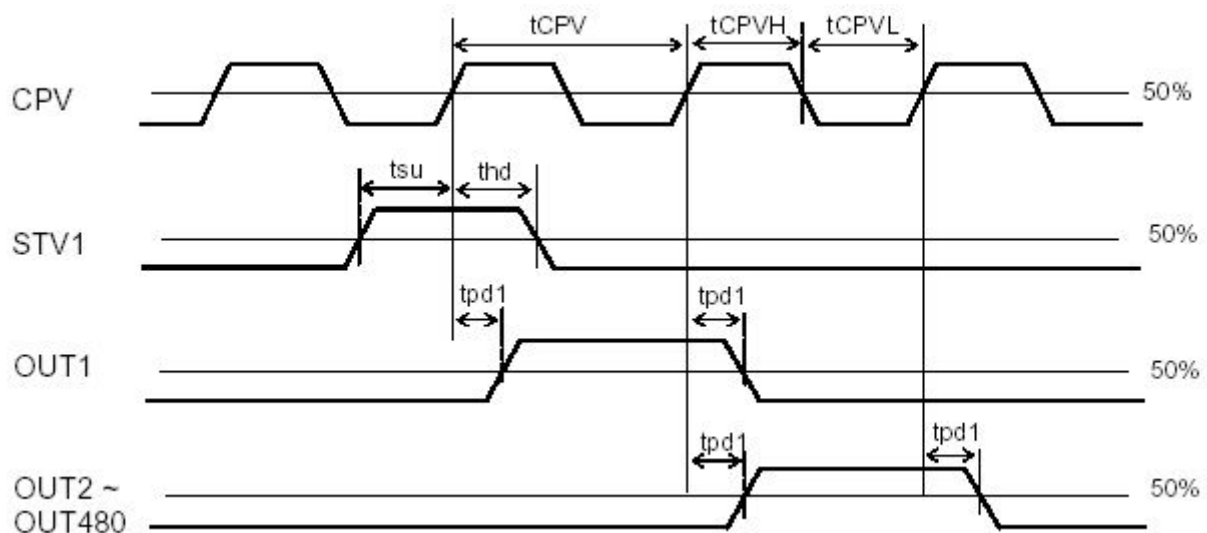

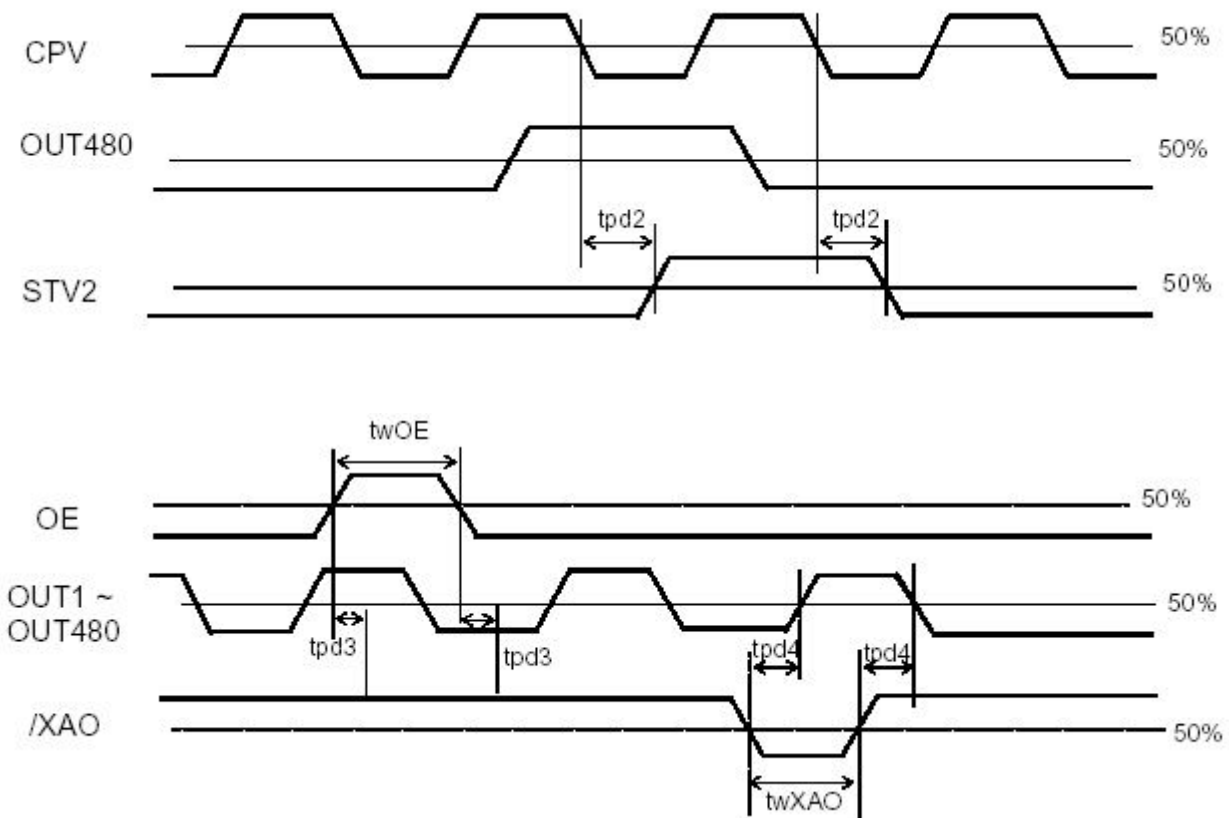

6.2 POWER ON/OFF SEQUENCE

To prevent the device from damage due to latch up, the power ON/OFF sequence shown below must be followed.

Power on sequence: $V_{cc} \rightarrow V_{GL} \rightarrow V_{GH}$

Power off sequence: $V_{GH} \rightarrow V_{GL} \rightarrow V_{cc}$

7. OPTICAL CHARACTERISTICS

7.1 TEST CONDITIONS

Item	Symbol	Value	Unit
Ambient Temperature	Ta	25±2	°C
Ambient Humidity	Ha	50±10	%RH
Supply Voltage	V _{CC}	3.3	V
Input Signal	According to typical value in "3. ELECTRICAL CHARACTERISTICS"		
Current	I _f	20	mA

Note (1) I_f means the forward current of each channel

7.2 OPTICAL SPECIFICATIONS

The relative measurement methods of optical characteristics are shown in 7.2. The following items should be measured under the test conditions described in 7.1 and stable environment shown in Note (6).

Item	Symbol	Condition	Min.	Typ.	Max.	Unit	Note		
Color Chromaticity	Red	$\theta_x=0^\circ, \theta_y=0^\circ$ Viewing Normal Angle	Typ - 0.03	0.619	Typ + 0.03		(1), (6)		
				Ry				0.364	
	Green			Gx				0.342	
				Gy				0.595	
	Blue			Bx				0.147	
				By				0.085	
	White			Wx				0.313	
				Wy				0.329	
Center Luminance of White	L _C		500	600	-	cd/m ²	(4), (6)		
Contrast Ratio	CR		500	650	-	-	(2), (6)		
Response Time	T _R		-	5	10	Ms	(3)		
	T _F		-	11	16	Ms			
White Variation	δW		-	1.25	1.4	-	(5), (6)		
Viewing Angle	Horizontal	CR 10		65	70	-	Deg.	(1), (6)	
				θ _{x-}	65	70			-
	Vertical			θ _{y+}	55	60			-
				θ _{y-}	55	60			-

Note (1) Definition of Viewing Angle (θ_x, θ_y):

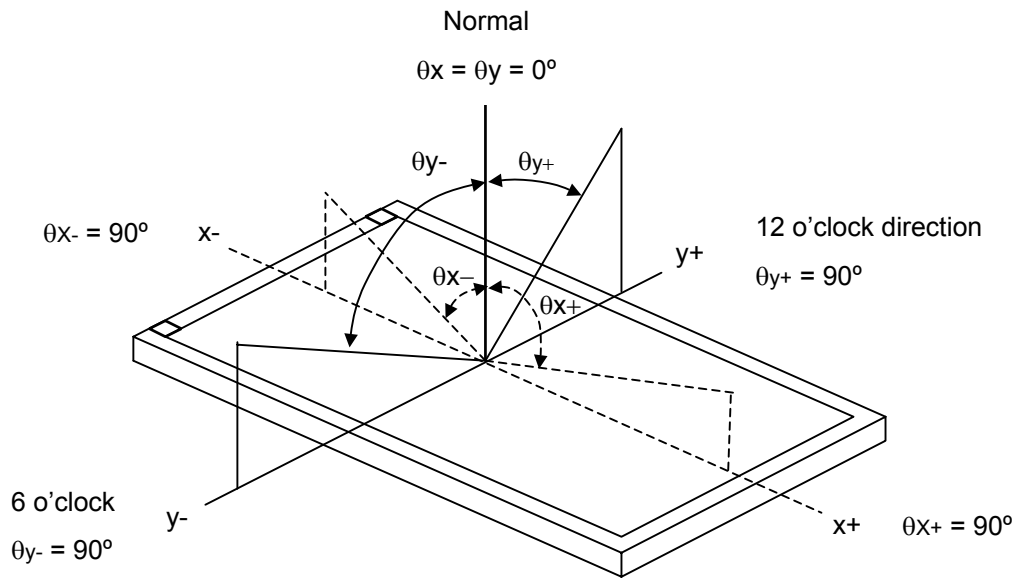

Note (2) Definition of Contrast Ratio (CR):

The contrast ratio can be calculated by the following expression.

$$\text{Contrast Ratio (CR)} = L_{63} / L_0$$

L63: Luminance of gray level 63

L 0: Luminance of gray level 0

$$\text{CR} = \text{CR} (5)$$

CR (X) is corresponding to the Contrast Ratio of the point X at Figure in Note (5).

Note (3) Definition of Response Time (T_R, T_F) and measurement method:

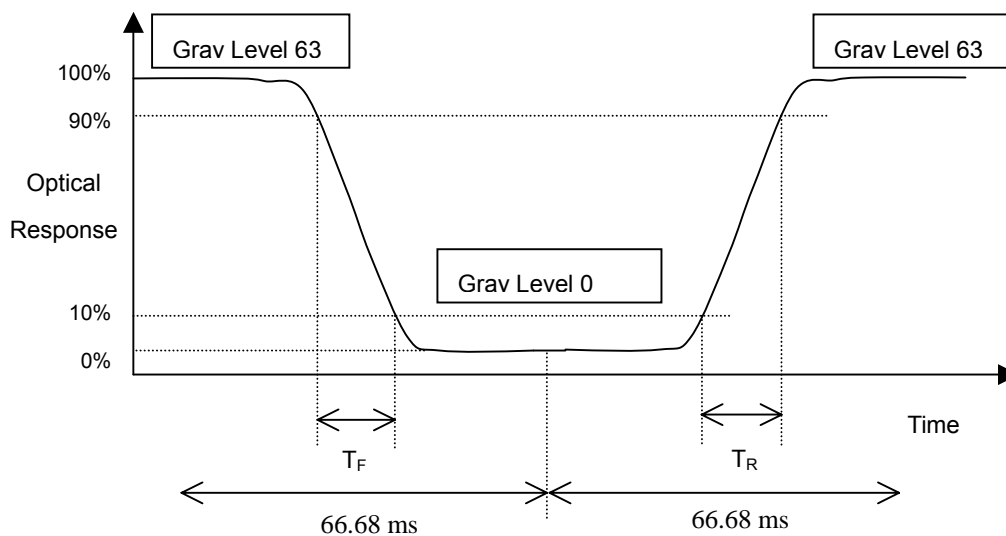

Note (4) Definition of Luminance of White (L_C):

Measure the luminance of gray level 63 at center point

$$L_C = L(5)$$

$L(x)$ is corresponding to the luminance of the point X at Figure in Note (5).

Note (5) Definition of White Variation (δW):

Measure the luminance of gray level 63 at 5 points

$$\delta W = \text{Maximum} [L(1), L(2), L(3), L(4), L(5)] / \text{Minimum} [L(1), L(2), L(3), L(4), L(5)]$$

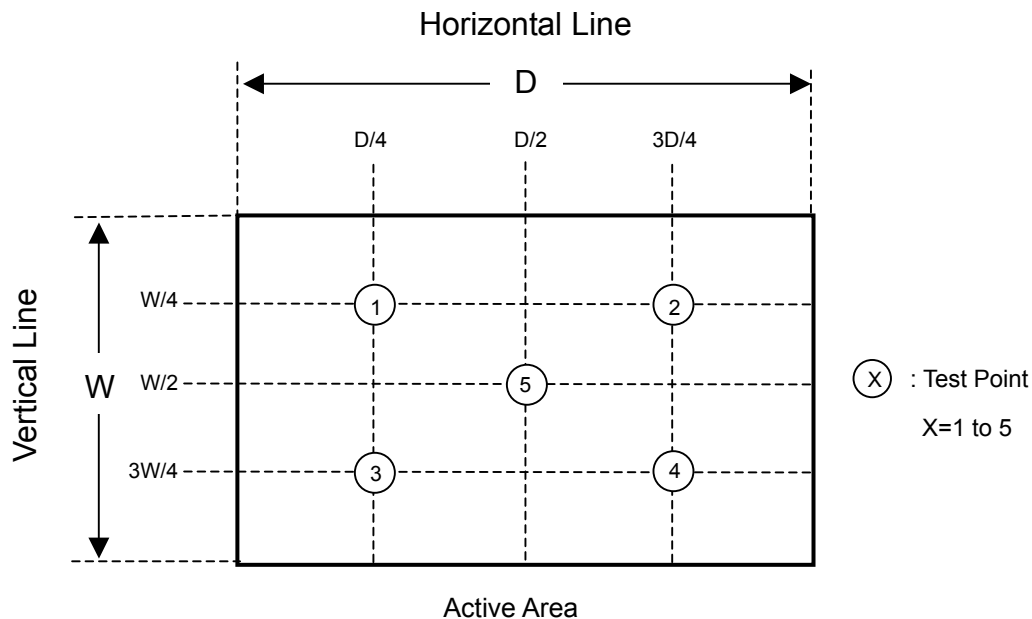

Note (6) Measurement Setup:

The LCD module should be stabilized at given temperature for 20 minutes to avoid abrupt temperature change during measuring. In order to stabilize the luminance, the measurement should be executed after lighting Backlight for 20 minutes in a windless room.

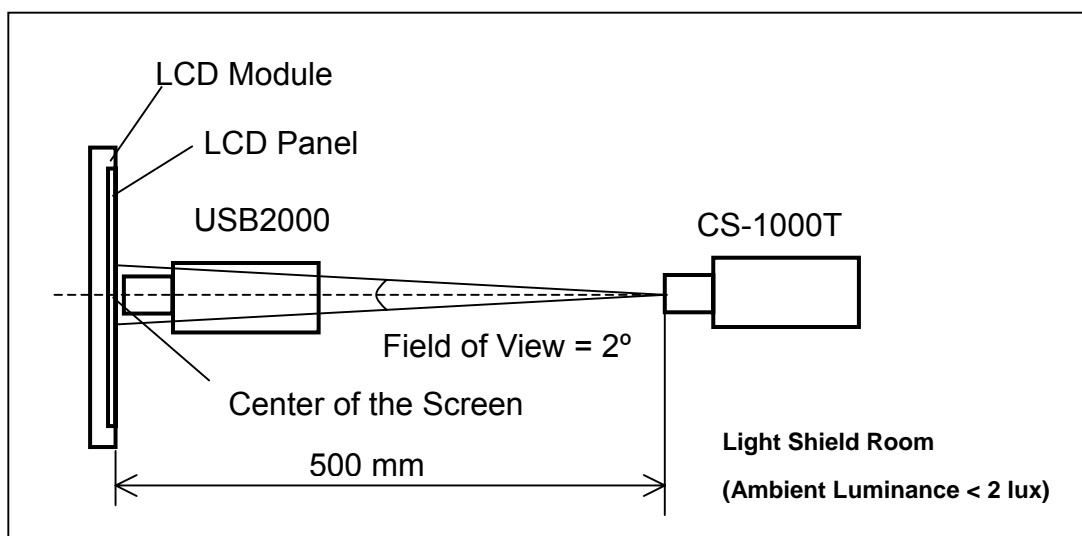

8. PACKAGING

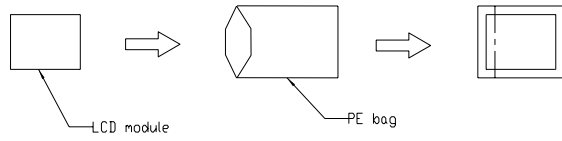

- (1) 40 LCM Modules/1 box
- (2) Carton dimensions : 435(L)x350(W)x265(H)mm
- (3) Weight : approximately 15.5 kg(40 modules per Carton).

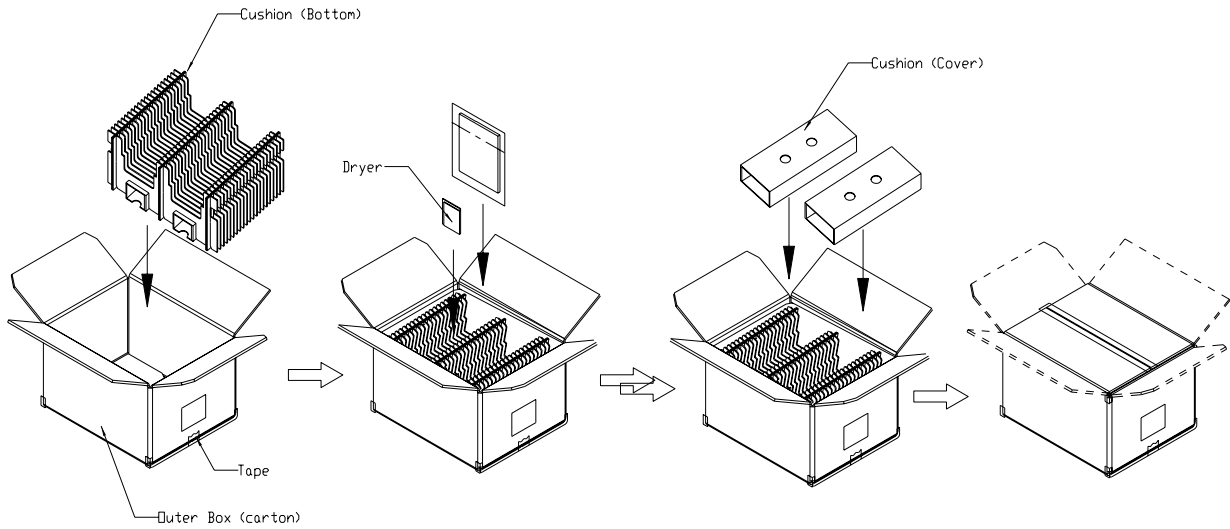

Sea and Land Transportation

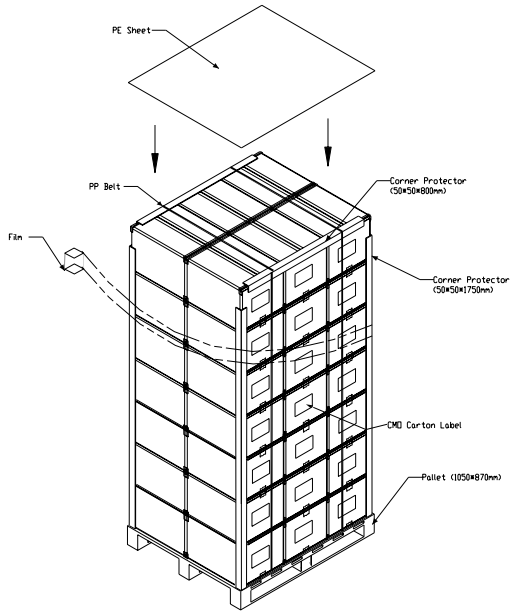

Air Transportation

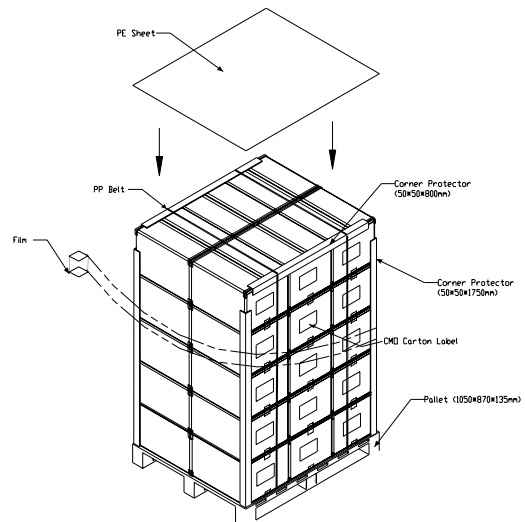

9. DEFINITION OF LABELS

9.1 CMO MODULE LABEL

The barcode nameplate is pasted on each module as illustration, and its definitions are as following explanation.

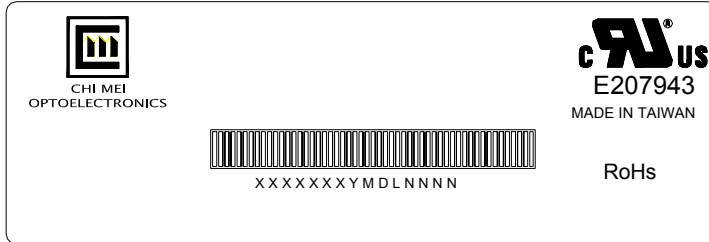

- (a) Model Name: G070Y1 - T01
- (b) Revision: Rev. XX, for example: A1, ..., C1, C2 ...etc.
- (c) Serial ID: XXXXXXXYMDXNNNN

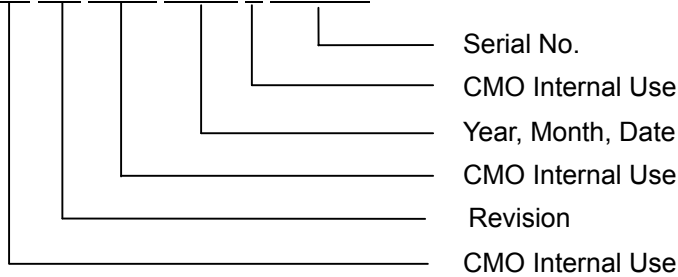

Serial ID includes the information as below:

- (a) Manufactured Date: Year: 1~9, for 2001~2009
 Month: 1~9, A~C, for Jan. ~ Dec.
 Day: 1~9, A~Y, for 1st to 31st, exclude I , O and U
- (b) Revision Code: cover all the change
 Serial No.: Manufacturing sequence of product

10. PRECAUTIONS

10.1 ASSEMBLY AND HANDLING PRECAUTIONS

- (1) Do not apply rough force such as bending or twisting to the module during assembly.
- (2) To assemble or install module into user's system can be only in clean working areas. The dust and oil may cause electrical short or worsen the polarizer.
- (3) It's not permitted to have pressure or impulse on the module because the LCD panel and Backlight will be damaged.
- (4) Always follow the correct power sequence when LCD module is connecting and operating. This can prevent damage to the CMOS LSI chips during latch-up.
- (5) Do not pull the I/F connector in or out while the module is operating.
- (6) Do not disassemble the module.
- (7) Use a soft dry cloth without chemicals for cleaning, because the surface of polarizer is very soft and easily scratched.
- (8) It is dangerous that moisture come into or contacted the LCD module, because moisture may damage LCD module when it is operating.
- (9) High temperature or humidity may reduce the performance of module. Please store LCD module within the specified storage conditions.
- (10) When ambient temperature is lower than 10°C may reduce the display quality. For example, the response time will become slowly, and the starting voltage of CCFL will be higher than room temperature.

10.2 SAFETY PRECAUTIONS

- (1) The startup voltage of Backlight is approximately 1000 Volts. It may cause electrical shock while assembling with inverter. Do not disassemble the module or insert anything into the Backlight unit.
- (2) If the liquid crystal material leaks from the panel, it should be kept away from the eyes or mouth. In case of contact with hands, skin or clothes, it has to be washed away thoroughly with soap.
- (3) After the module's end of life, it is not harmful in case of normal operation and storage.

11. APPLICATION NOTES

11.1 GAMMA CIRCUIT

AVDD	10.5
V1	10.02
V2	8.27
V3	7.79
V4	7.45
V5	6.57
V6	5.43
V7	3.37
V8	2.86
V9	2.24
V10	0.17
VCOM	4.035

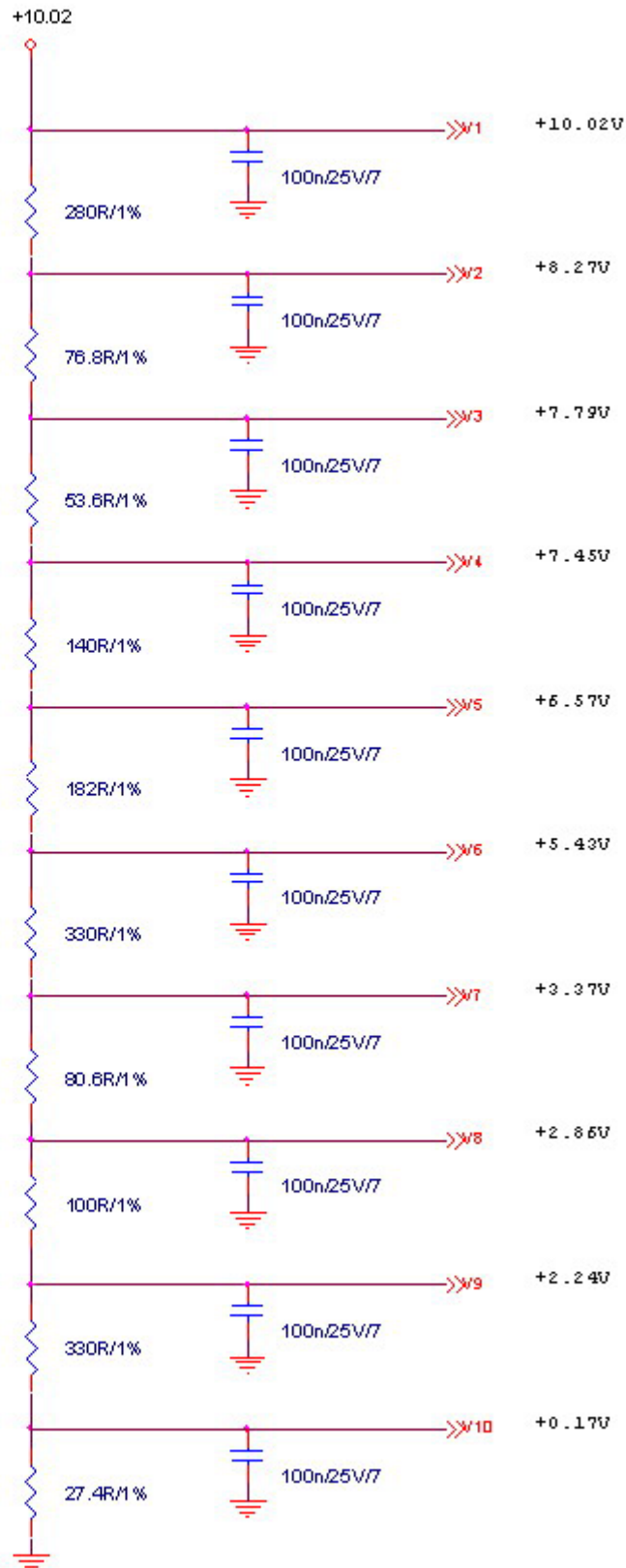

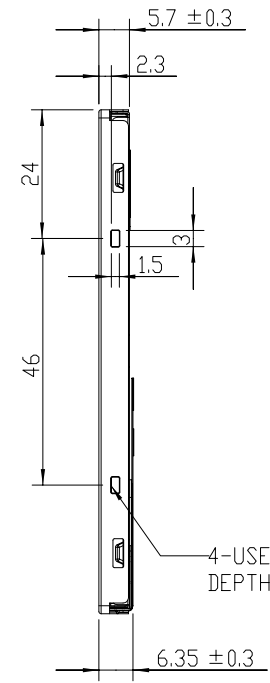
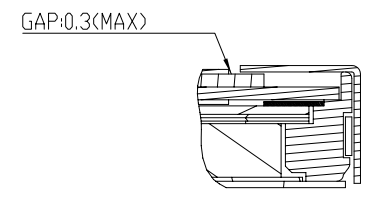
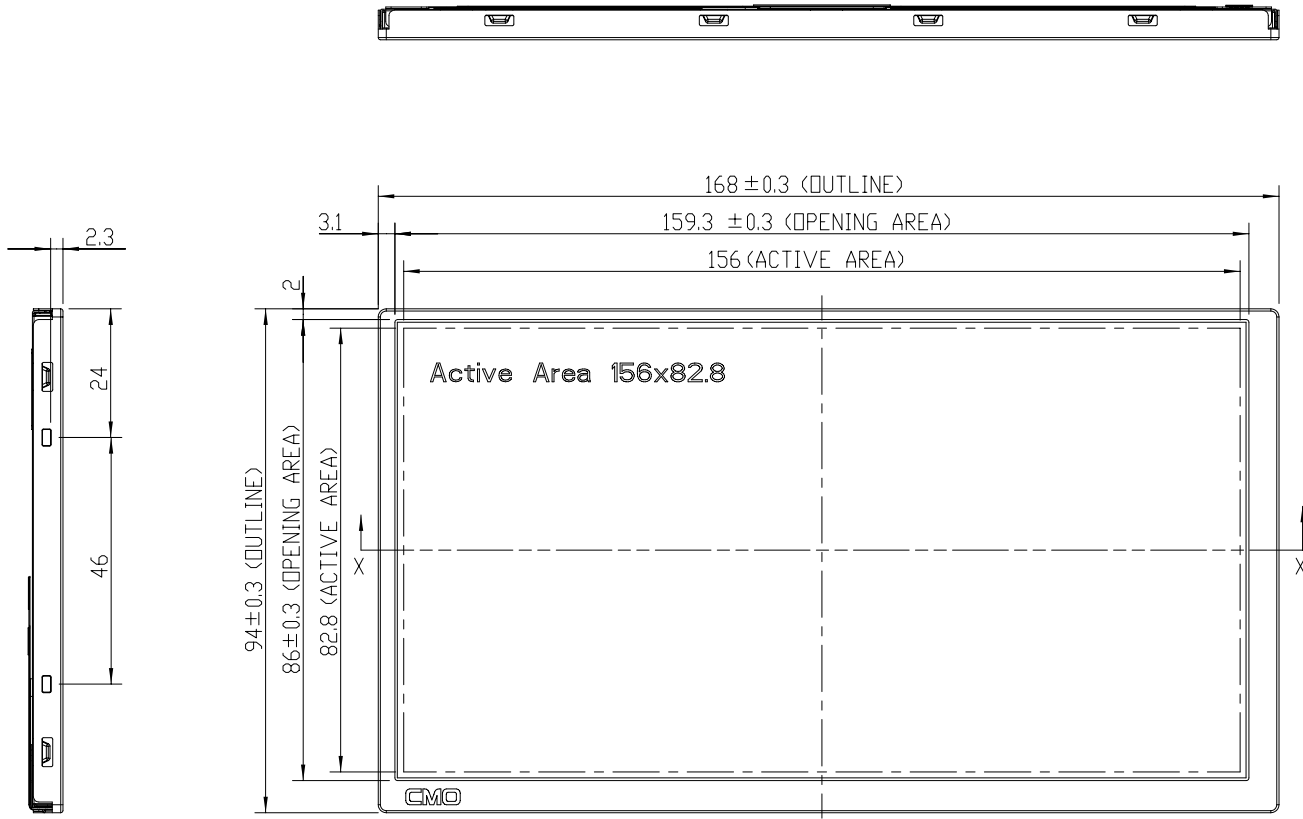

NOTES:
 1. OUTLINE TOLERANCE: ±0.3mm.
 2. LIGHT-BAR MATING CONNECTOR:
 EZ24004TX2 (4) (UNICORN)
 3. FPC MATING CONNECTOR :
 FH12-50S-0.5SH(55) (HIROSE)

TITLE	ASSY_MODULE_G070Y3-T01				2D REV.	A
					3D REV.	1.9
Approved	TIGER_CHANG	Drawing No.	G07034101A			
Checked	AIDEN_WANG	Part No.	TBD			
Drawer	AMONA_PAN	Material	TBD	Sheet	1 / 2	A3
Designer	AMONA_PAN	Date	26-Sep-2006	Scale	1:1	Unit:mm
		CHI MEI OPTOELECTRONICS CORP.		ALL RIGHTS RESERVED, COPYING FORBIDDEN.		

Mark	Description	Date	Changed_By	Approved_By	ECN No.	Remark
1			Amona			

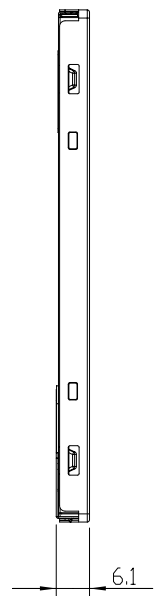
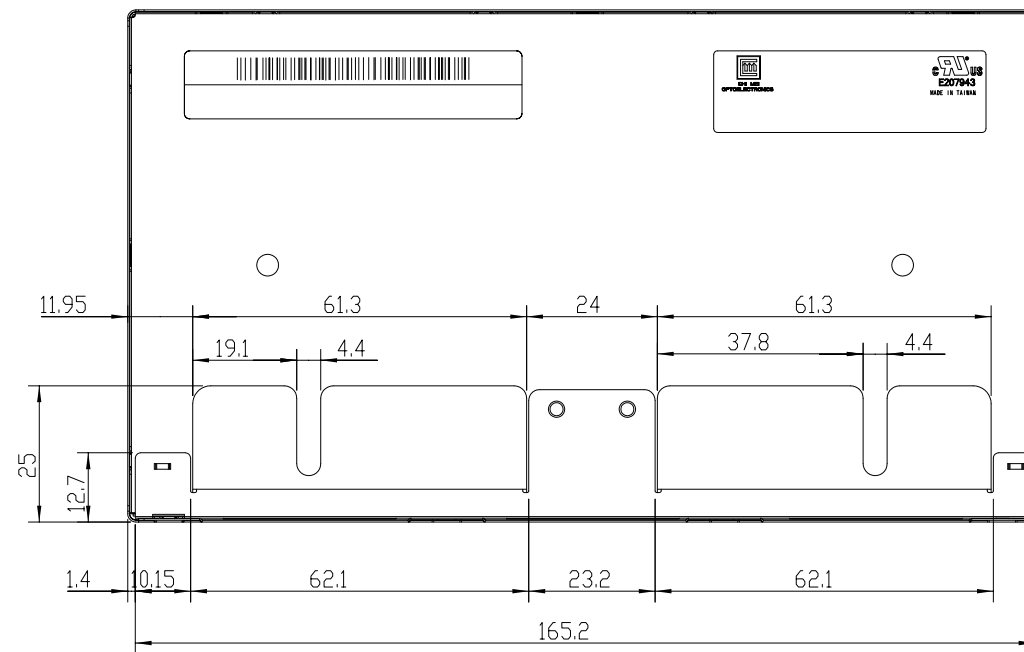
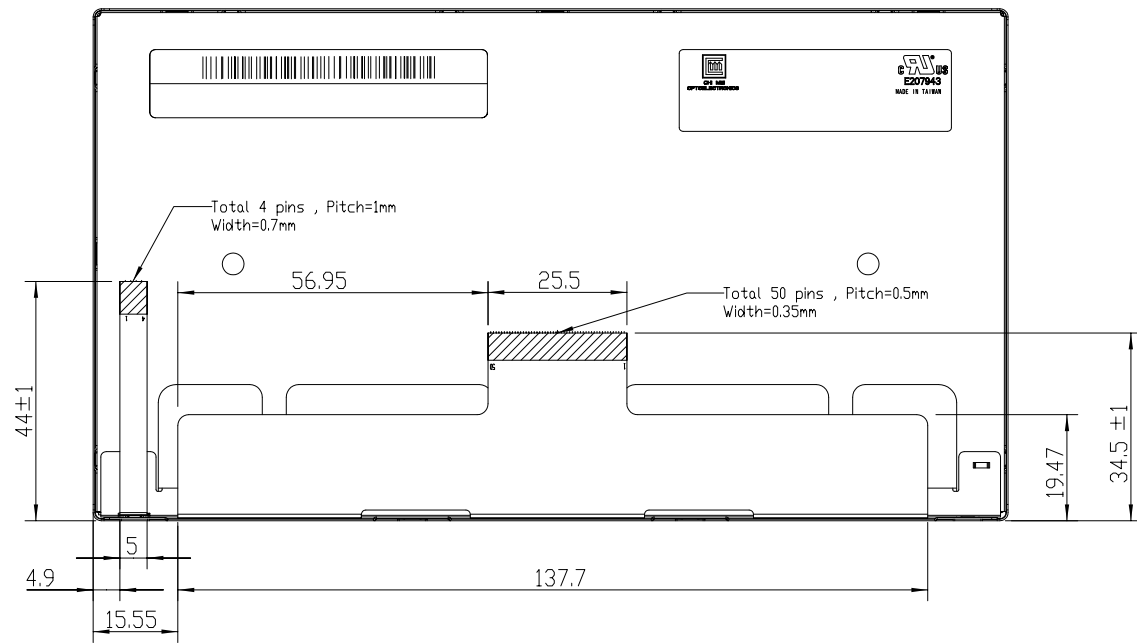

BACK VIEW WITHOUT FPC&LIGHTBAR

- NOTES:
 1. OUTLINE TOLERANCE: ±0.3mm.
 2. LIGHT-BAR MATING CONNECTOR:
 EZ24004TX2 (4) (UNICORN)
 3. FPC MATING CONNECTOR:
 FH12-50S-0.5SH(55) (HIROSE)

TITLE	ASSY_MODULE_G070Y3-T01			2D REV. A
				3D REV. 1.9
Approved	TIGER_CHANG	Drawing No.	G07034101A	
Checked	AIDEN_WANG	Part No.	TBD	
Drawer	AMONA_PAN	Material	TBD	Sheet 2 / 2 A2
Designer	AMONA_PAN	Date	22-Jun-2007	Scale 1:1 Unit:mm
		CHI MEI OPTOELECTRONICS CORP. ALL RIGHTS RESERVED, COPYING FORBIDDEN.		

Mark	Description	Date	Changed_By	Approved_By	ECN No.	Remark
1						
2						
3						
4						
5						
6						
7						
8						