

To : _____

Specification of FUJITSU TFT-LCD module

FLC43XWC6V-02

(Preliminary)

Approval
Date :
By :

This Product is designed, developed and manufactured as contemplated for general use, including without limitation, general office use, personal use, household use, and ordinary industrial use, but is not designed, developed and manufactured as contemplated for use accompanying fatal risks or dangers that, unless extremely high safety is secured, could lead directly to death, personal injury, severe physical damage or other loss (hereinafter "High Safety Required Use"), including without limitation, nuclear reaction control in nuclear facility, aircraft flight control, air traffic control, mass transport control, medical life support system, missile launch control in weapon system. If customer's product possibly falls under the category of High Safety Required Use, please consult with our sales representatives in charge before such use. In addition, Fujitsu shall not be liable against the Customer and/or any third party for any claims or damages arising in connection with the High Safety Required Use of the Product without permission.

Specification No. : Tech Bes LCD-00087

Issue Date : Aug. 10, 2001

Issued by :



T. Naka

Director

LCD Design Dep.

LCD Technology Div.

LCD Group

FUJITSU LIMITED

TABLE OF CONTENTS

A

1.APPLICATIONS..... 3

2.PRODUCT NAME AND MODEL NUMBER

2-1.Product Name 3

2-2.Model Name 3

3.OVERVIEW..... 3

4.CONFIGURATION..... 3

5.MECHANICAL SPECIFICATIONS..... 4

B

6.ABSOLUTE MAXIMUM RATINGS..... 5

7.RECOMMENDED OPERATING CONDITIONS 5

8.ELECTRICAL SPECIFICATIONS 6

9.OPTICAL SPECIFICATIONS 8

10.INTERFACE SPECIFICATIONS

10-1.Signal descriptions 12

10-2.Color Data Assignment 13

10-3.Input Signal Timing 14

10-4.Correspondence between Data and Display Position 16

10-5.Power Supply Sequence 16

C

11.BACKLIGHT SPECIFICATIONS

11-1.Pin Configuration for Backlight 17

11-2.CCFL 17

11-3.Life 17

11-4.Lamp Assembly Set (for Replacement) 17

12.APPEARANCE SPECIFICATIONS

D

12-1.Zone 18

12-2.Bright Spot..... 18

12-3.Test Condition..... 18

12-4.Standard 18

13.ENVIRONMENTAL SPECIFICATIONS 20

14.INDICATIONS..... 21

15.PACKAGING

15-1.Packaging Specifications 21

15-2.Packaging Method 21

16.WARRANTY..... 26

17.PRECAUTIONS 26

18.PRECAUTIONS FOR USE..... 29

19.MISCELLANEOUS..... 29

A

B

C

D

E

DOCUMENT CONTROL SECTION

DATE

F

FLC43XWC6V-02

Tech Bes LCD-00087

CUST.

EDIT DATE DESIG. CHECK APPR. DESCRIPTION

FUJITSU LIMITED

02111111

2 /

DESIG.

CHECK

APPR.

1. APPLICATIONS

This specification is applied to the 17.0 in. XGA-WIDE supported TFT-LCD module.

2. PRODUCT NAME AND MODEL NUMBER

2-1. Product Name : LCD Module

2-2. Model Name : FLC43XWC6V-02

3. OVERVIEW

This LCD module has a TFT active matrix type liquid crystal panel 1280×768 pixels, and diagonal size of 43cm (17.0-inch). This module supports 1280×768 XGA-WIDE mode (Non-interlace).

This LCD has a digital RGB interface and can display 262,144 colors.

Timing control signal is “Data enable signal : ENAB” only. (Data enable mode)

Even and odd data are transmitted at the same timing in the interface, so data lines are 36. (R, G, B each 6 bit ×2) The signal level of this interface is +3.3V CMOS level or 5V TTL level.

The power supply of this LCD module is +5v DC single.

4. CONFIGURATION

This LCD module consists of a LCD panel, LCD driving circuit, control circuit, interface circuit and backlight unit.

The LCD panel is active matrix TFT type and Fujitsu’s unique MVA (Multi-domain Vertical Alignment) liquid crystal technology is adopted in it. The LCD driving circuit is integrated in IC chips, which are bonded on plastic wiring film (hereinafter TAB driver-IC), and the output terminals of the IC chips are connected to the LCD panel. The control circuit and the interface circuit are mounted on three kinds of printed circuit board (hereinafter PCB) and the input of the TAB driver-ICs are connected to the PCBs.

With such circuit construction, the image data received by the interface circuit is forwarded to the control circuit and the control circuit modulates the image data to LCD driving signals. The TAB driver ICs buffer the LCD driving signals and output driving voltages to the LCD panel.

These LCD parts such as the LCD panel, the TAB-ICs and the PCBs are assembled together with the backlight module in a plastic case and a metal frame.

Fig.4-1 shows a block diagram of this LCD module.

DOCUMENT CONTROL SECTION

DATE

						FLC43XWC6V-02	
						Tech Bes LCD-00087	
						CUST.	
EDIT	DATE	DESIG.	CHECK	APPR.	DESCRIPTION		
DESIG.			CHECK		FUJITSU LIMITED		
						3 /	

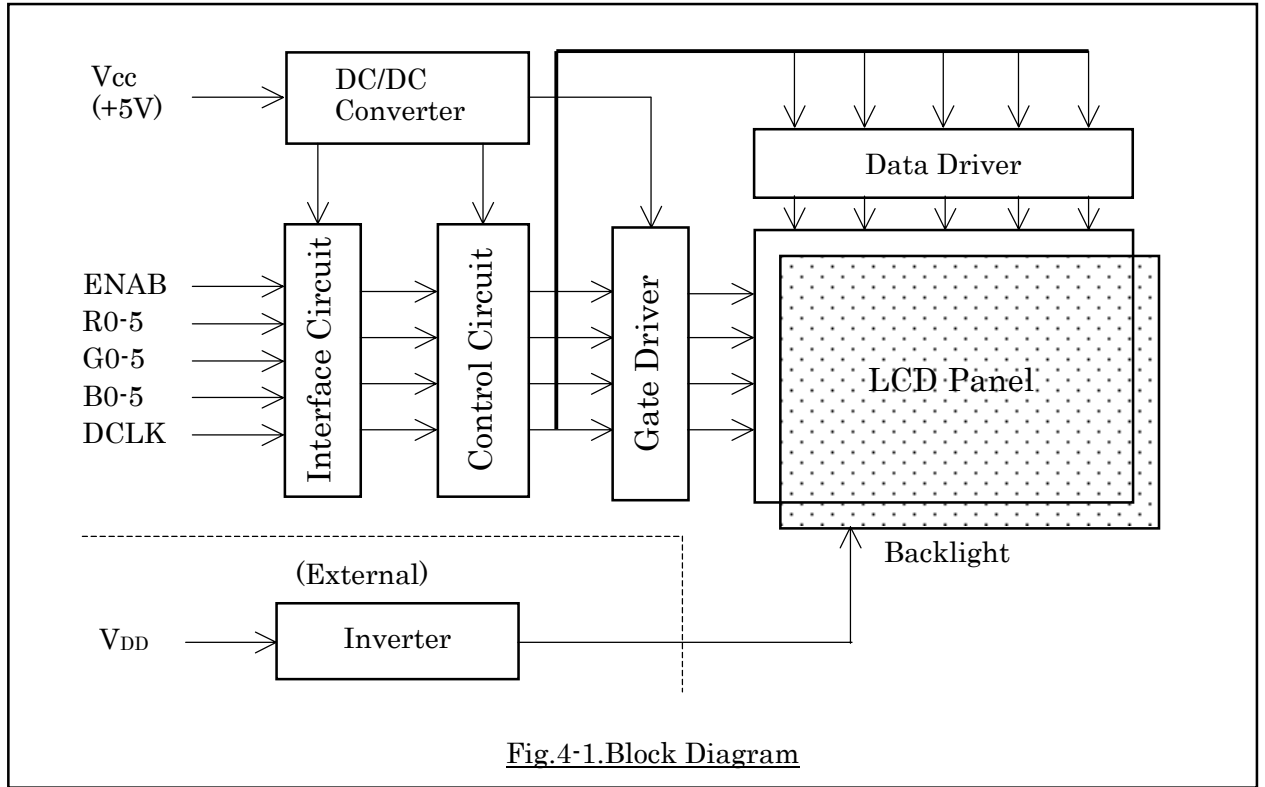

Fig.4-1. Block Diagram

5. MECHANICAL SPECIFICATIONS

Table 5-1 shows the mechanical specifications of this LCD module.

Table 5-1. Mechanical Specifications

Item	Specifications	Unit	Remark
Dimensions	413.8×263.5×19.4(TYP.) (Excluding I/F Connector and fixing parts)	mm	Edge type backlight is used. (φ2.6 CCFL×4)
Display Resolution	(1280×3) ×768	—	
Display Dot Area	369.6×221.76	mm	Outward Appearance is shown at page 30 and 31.
Dot Pitch	(0.09625×3) ×0.28875	mm	
Aspect Ratio	1 : 1	—	
Weight	2,000 max	g	
FG-SG	Short circuit	—	

DOCUMENT CONTROL SECTION

						FLC43XWC6V-02	
						Tech Bes LCD-00087	
						CUST.	
EDIT	DATE	DESIG.	CHECK	APPR.	DESCRIPTION	FUJITSU LIMITED	
DESIG.			CHECK		APPR.	4 /	

6. ABSOLUTE MAXIMUM RATINGS

Table 6-1 shows the absolute maximum rating of this LCD module.

Table 6-1. Absolute Maximum Ratings

Item	Symbol	Condition	MIN.	TYP.	MAX.	Unit
Supply Voltage	V _{CC}	Ta=25°C	-0.3	—	6.0	V
Input Voltage	V _{IN}	Ta=25°C	-0.3	—	V _{CC} +0.3	V

7. RECOMMENDED OPERATING CONDITIONS

Table 7-1 shows the recommended operating conditions of this LCD module.

Table 7-1. Recommended Operating Conditions

Item	Symbol	MIN.	TYP.	MAX.	Unit
Supply Voltage (Logic)	V _{CC}	4.75	5.0	5.25	V
Ripple Voltage	V _{CC} V _{RP}	—	—	100	mV

DOCUMENT CONTROL SECTION

DATE

						FLC43XWC6V-02	
						Tech Bes LCD-00087	
						CUST.	
EDIT	DATE	DESIG.	CHECK	APPR.	DESCRIPTION		
DESIG.			CHECK		FUJITSU LIMITED		
						5 /	

8. ELECTRICAL SPECIFICATIONS

Table 8-1 shows the electrical specifications of this LCD module.

Table 8-1. Electrical Specifications

Item	Symbol	Condition	MIN.	TYP.	MAX.	Unit	Remark
Supply Current	I _{CC}	V _{CC} =+5.0±0.25V V _{SS} =0V	—	380	800	mA	*1
“H” Level Logic Input Voltage	V _{IH}	DCLK=32.505MHz	2.3	—	V _{CC}	V	
“L” Level Logic Input Voltage	V _{IL}		V _{SS}	—	0.9	V	
Supply Rush Current	I _{SCC}		—	5.5	7	A	*2
Supply Rush Current Duration (1A excess)	T _{SCC}		—	0.4	0.15	ms	
BACK LIGHT CCFL Turn on Voltage	V _S	f _L =50kHz, T _a =25°C	—	1230	1600	V _{rms}	*4
		f _L =50kHz, T _a =0°C	—	—	1600		*4
Lighting Voltage	V _L	f _L =50kHz I _L =7mA	590	630	670	V _{rms}	*4
Lighting Frequency	f _L	V _L =580V _{rms}	40	50	60	kHz	
*3 Tube Current	I _L	f _L =50kHz V _L =580V _{rms}	9.5	10.5	11.0	mA	*4

(*1) Typical current value is measured when color bar pattern is displayed at V_{CC}=5.0V.
Maximum current value is measured when 55/63 and 63/63 gray scale pattern every 2 pixel is displayed at V_{CC}=4.75V.
Without rush current.

(*2) These items prescribe the rush current for starting internal DC/DC.
Charging current to capacitors of V_{CC} is not prescribed.

(*3) Backlight specifications are valid when using a suitable inverter such as the “CA05951-3894” of Fujitsu Limited.

(*4) Tube current (I_L) shows the value of the current that is consumed at one lamp.
This LCD module has 4 lamps. Each 2 lamps are placed at upper and lower side of the display.
2 lamps are connected in parallel. Each low voltage terminals are bound into 1 line cable, which connected to the backlight connector.

DOCUMENT CONTROL SECTION

DATE

						FLC43XWC6V-02	
						Tech Bes LCD-00087	
						CUST.	
EDIT	DATE	DESIG.	CHECK	APPR.	DESCRIPTION		
DESIG.			CHECK		FUJITSU LIMITED		
						6 /	

Note 1) Measurement Circuit

Based on Fig.8-1.

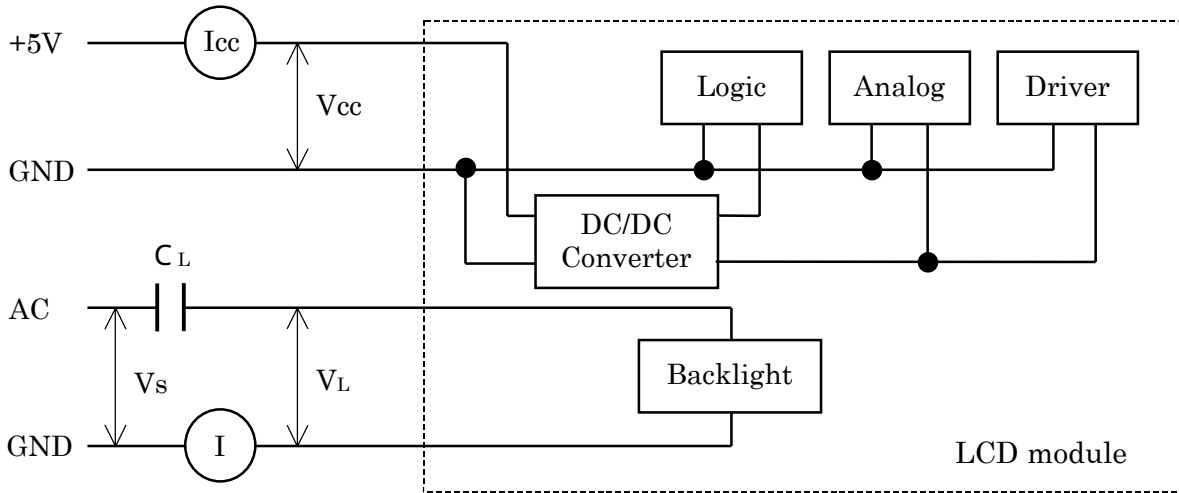

Fig.8-1. Measurement Circuit

Note 2) Equivalent Circuit

Based on Fig.8-2 (a), (b).

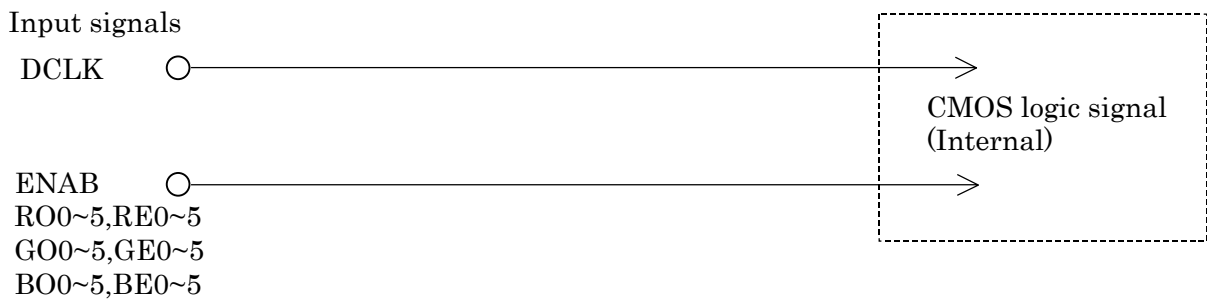
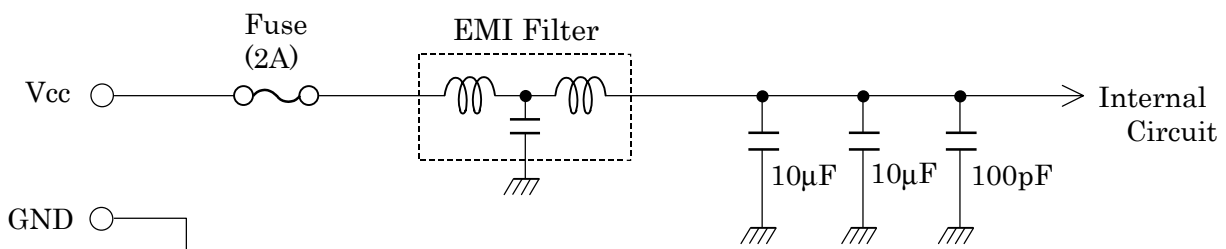

Fig.8-2 (a) Equivalent Circuit of Logic Signal Input



FuseKAB2402202NA (Matsuo Electric CO., LTD.)
EMI FilterSGM20C1E332-2A(Sumitomo Metals)

Fig.8-2 (b) Equivalent Circuit of Power Supply

DOCUMENT CONTROL SECTION

DATE

						FLC43XWC6V-02	
						Tech Bes LCD-00087	
						CUST.	
EDIT	DATE	DESIG.	CHECK	APPR.	DESCRIPTION	FUJITSU LIMITED	
DESIG.			CHECK		APPR.	7 /	

9. OPTICAL SPECIFICATIONS

Table 9-1 shows the optical specifications of this LCD module.

Table 9-1. Optical Specifications

Ta=25°C

Item		Symbol	Condition		Specifications			Unit	Remark	
					MIN.	TYP.	MAX			Note
Visual Angle	Horizontal	$\theta_{L,R}$	CR \geq 10	$\theta_{U,D}=0^\circ$	80	—	—	deg		(1)(2)
	Vertical	$\theta_{U,D}$		$\theta_{L,R}=0^\circ$	80	—	—	deg		(3)(5)
Contrast Ratio		CR	$\theta_{L,R,U,D}=0^\circ$		210	500	—	—	White/Black	(1)(2) (3)(5)
Response Time(ON) (B W)		t_{on}	$\theta_{L,R,U,D}=0^\circ$	Ta=25°C	—	15	30	ms		(1)
				Ta=0°C	—	50	100	ms		(4) (5)
Response Time(OFF) (W B)		t_{off}	$\theta_{L,R,U,D}=0^\circ$	Ta=25°C	—	10	25	ms		
				Ta=0°C	—	50	100	ms		
Brightness		I	$\theta_{L,R,U,D}=0^\circ$ V _{CC} =5V, I _L =7mA (at maximum brightness)		(340)	400	—	cd/m ²	White *1	(1)(5)
Brightness Uniformity		ΔI			70	—	—	%		(1)(5) (7)
Chromaticity	W	X			T.B.D.	T.B.D.	T.B.D.	—		
		Y	T.B.D.	T.B.D.	T.B.D.	—	(5)			
	R	(x, y)	Red	T.B.D.						
	G		Green	T.B.D.						
	B		White	T.B.D.						
LCD Panel Type					TFT Color					
Display Mode					Normally Black VA					
Wide Viewing Angle Technology					MVA					
Optimum Viewing Angle					— (symmetry)					(6)
Display Color					262,144 (6-bit color)					
Color of non-display area					Black					
Surface Treatment					Anti-glare (Haze value:25%, 2H)					

(*1) Value at 20~30 minutes after lighting on.

(Note) •CS-1000 (MINOLTA Co., Ltd.) , BM-5A(Topcon) or equivalent luminance colorimeter should be used for the measurement.

Field=2°, L=500mm

•The specified value of viewing angle, contrast, brightness, brightness uniformity and chromaticity are under the dark room condition (1lux or less).

DOCUMENT CONTROL SECTION

DATE

					FLC43XWC6V-02				
					Tech Bes LCD-00087				
					CUST.				
EDIT	DATE	DESIG.	CHECK	APPR.	DESCRIPTION				
DESIG.			CHECK		FUJITSU LIMITED				
					8 /				

Note 1) Definition of Viewing Angle (1)

Based on Fig.9-2.

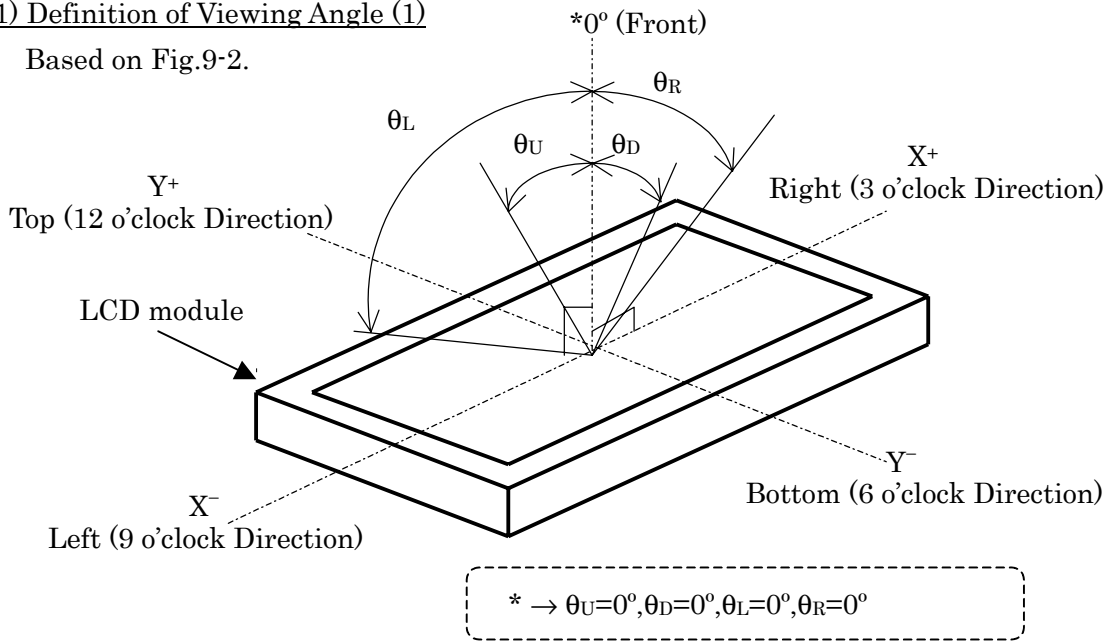

Fig.9-2. Definition of Viewing Angle (1)

Note 2) Definition of Viewing Angle (2)

Based on Fig.9-3.

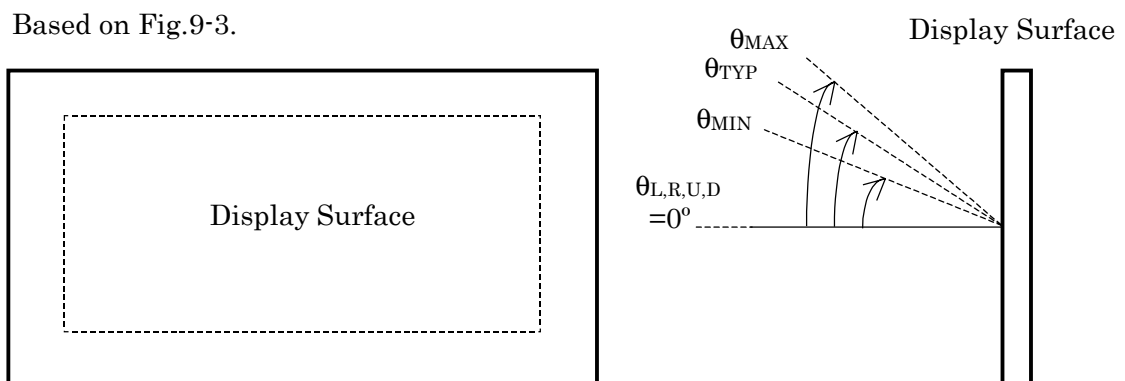

Fig.9-3. Definition of Viewing Angle (2)

Note 3) Definition of Contrast Ratio (CR)

Determined by Formula (1) based on Fig.9-4.Voltage-Brightness Characteristics.

$$= \frac{L_W \text{ (Brightness at white)}}{L_B \text{ (Brightness at black)}} \text{ ----- (1)}$$

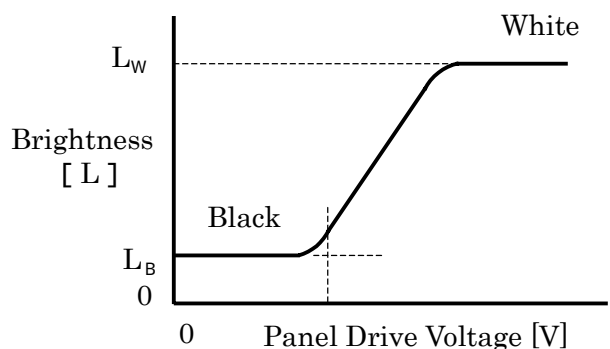

Fig.9-4. Voltage-Brightness Characteristics

DOCUMENT CONTROL SECTION
DATE

						FLC43XWC6V-02	
						Tech Bes LCD-00087	
						CUST.	
EDIT	DATE	DESIG.	CHECK	APPR.	DESCRIPTION	FUJITSU LIMITED	
DESIG.			CHECK		APPR.	9 /	

Note 6) Definition of Optimum Viewing Angle

Based on Fig.9-7.

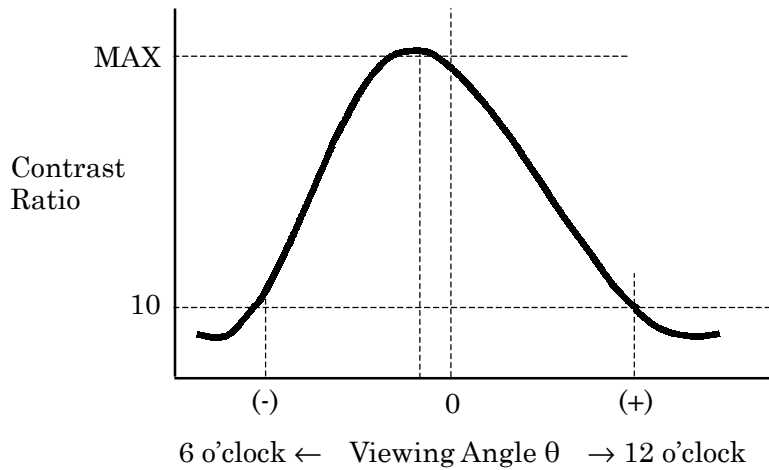

Fig.9-7. Definition of Viewing Angle

Note 7) Definition of Brightness Uniformity

Brightness uniformity is defined by the following formula.

Brightness (I1~I9) are measured at the following 9 points (① ~ ⑨) on the display area shown in Fig.9-8.

$$\text{Brightness Uniformity } (\Delta L) = \frac{|\text{Min. In}|}{|\text{Max. In}|} \times 100 (\%), n=1 \text{ to } 9$$

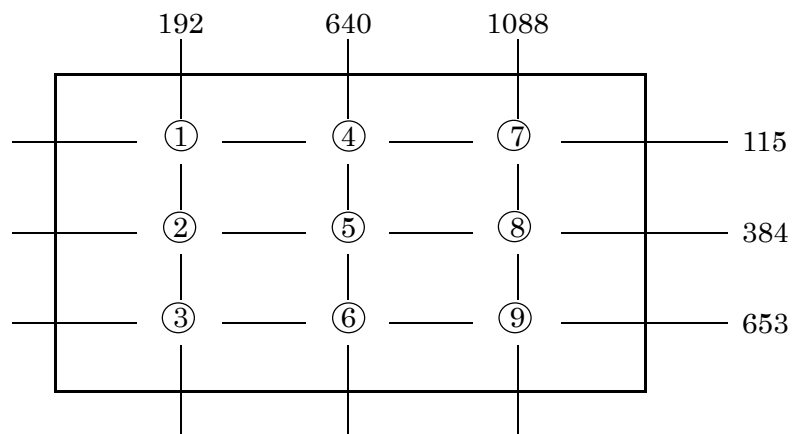

Note) Each measurement point (① ~ ⑨) defines the center spot of Brightness Meter view. The tolerance of measurement position is ±5mm.

Fig.9-8. Measurement Points

DOCUMENT CONTROL SECTION

DATE

						FLC43XWC6V-02	
						Tech Bes LCD-00087	
						CUST.	
EDIT	DATE	DESIG.	CHECK	APPR.	DESCRIPTION		
DESIG.			CHECK		APPR.		
FUJITSU LIMITED						11 /	

10. INTERFACE SPECIFICATIONS

10-1. Signal descriptions

Table 10-1 shows the description and configuration of Interface signals (CN1).

Table 10-1. Interface signals (CN1)

Pin No.	Symbol	I/O	Function	Pin No.	Symbol	I/O	Function
1	GND	—	Ground	31	GO1	I	Green odd data 1
2	RE0	I	Red even data 0	32	GO2	I	Green odd data 2
3	RE1	I	Red even data 1	33	GO3	I	Green odd data 3
4	RE2	I	Red even data 2	34	GO4	I	Green odd data 4
5	RE3	I	Red even data 3	35	GO5	I	Green odd data 5
6	RE4	I	Red even data 4	36	GND	—	Ground
7	RE5	I	Red even data 5	37	BO0	I	Blue odd data 0
8	GND	—	Ground	38	BO1	I	Blue odd data 1
9	GE0	I	Green even data 0	39	BO2	I	Blue odd data 2
10	GE1	I	Green even data 1	40	BO3	I	Blue odd data 3
11	GE2	I	Green even data 2	41	BO4	I	Blue odd data 4
12	GE3	I	Green even data 3	42	BO5	I	Blue odd data 5
13	GE4	I	Green even data 4	43	GND	—	Ground
14	GE5	I	Green even data 5	44	GND	—	Ground
15	GND	—	Ground	45	GND	—	Ground
16	BE0	I	Blue even data 0	46	ENAB	I	Data enable signal
17	BE1	I	Blue even data 1	47	GND	—	Ground
18	BE2	I	Blue even data 2	48	GND	—	Ground
19	BE3	I	Blue even data 3	49	DCLK	I	Dot clock signal
20	BE4	I	Blue even data 4	50	GND	—	Ground
21	BE5	I	Blue even data 5	51	GND	—	Ground
22	GND	—	Ground	52	SS	—	SS function ON/OFF (*1)
23	RO0	I	Red odd data 0	53	GND	—	Ground
24	RO1	I	Red odd data 1	54	GND	—	Ground
25	RO2	I	Red odd data 2	55	GND	—	Ground
26	RO3	I	Red odd data 3	56	GND	—	Ground
27	RO4	I	Red odd data 4	57	VDD	—	+5V Power supply
28	RO5	I	Red odd data 5	58	VDD	—	+5V Power supply
29	GND	—	Ground	59	VDD	—	+5V Power supply
30	GO0	I	Green odd data 0	60	VDD	—	+5V Power supply

(*1) SS (Spread Spectrum):SS function is ON when signal level is high or N.C..(generally set up N.C.)
 SS function is OFF when signal level is low.

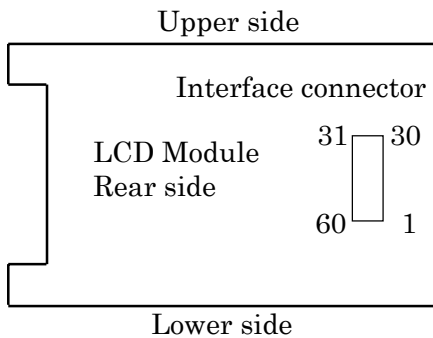

Connector : 52760-0600 (Molex)
 User's connector : 53475-0600 (Molex)

DOCUMENT CONTROL SECTION

DATE

						FLC43XWC6V-02	
						Tech Bes LCD-00087	
						CUST.	
EDIT	DATE	DESIG.	CHECK	APPR.	DESCRIPTION	FUJITSU LIMITED	
DESIG.			CHECK		APPR.	12/	

10-3. Input Signal Timing

Table 10-3 and Fig.10-3 shows the input signal timing.

Table 10-3. Timing Characteristics

(T=0~50°C, Vcc=5±0.25V)

Item		Symbol	Min.	Typ.	Max.	Unit	Remark	
DCLK signal (Clock)	Period	Tc	30.764	30.764	40.000	ns	fc=1/Tc *1	
	Frequency	fc	25.000	32.505	32.505	MHz		
	Duty	Tch/Tc	45	50	55	%		
	High time	TclkH	5.0	—	—	ns		
	Low time	TclkL	5.0	—	—	ns		
	Rise time	Telkr	—	—	5.0	ns		
	Fall time	Telkf	—	—	5.0	ns		
DCLK-Data Timing	Setup time	Tset	4.5	—	—	ns	40MHz	
	Hold time	Thold	6.5	—	—	ns	40MHz	
Data-ENAB timing	Horizontal	Period	Th	672	672	1566	DCLK	fh=1/Th
		Frequency	fh	46.6	48.3	48.3	kHz	
		Display period	Thd	640	640	640	DCLK	*2,3
	Vertical	Period	Tv	776	806	806	Th	16.67ms
		Frequency	fv	60	60	60	Hz	
		Display period	Tvd	768	768	768	Th	*2,3
Data-ENAB timing		Tdn	0	0	0	DCLK	*4	

*1) DCLK signal input must be valid while power supply is applied.

*2) Display position is specified by the ENAB signal.

- Horizontal display position is specified by the rise of ENAB signal. The data of a horizontal line, which is latched by the falling edge of 1st DCLK right after the rise of ENAB, is displayed on the left edge of the screen.
- Vertical display position is specified by the rise of ENAB after a “Low” level period equivalent to eight times of horizontal period. The 1st data corresponding to one horizontal line after the rise of ENAB is displayed at the top line of screen.

*3) If a period of ENAB “High” is less than 640 DCLK or less than 768 lines, the rest of the screen displays black.

*4) The display position does not fit to the screen if the ENAB period and the effective data period do not synchronize with each other.

DOCUMENT CONTROL SECTION

DATE

						FLC43XWC6V-02	
						Tech Bes LCD-00087	
						CUST.	
EDIT	DATE	DESIG.	CHECK	APPR.	DESCRIPTION		
DESIG.			CHECK	APPR.	FUJITSU LIMITED		
						14/	

A

DCLK

ENAB

RO5-5, RE5-0
GO5-0, GE5-0
BO5-0, BE5-0

B

RO5-0, RE5-0
GO5-0, GE5-0
BO5-0, BE5-0

ENAB

C

RO5-0, RE5-0
GO5-0, GE5-0
BO5-0, BE5-0

ENAB

D

DCLK

RO5-0, RE5-0
GO5-0, GE5-0
BO5-0, BE5-0

ENAB

E

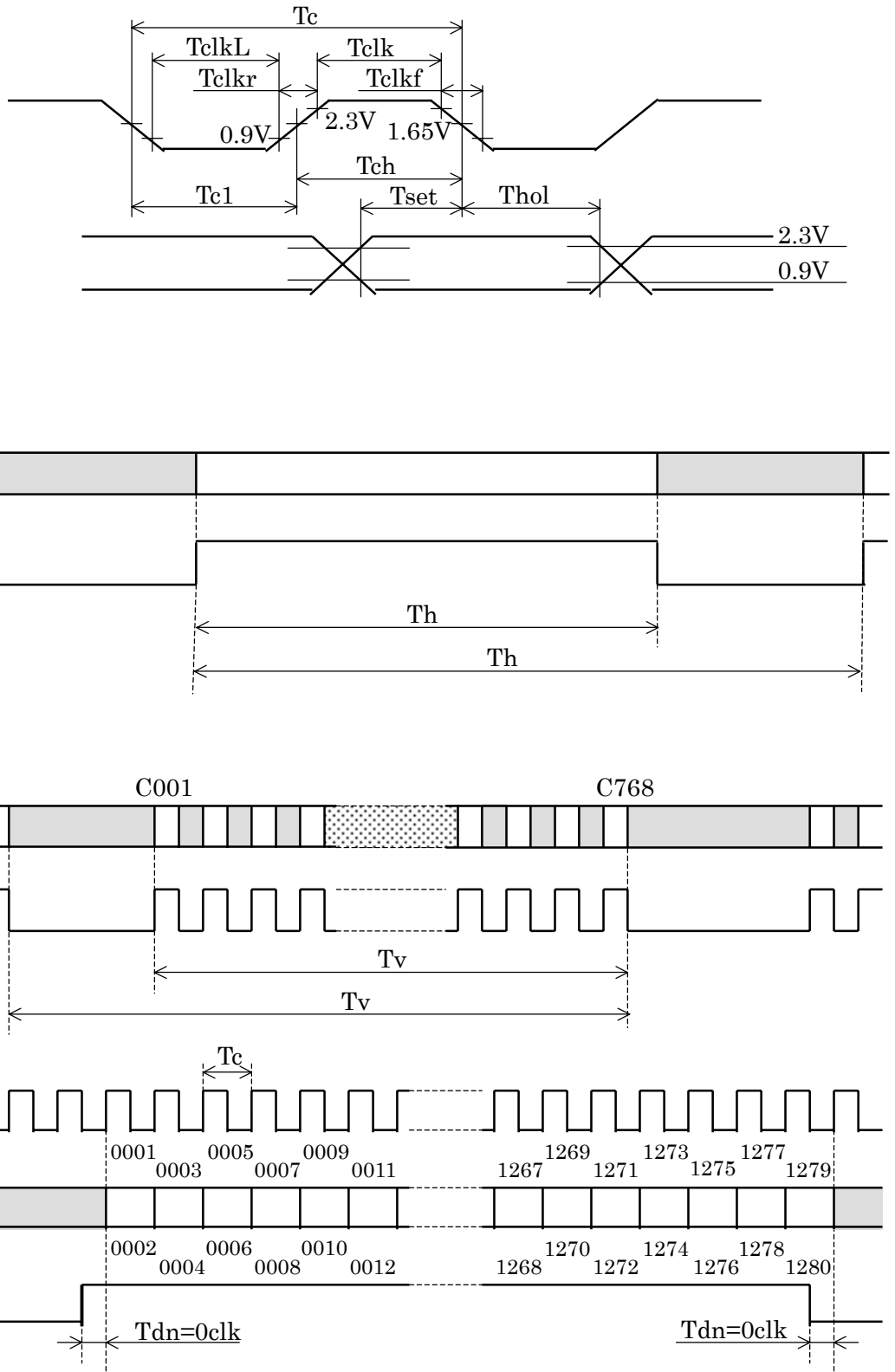

Fig.10-3.Input Signal Timing Chart

DOCUMENT CONTROL SECTION

DATE

						FLC43XWC6V-02	
						Tech Bes LCD-00087	
						CUST.	
EDIT	DATE	DESIG.	CHECK	APPR.	DESCRIPTION	FUJITSU LIMITED	
DESIG.			CHECK	APPR.		15/	

A

B

C

D

E

F

10-4. Correspondence between Data and Display Position

Fig.10-3 shows the Correspondence between Data and Display Position.

	S0001	S0002	S0003	S0004	S0005	S0006	S0007	S0008	S3071	S3072
C001	RO 0001	GO 0001	BO 0001	RE 0002	GE 0002	BE 0002	RO 0003	GO 0003		GE 1280	BE 1280
C768	RO 0001	GO 0001	BO 0001	RE 0002	GE 0002	BE 0002	RO 0003	GO 0003		GE 1280	BE 1280

Fig.10-4. Correspondence Data and Display Position

10-5. Power Supply Sequence

The sequence of input signals and On/Off of the power supply of this LCD module should be in the specification shown in Fig.10-4 to prevent latch-up of the driver ICs and DC driving of the LCD panel.

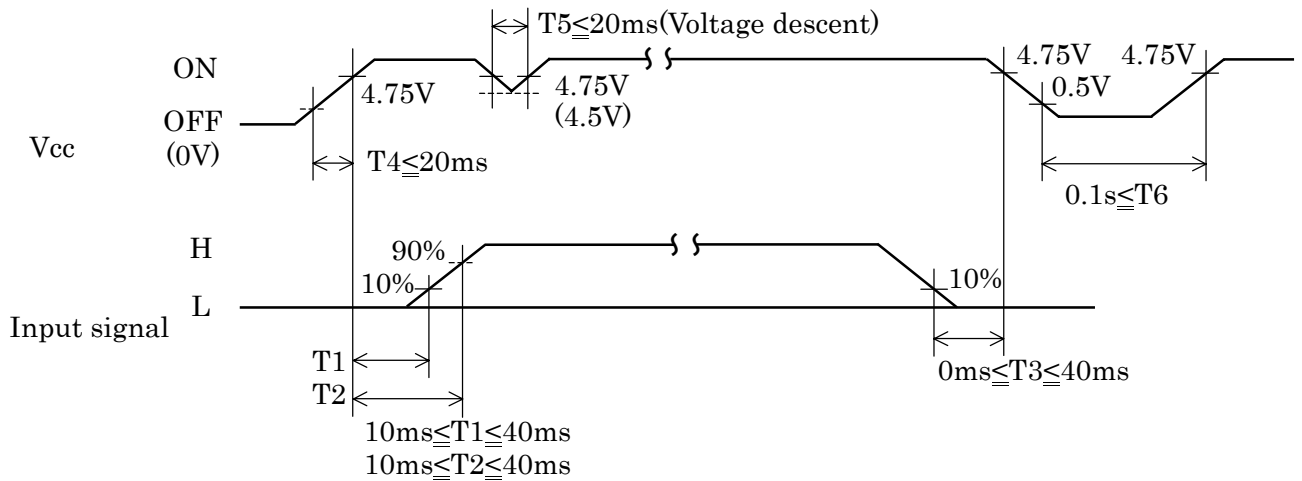

Fig.10-5. Power Supply Sequence

DOCUMENT CONTROL SECTION

DATE

						FLC43XWC6V-02					
						Tech Bes LCD-00087					
						CUST.					
EDIT	DATE	DESIG.	CHECK	APPR.	DESCRIPTION	FUJITSU LIMITED					
DESIG.			CHECK	APPR.							

11. BACKLIGHT SPECIFICATIONS

11-1. Pin Configuration for Backlight

Table 11-1(a) and 11-1(b) shows the description and pin assignment of the connectors (CN-A and B) for the Backlight of this LCD module.

Table 11-1(a) Pin Assignment of CN-A

Pin	Signal	Function
1	V _{L1}	Power supply for CCFL 1
2	V _{L2}	Power supply for CCFL 2
3	NC	
4	GND	Ground (for V _{L1} , 2)

Table 11-1(b) Pin Assignment of CN-B

Pin	Signal	Function
1	V _{L3}	Power supply for CCFL 3
2	V _{L4}	Power supply for CCFL 4
3	NC	
4	GND	Ground (for V _{L3} , 4)

Cable color (CN-A and B) : White at GND, Pink at V_{L1},2,3 and 4

Connector : Housing : BHR-04VS-1
 : Contact : SBH-001T-P0.5
 User's Connector : Post with base : SM04(4.0)B-BHS-1-TB
 Supplier : Japan Solderless Terminal Trading Company LTD. (J.S.T.)

11-2. CCFL

Supplier : SANKEN ELECTRIC CO., LTD Part No. _____

11-3. Life

The life of the backlight is a minimum of 25,000 hours at the following conditions.

(1) Working conditions

Ambient temperature : 25 ± 5°C
 Tube current(I_L) : (10.5mA or less)

(2) Definition of life

Brightness becomes 50% or below 50% of the minimum brightness value shown in Table 9-1.
 The lamp cannot be lit by the breakdown voltage of 1600Vrms.
 Lamp is flashing.

11-4. Lamp Assembly set (for replacement)

Lamp Assembly set (with charge) is prepared for maintenance.
 This set consists of an upper lamp assembly and a lower lamp assembly.

Type number : _____

DATE DOCUMENT CONTROL SECTION

						FLC43XWC6V-02	
						Tech Bes LCD-00087	
						CUST.	
EDIT	DATE	DESIG.	CHECK	APPR.	DESCRIPTION	FUJITSU LIMITED	
DESIG.			CHECK		APPR.	17/	

12. APPEARANCE SPECIFICATIONS

12-1. Zone

- Inside display dot area (369.6× 221.8mm)
- Display dot area means active area.
- One pixel consists of 3 dots (red, green and blue).
- Foreign particle and scratch unarmful to display image, such as the foreign particle under polarizer film but outside of the display area and scratch on metal bezel, backlight module or polarizer film out of the display area, etc., are not counted.

12-2. Bright spots

(1) Bright spots by the defect of TFT.

- Visible under bias of 2% ND filter High bright spot R・G
- Visible under 5% but invisible under 2% ND filter Low bright spot R・G・B
- Invisible under bias of 5% ND filter Not counted

(2) Bright spots by the light passing through tears, breaks, etc in color filter.

- Exceed size of a half dot High bright spot
- A half dot or less Not counted

(3) Bright spots by the light passing through tears, breaks, etc in chromium mask.

- Exceed 50μm High bright spot
- 50μm or less Not counted

12-3. Test condition

- Inspector must observe the LCD screen from the normal direction under the illumination by a single 20W fluorescent lamp. The distance between the LCD screen and the inspector should be a height of 50cm above the worktable.
The vertical illuminance is 300 to 600lux (reference value).
- Bright spot should be counted under entire black screen.
- Dark spot should be counted under entire white screen.
- Frame frequency should be 60Hz.

12-4. Specifications

Table 12-4 shows the appearance standard.

(Note1) Please do not mistake a single bright spot for a bright spot connection due to Cs(supplemental capacitance) line at the center of each dot.

(Note2) If a pixel is dark partially, it connects into the number of dark spots in accordance with following rule.

(a) $S < 1/3$: Not count. Only one of 4 dark connection is allowed.

(b) $1/3 \leq S < 2/3$: Considered as 0.5 dot.

(c) $2/3 \leq S$: Considered as 1 dot.

(S=Dark spot size/dot size)

DOCUMENT CONTROL SECTION

DATE

						FLC43XWC6V-02	
						Tech Bes LCD-00087	
						CUST.	
EDIT	DATE	DESIG.	CHECK	APPR.	DESCRIPTION		
DESIG.			CHECK		FUJITSU LIMITED		
						18/	

Table 12-4. Appearance specifications

No.	Item	Judgment method and standard	
1	Bright spot (high and Low)	≤ 10 dots (Note 1)	
2	Bright spot connection (high and low)	≤ 2 pair (2 dot connection in horizontal) (Note 1)	
3	Total of bright spot	≤ 7 dots	
4	Dark spot	≤ 12 dots (Note 2)	
5	Dark spot connection	≤ 5 pairs (2 dot connection in horizontal) (Note 2)	
6	Total of dark spot	≤ 12 dots (Note 2)	
7	Total of dot defect (bright and dark)	≤ 12 dots	
8	Distance of bright spot	high-hgh	≥ 10 mm
		others	≥ 3 mm
9	Distance of dark spot	≥ 3 mm	
10	Scratch on polarizer, line shape	$0.3 < W \leq 0.5, L \leq 0.5$	≤ 5
		$0.5 < W$	0
		$W < 0.3$	Ignore
11	Dent on polarizer, dot shape	$D < 0.5$	≤ 6
12	Nick on polarizer, line shape	$L < 10.0$	≤ 6
13	Black spot (Foreign circular matter)	$D < 0.5$	≤ 5
		$0.5 < D \leq 0.6$	≤ 1
		$0.6 < D \leq 1.0$	≤ 1
	White spot (Foreign circular matter)	$D < 0.5$	≤ 5
		$0.5 < D \leq 0.8$	≤ 1
		$0.8 < D \leq 1.0$	≤ 1
14	Lints, black line	$W \leq 0.1, L < 3.0$ ≤ 5	
	Lints, white spot	$W < 0.05, 0.1 < L \leq 0.5$ $W \leq 0.05, 0.5 < L \leq 1.0$ ≤ 6 ≤ 2	

D:Average diameter [mm], W:Width [mm], L:Length [mm], S=(bright spot size)/(dot size)

DOCUMENT CONTROL SECTION

DATE

						FLC43XWC6V-02	
						Tech Bes LCD-00087	
						CUST.	
EDIT	DATE	DESIG.	CHECK	APPR.	DESCRIPTION	FUJITSU LIMITED	
DESIG.			CHECK		APPR.	19/	

13. ENVIRONMENTAL SPECIFICATIONS

Table 13-1 shows the environmental specifications.

Table 13-1. Environmental Specifications

Item	Condition		Remark
Temperature	Operation	0~50°C	Temperature on surface of LCD panel (display area.)
	Storage	-20~60°C	
Humidity	Operation	20~85%RH	Maximum wet-bulb temperature should not exceed 29°C. No condensation.
	Storage	5~85%RH	
Vibration	Non-operation	10~500Hz, 1 cycle/20minute, 2G, 1.5mm max, 2hour each X, Y and Z directions	For single module without package.
Shock	Non-operation	30G, 6ms, 1time each ±X, ±Y and ±Z directions.	

NOTE: Table 13-2 and Fig. 13-1 show the shock resistance standard when module is packaged.

Table 13-2. Shock Resistance Standard when Module is Packaged

Dropping location	Dropping height	Count
A ~ J	60cm	1 time

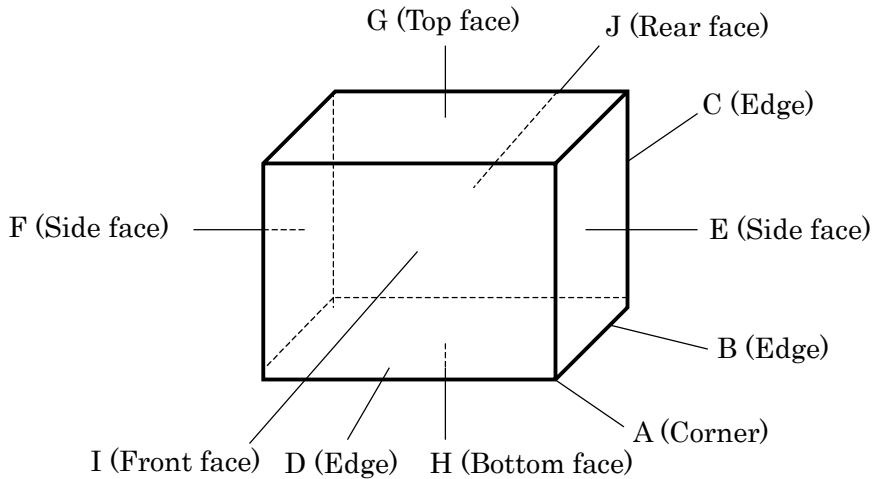

Fig.13-1. Direction to apply shock to package

DOCUMENT CONTROL SECTION

						FLC43XWC6V-02	
						Tech Bes LCD-00087	
						CUST.	
EDIT	DATE	DESIG.	CHECK	APPR.	DESCRIPTION		
DESIG.			CHECK		APPR.		
						FUJITSU LIMITED	
						20/	

14. INDICATIONS

This module has the following indications.

- (1) Product name : LCD unit
- (2) Model number : FLC43XWC6V-02
- (3) Product drawing number: NA19020-C553

(4) Manufacturing number : 0 Y 0 0 0 0 1

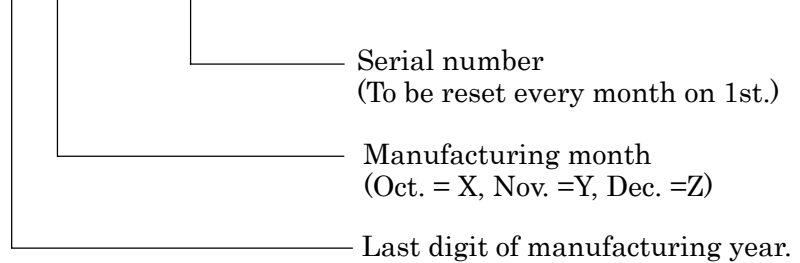

- (5) Version number : 01A (Example)
 -1st 2 digits "01" means operational version.
 -3rd alphabet means functional version.

(6) Country of origin : MADE IN JAPAN

(7) Company name : FUJITSU LIMITED

(8) Disposal method of cold-cathode tubes. (See Fig.14-1)

(9) Caution when changing cold-cathode tubes. (See Fig. 14-2)

• THIS TFT COLOR LCD CONTAINS GOLD CATHODE FLUORESCENT LAMPS. PLEASE FOLLOW LOCAL ORDINANCES OR REGULATIONS FOR ITS DISPOSAL.

• 当該液晶ディスプレイユニットには蛍光管が組み込まれていますので、地方自治体の条例または規則に従って廃棄して下さい。

Fig.14-1

• WHEN CHANGING COLD CATHODE FLUORESCENT LAMPS, FOLLOW OPERATING SPECIFICATIONS, ESPECIALLY BE CAREFUL ABOUT THE LAMPS SIDE-EDGE.

• 蛍光管の交換は作業仕様書に従って行って下さい。特に蛍光管ホルダ側面のエッジに気をつけて下さい。

Fig.14-2

LCD unit

FLC43XWC6V-02 0X50015
 NA19020-C553 01A
 MADE IN JAPAN/FUJITSU LIMITED

Fig.14-3 Product label (example)

15. PACKAGING

Separately specified in packaging specifications.

15-1. Packaging specifications

- (1) 5 LCD modules / 1 package.
- (2) Weight: approximately 13kg / 1 package.
- (3) Outline dimensions : T.B.D.

15-2. Packaging method

Fig.15-2 (a),(b),(c),(d) show the packing method.

DOCUMENT CONTROL SECTION

						FLC43XWC6V-02	
						Tech Bes LCD-00087	
						CUST.	
EDIT	DATE	DESIG.	CHECK	APPR.	DESCRIPTION		
DESIG.			CHECK		FUJITSU LIMITED		
						21/	

A

A

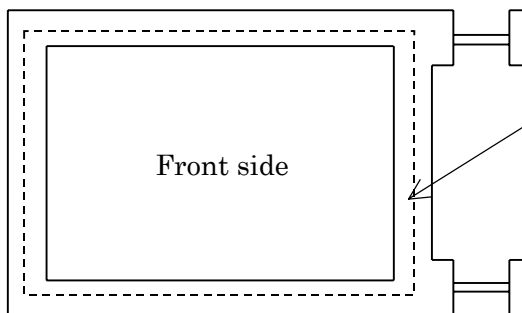

B

B

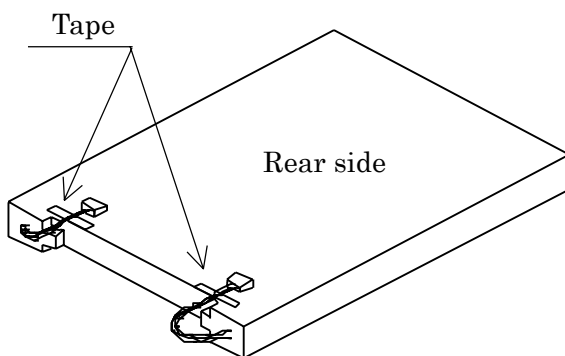

C

C

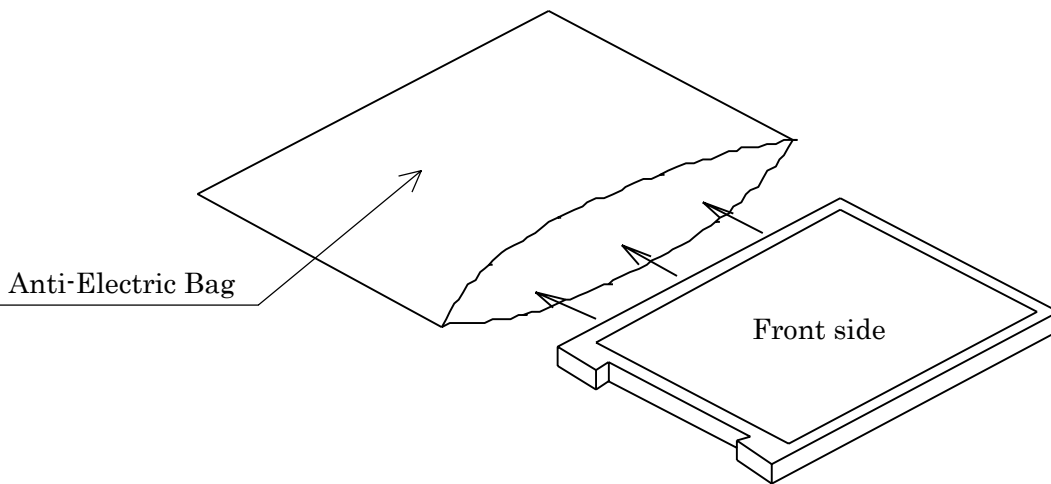

D

D

Fig.15-2(a) Packaging Method

DOCUMENT CONTROL SECTION

DATE

E

F

FLC43XWC6V-02

Tech Bes LCD-00087

CUST.

EDIT	DATE	DESIG.	CHECK	APPR.	DESCRIPTION
DESIG.			CHECK		APPR.

FUJITSU LIMITED

CONTAINER

22/

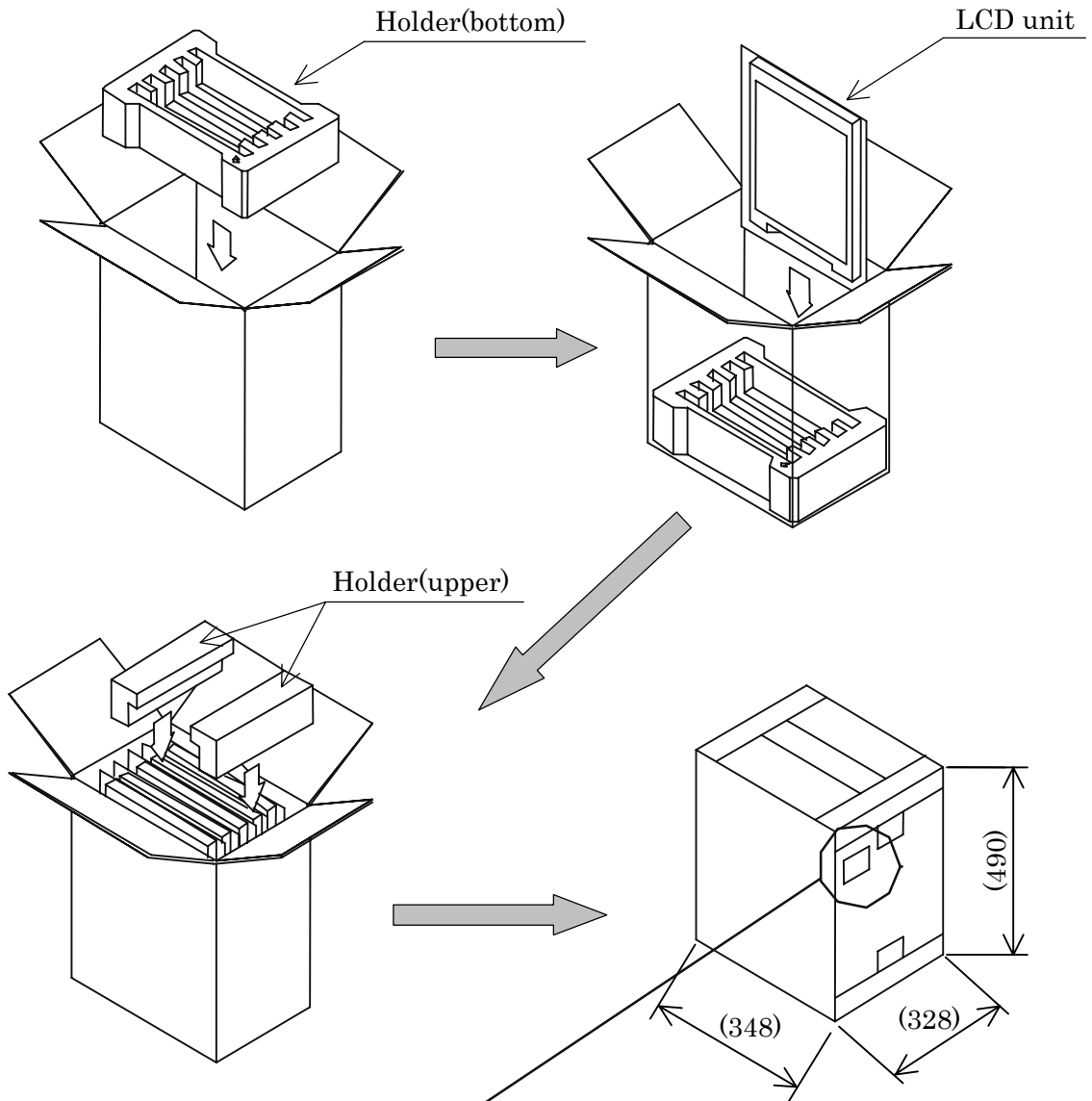

Label(example)

型 格 (TYPE)	FLC43XWC6V-02	数 量 (QTY.)	5
図 番 (DRWG. NO.)	NA19020-C553	版 数 (REV. NO.)	01A
	9X00001		
	9X00002		
	9X00003		
	9X00004		
	9X00005		
<div style="border: 1px solid black; display: inline-block; padding: 2px;"> バーコード </div>		MADE IN JAPAN	

- Taping
 Upper : H or I method
 Bottom : H method
- Upper and bottom holders should be anti-electrostatic type.

Fig.15-2(b) Packaging Method

DOCUMENT CONTROL SECTION

						FLC43XWC6V-02	
						Tech Bes LCD-00087	
						CUST.	
EDIT	DATE	DESIG.	CHECK	APPR.	DESCRIPTION		
DESIG.			CHECK		APPR.		
FUJITSU LIMITED						23/	

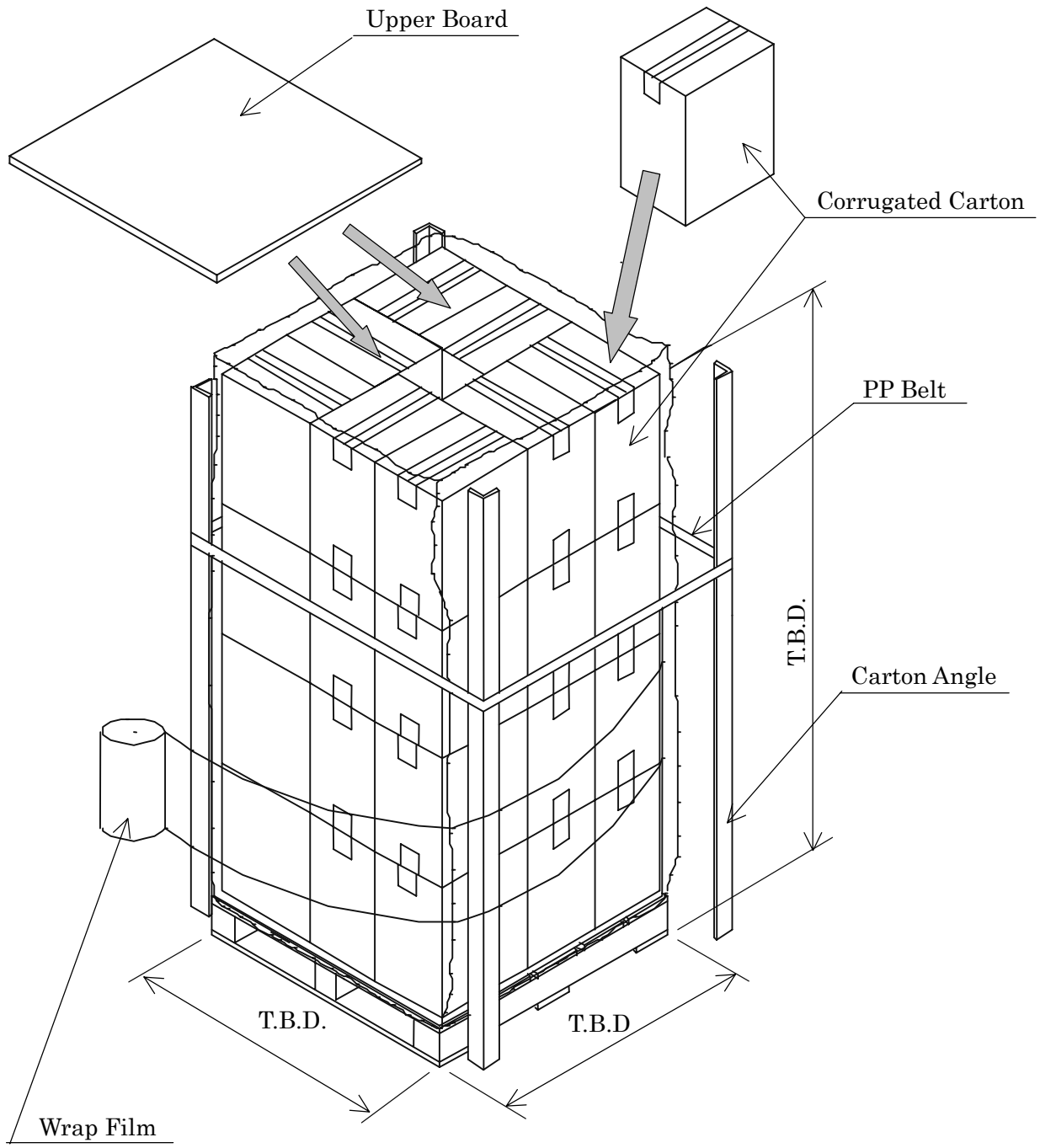

Fig.15-2(c) Packaging Method

DOCUMENT CONTROL SECTION
DATE

						FLC43XWC6V-02	
						Tech Bes LCD-00087	
						CUST.	
EDIT	DATE	DESIG.	CHECK	APPR.	DESCRIPTION		
DESIG.			CHECK		APPR.	FUJITSU LIMITED	
						24/	

A

A

Cushioning material

Corrugated carton(A)
With LCD modules

B

B

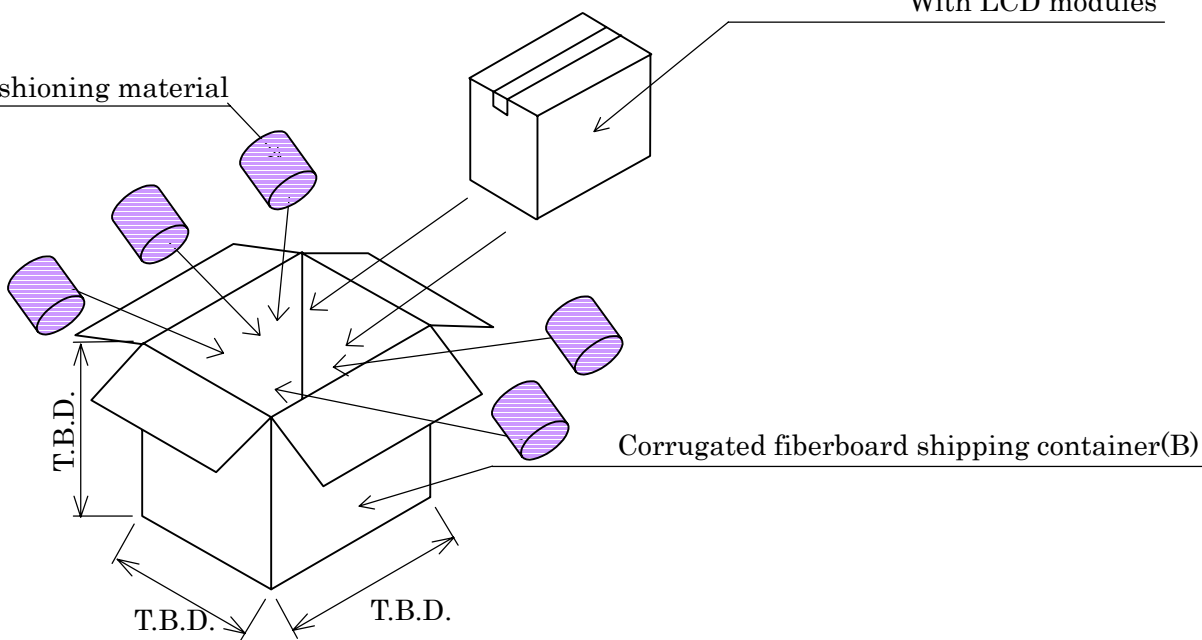

Corrugated fiberboard shipping container(B)

C

C

Note 1) The carton (A) should be placed in the middle of the container(B) with enough cushioning materials.

D

D

Figure.15-2(d) Packaging Method

DOCUMENT CONTROL SECTION

DATE

E

F

FLC43XWC6V-02

Tech Bes LCD-00087

CUST.

EDIT	DATE	DESIG.	CHECK	APPR.	DESCRIPTION
DESIG.			CHECK		APPR.

FUJITSU LIMITED

DATE

25/

16.WARRANTY

The warranty period is one year after manufacturing. Products which fail during this period are repaired or replaced without charge, unless the failure is caused by user.

17.PRECAUTIONS

Adhere to the following precautions to properly use this LCD module.

(1) Fail safe design

LCD module has an inherent chance of failure. Customers must protect against injury, damage or loss from such failures by incorporating safety design measures into your facility and equipment such as redundancy, fire protection, and prevention of over-current levels and other abnormal operating conditions.

(2) Handling of LCD panel

Do not apply any strong mechanical shock to the LCD panel.

Since the LCD panel is made of glass, excessive shock may damage the panel or cause a malfunction.

Do not press hard on the LCD panel surface.

In the LCD panel, the gap between two glass plates is kept precisely and uniformly to maintain display's characteristics and reliability. If this panel is pressed hard, the following troubles occurs.

- (a) Ununiformity of color
- (b) Orientation of liquid crystal becomes disordered

Problem (a) returns to normal after a while. Problem (b) returns to normal if power is shut off once then turned on again.

However these operations should be avoided to insure reliability.

Do not scratch the polarizer film on the LCD panel surface.

- Do not press or rub the display surface with a hard tool, pincet, etc.
- For handling, use cotton or conductive gloves so that the display surface is not stained.
- For If the display surface is stained by dust or dirt, clean it as follows with a soft cloth (deer skin, etc.)

[Dust] Wipe off with a soft cloth. (do not rub.)

[Dirt] Wipe off lightly with a soft cloth after soaking in the clear water and squeezing hard out of water drops. Only if the dirt is hardly wiped off, use isopropyl alcohol or ethanol.

Be careful not to splash the water or the solvent and water penetrated between the polarizer and the LCD panel.

Do not use solvents such as ketone (acetone, etc.) and aromatics (xylene, toluene, etc.)

- If saliva or water drops are left for long time, it may deform partial deformation or discolored. Wipe off immediately in the same way as for dirt.
- Do not allow oil to adhere to the module, since the cleaning of oil is difficult.

Do not place or contact objects on the display surface for a long period of time.

That's because this may make some parts of the LCD module distorted and the display quality may decline.

DOCUMENT CONTROL SECTION

DATE

						FLC43XWC6V-02	
						Tech Bes LCD-00087	
						CUST.	
EDIT	DATE	DESIG.	CHECK	APPR.	DESCRIPTION		
DESIG.			CHECK		FUJITSU LIMITED		
						26/	

(3) Handling of LCD module

Do not pull the cold-cathode tube cable strongly.

If the cable is pulled with the load of 2kg or more, the cable may be damaged or reliability may decrease.

Assemble the module into user's system in a dust free environment.

If conductive foreign matter adheres to the module, failures may occur.

Take anti-static measures for assembling the module.

Since the LCD module contains CMOS-ICs, the following considerations are necessary.

- For assembling the module, operator should be grounded and wear cotton or conductive gloves.
- Floor of work area and work table to assemble the LCD module should be covered with electrostatic shielding in order to discharge static electricity via an earth wire.
- If necessary, ground operation tools (soldering iron, radio pliers, pincet, etc.).
- Do not take the module out of the conductive bag until the time when the module is assembled.
- Assemble the module under low humidity (50%RH or less).

Do not pull the connecting cable on the rear face of the LCD module strongly.

Do not disassemble or remodel the LCD module.

If this LCD module is disassembled or remodeled, it may have some trouble, or the display quality and reliability may not be assured.

(4) Precautions for operating the LCD module

Adhere to the specified power supply sequence.

If not followed, the CMOS-IC may cause a latch-up, or the DC voltage may be applied the liquid crystal, and a failure or serious deterioration in display quality may occur.

Do not operate the LCD module when condensation is present.

If the LCD module is operated when condensation is on the terminals of the LCD panel, the terminals cause electrochemical reaction, and may reach disconnection. Condensation easily occurs especially when the module is moved from a cold environment to a warm environment.

Trouble that occurs when the LCD module is used at not recommended temperature.

- Operation at high temperature(>50°C) :Display colors shift to blue.
- Storage at high temperature(>60°C) :The polarizer film deteriorates and contrast decreases.
- Operation at low temperature(<0°C) :The response speed decreases considerably.
- Storage at low temperature (<-20°C) :The liquid crystal may solidify and become damaged.

Always input the control signals at the correct timing.

If control signals (DCLK, or ENAB) are not input, or if the timing is out of the specified timing, DC voltage may be applied to the liquid crystal and, as a result, cause image sticking or deterioration of contrast.

DOCUMENT CONTROL SECTION
DATE

						FLC43XWC6V-02	
						Tech Bes LCD-00087	
						CUST.	
EDIT	DATE	DESIG.	CHECK	APPR.	DESCRIPTION		
DESIG.			CHECK		FUJITSU LIMITED		
						27/	

(5) Precautions on designing module mounting

Do not press the display surface and bottom face of the LCD module.

Display quality or reliability may be deteriorated if the installation of the LCD module is inappropriate and, as a result, excessive pressure is applied to the surface of LCD screen. Brightness uniformity or the reliability of CCFL may decrease if the pressure is applied to the backlight module.

Consider the module mounting design, so that twisting and bending do not occur to the LCD module.

Excessive twisting and bending may damage display quality and reliability.

The power cable length between the LCD module and inverter should not be extended.

Otherwise the backlight may not light or flickering may occur.

Do not make the power cable of the backlight clung to a metal plate, etc.

Backlight frequency current for backlight driving may leak to the metal and desired brightness may not be assured.

When Mounting LCD module with M4 screw (x4) should be screw up under 5.75kgf torque.

(6) Storage method

Do not store the LCD module in an atmosphere of organic solvent or corrosive gas.

In an organic solvent atmosphere, the polarizer film discolors and display quality deteriorates.

In a corrosive gas environment, various problems may occur.

Store the LCD module in a Fujitsu package.

At storing, Fujitsu packages can be stacked up to 4 boxes.

The LCD module is in an anti-static bag. Keep the module in that status.

It is recommended that the storage environment should be humidity controlled, cool and dark.

Recommended storage environment

- Place :Dark (avoid direct sunlight)
- Temperature : 10~35°C
- Humidity : 50~60%RH

Note) If the module is left in an environment of 60 or more for a long period of time, optical characteristics may deteriorate.

(7) Storage method

! If the LCD panel is damaged, do not inhale or allow the liquid crystal to enter the mouth

If the liquid crystal contacts the body or cloths, wash it off with soap immediately. Follow precautions for regular electronic components.

Solder flux on the printed circuit board is harmless to the quality and reliability of LCD module.

Fujitsu is practicing non-wash technology on module assembly process.

DOCUMENT CONTROL SECTION

DATE

						FLC43XWC6V-02	
						Tech Bes LCD-00087	
						CUST.	
EDIT	DATE	DESIG.	CHECK	APPR.	DESCRIPTION		
DESIG.			CHECK		FUJITSU LIMITED		
						28/	

18. PRECAUTIONS FOR USE

A

This Product is designed, developed and manufactured as contemplated for general use, including without limitation, general office use, personal use, household use, and ordinary industrial use, but is not designed, developed and manufactured as contemplated for use accompanying fatal risks or dangers that, unless extremely high safety is secured, could lead directly to death, personal injury, severe physical damage or other loss (hereinafter “High Safety Required Use”), including without limitation, nuclear reaction control in nuclear facility, aircraft flight control, air traffic control, mass transport control, medical life support system, missile launch control in weapon system. If customer’s product possibly falls under the category of High Safety Required Use, please consult with our sales representatives in charge before such use. In addition, Fujitsu shall not be liable against the Customer and/or any third party for any claims or damages arising in connection with the High Safety Required Use of the Product without permission.

A

B

B

19. MISCELLANEOUS

Specifications of the TFT-LCD panel and other components used in the LCD module are subject to change. Both parties shall discuss together before change.

C

If any doubt is raised in the content of the specifications, both parties shall discuss and make best effort for the agreement.

C

D

D

DOCUMENT CONTROL SECTION

DATE

E

						FLC43XWC6V-02	
						Tech Bes LCD-00087	
						CUST.	
EDIT	DATE	DESIG.	CHECK	APPR.	DESCRIPTION		
DESIG.			CHECK		FUJITSU LIMITED		
						29/	

F

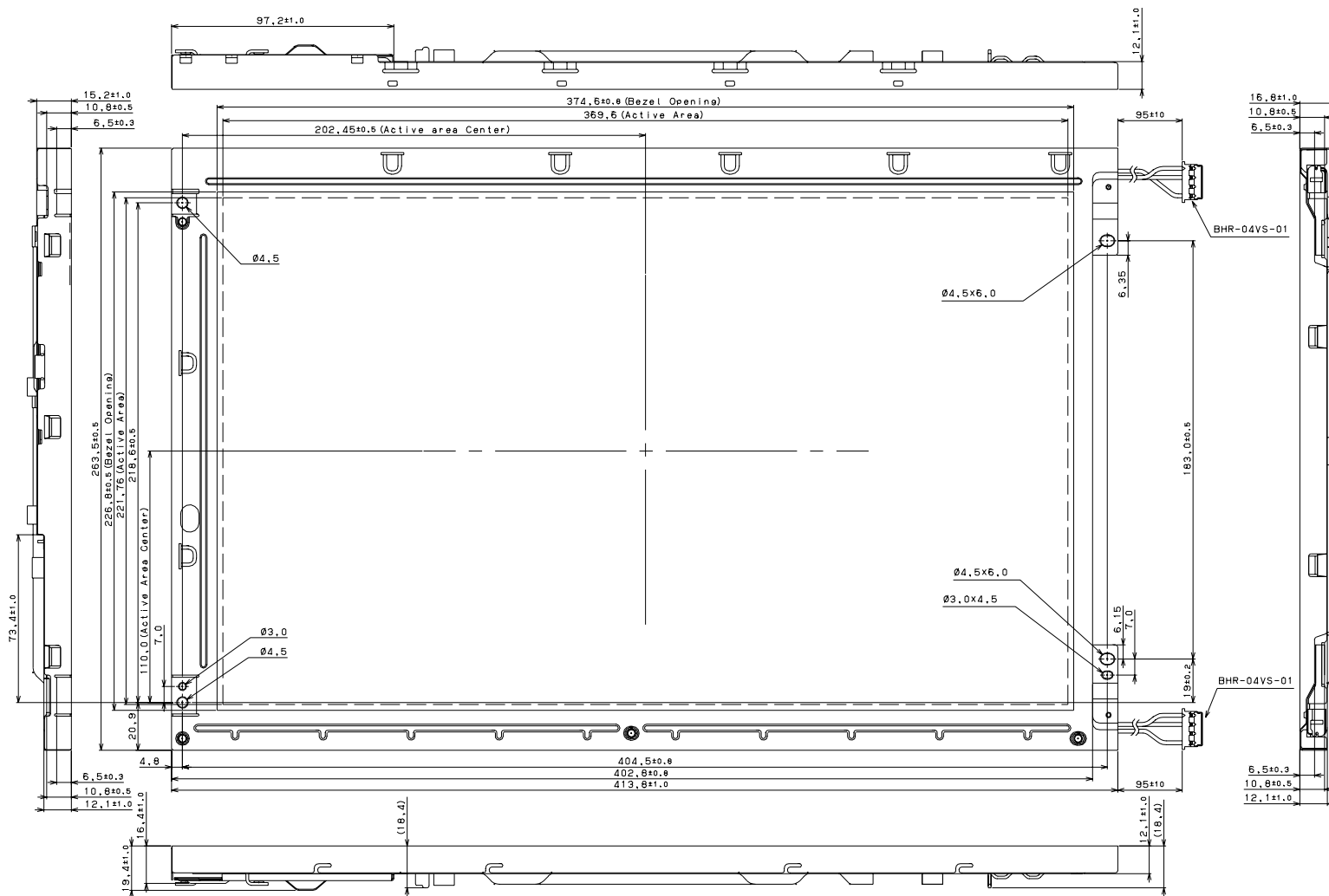

Front View

FLC43XWC6V-02		
Tech Bes LCD-00087		
30/		

