



# DATA IMAGE CORPORATION

## TFT Module Specification

ITEM NO.: FG050605DNCWBGL4

### Table of Contents

- 1. COVER & CONTENTS ..... 1
- 2. RECORD OF REVISION ..... 2
- 3. APPLICATION..... 3
- 4. GENERAL SPECIFICATIONS ..... 3
- 5. ELECTRICAL CHARACTERISTICS ..... 3
- 6. BLOCK DIAGRAM ..... 4
- 7. PIN CONNECTIONS ..... 5
- 8. INTERFACE SPECIFICATIONS ..... 6
- 9. OPTICAL CHARACTERISTIC ..... 9
- 10. QUALITY ASSURANCE ..... 11
- 11. LOT NUMBERING SYSTEM ..... 12
- 12. LCM NUMBERING SYSTEM ..... 12
- 13. PRECAUTIONS IN USE LCM ..... 13
- 14. OUTLINE DRAWING ..... 14
- 15. PACKAGE INFORMATION ..... 15

Customer Companies	R&D Dept.	Q.C. Dept.	Eng. Dept.	Prod. Dept.
	<i>Alex</i>	<i>Eric</i>	<i>Gary</i>	<i>Huang</i>
Approved by	Version:	Issued Date:	Sheet Code:	Total Pages:
	D	2007/3/13		15

**2. RECORD OF REVISION**

Rev	Date	Item	Page	Comment
A	26/MAY/06			New Release
B	6/JUL/06	8.1	6	Modify input timing.
C	24/JUL/06	5,10	3,11	Modify Storage temperature from -30~80°C to -40~80°C.
D	13/MAR/07	8.3	8	1. Update COLOR DATA INPUT ASSIGNMENT DATA.

### 3. APPLICATION

Digital equipments which need color display, such as P.O.S, medical equipments and industrial equipments.

### 4. GENERAL SPECIFICATIONS

Parameter	Specifications	Unit
Display resolution	960(W) x 234(H)	dot
Active area	113.28(W) x 84.708(H)	mm
Screen size	5.6(Diagonal)	inch
Dot pitch	0.118(W) x 0.362(H)	mm
Color configuration	R.G.B. Stripe	
Overall dimension	126.5(W) x 100(H) x 11.1(D)	mm
Weight	160	g
Surface treatment	Anti-glare(Haze=6% typical)	
View Angle direction	6 o'clock	
Our components and processes are compliant to RoHS standard		

### 5. ELECTRICAL CHARACTERISTICS

T<sub>a</sub>=25°C

Parameter	Symbol	MIN.	Typ.	MAX.	Unit	Remark
Power Supply voltage	V <sub>CC</sub>	+3.0	+3.3	+3.6	V	
Power Supply Current	I <sub>CC</sub>		150	200	mA	V <sub>CC</sub> =3.3V
"H" level logical input voltage	V <sub>IH</sub>	0.7V <sub>CC</sub>	--	--	V	
"L" level logical input voltage	V <sub>IL</sub>	--	--	0.3V <sub>CC</sub>	V	
Operating temperature	Topa	-20	--	70	°C	Ambient temperature
Storage temperature	Tstg	-40	--	80	°C	Ambient temperature

#### 5.1 Backlight driving conditions

Parameter	Symbol	Condition	Min.	Typ.	Max.	Unit	Remark
Lamp voltage	V <sub>L</sub>		-	470	528	Vrms	Note 1
Lamp current	I <sub>L</sub>		5.9	6	6.1	mArms	
Frequency	F <sub>L</sub>	-	-	60	80	kHz	Note 1,2
Lamp starting voltage	V <sub>S</sub>	T <sub>a</sub> = 25°C	-	-	650	Vrms	Note1,3
		T <sub>a</sub> = 0°C	-	-	910	Vrms	Note 1,3
Lamp life time		T <sub>a</sub> = 25°C	20000	30000	--	hrs	

Note 1: Reference value, correct value is subject to final backlight specification which will be decided in the future.

Note 2: The lamp frequency should be selected as different as possible from display horizontal synchronous signal to avoid interference.

Note 3: For starting the backlight unit, the output voltage of DC/AC's transformer should be larger than the maximum lamp starting voltage.

**6. BLOCK DIAGRAM**

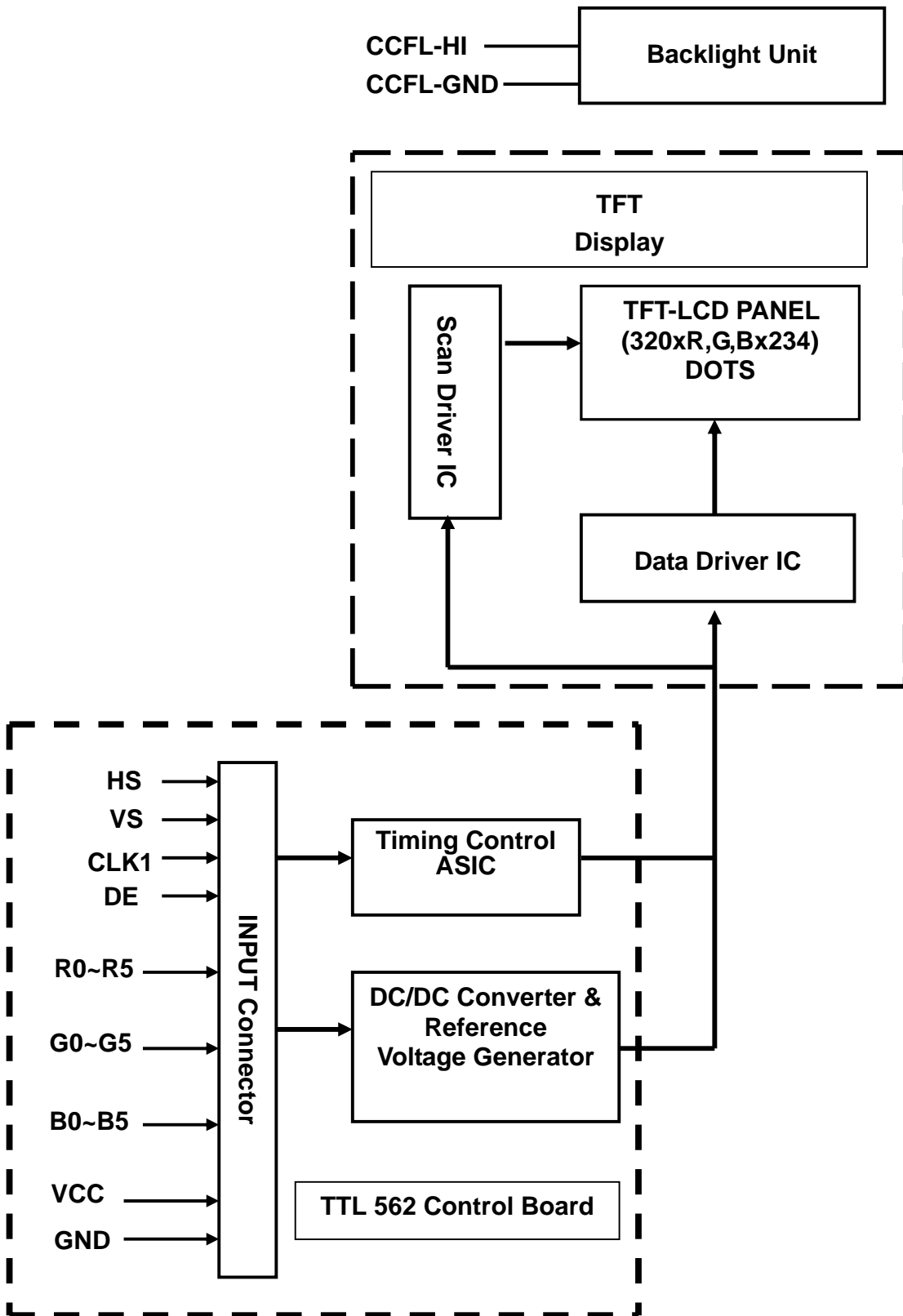

## 7. PIN CONNECTIONS

### 7.1 P1 Input Pins Connection ( To TTL562 control board )

Pin No	Symbol	Function	Remark
1	GND	Ground for logic circuit	
2	CLK1	Data sampling clock	
3	HS (HSYNC)	Horizontal synchronous signal	
4	VS (VSYNC)	Vertical synchronous signal	
5	GND	Ground for logic circuit	
6	R0	Red pixel data(LSB)	
7	R1	Red pixel data	
8	R2	Red pixel data	
9	R3	Red pixel data	
10	R4	Red pixel data	
11	R5	Red pixel data(MSB)	
12	GND	Ground for logic circuit	
13	G0	Green pixel data(LSB)	
14	G1	Green pixel data	
15	G2	Green pixel data	
16	G3	Green pixel data	
17	G4	Green pixel data	
18	G5	Green pixel data(MSB)	
19	GND	Ground for logic circuit	
20	B0	Blue pixel data(LSB)	
21	B1	Blue pixel data	
22	B2	Blue pixel data	
23	B3	Blue pixel data	
24	B4	Blue pixel data	
25	B5	Blue pixel data(MSB)	
26	GND	Ground for logic circuit	
27	DE	Data Enable (connected to GND, if sync mode)	
28	Vcc	Power Supply : +3.3V	
29	Vcc	Power Supply : +3.3V	
30	NC	No Connection	
31	NC	No Connection	
32	GND	Ground for logic circuit	

## 8. INTERFACE SPECIFICATIONS

### 8.1 Input Signal Timing Specification

The specification of input signals timing is as the following table and timing diagram.

Signal	Parameter	Symbol	MIN.	TYP.	MAX.	Unit	Remarks
CLK1	Pixel clock Frequency	fclk1		6.25		MHz	
	Pixel clock period	Tck		160		ns	
	Rise time	Trck		6		ns	
	Fall time	Tfck		6		ns	
VS	Vertical Frequency	fv		59		Hz	
	Vertical period	Tvp		259		Thp	
	Vertical display blank period	Tvdb		25		Thp	
	Vertical display active period	Tvda		234		Thp	
	Vertical sync. front porch	Vfp		16		Thp	
	Vertical sync. back porch	Vbp		6		Thp	
	Vertical sync. pulse width	Vpw		3		Thp	
HS	Horizontal period	Thp		408		Tclk1	
	Horizontal display blank period	Thdb		88		Tclk1	
	Horizontal display active period	Thda		320		Tclk1	
	Horizontal sync. front porch	Hfp		47		Tclk1	
	Horizontal sync. back porch	Hbp		36		Tclk1	
	Horizontal sync. pulse width	Hpw		5		Tclk1	
DATA R,G,B	Setup time	Tsd	10			ns	
	Hold time	Thd	10			ns	

Note: 1.Data is latched at falling edge of CLK1 in the spec. CLK1 should appear during all blanking period.

2.VS and HS are negative polarity in the spec.

3.HS should appear during blanking period of frame cycle.

4. $Tvp = Tvdb + Tvda$ ,  $Tvdb = Vbp + Vfp + Vpw$

5. $Thp = Thdb + Thda$ ,  $Thdb = Hbp + Hfp + Hpw$

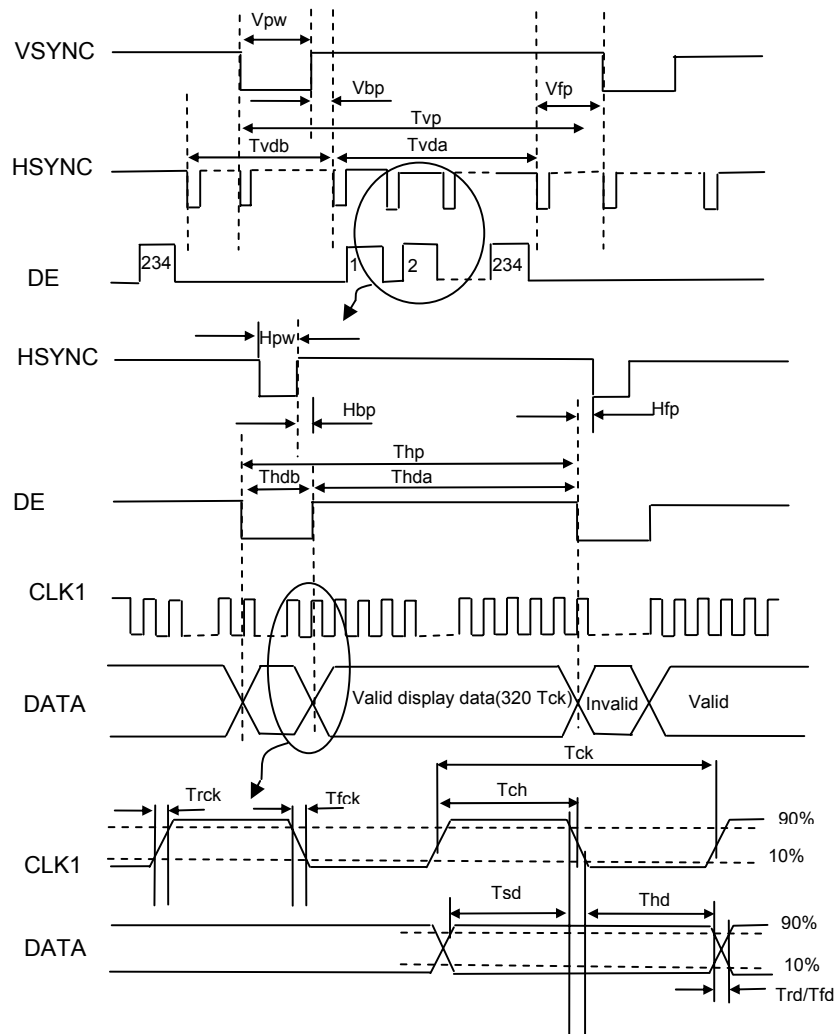

## 8.2 Power Off/On Sequence Timing

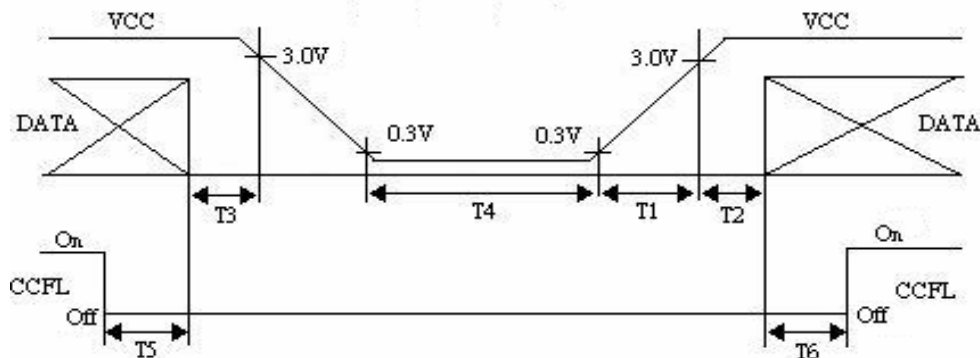

### Timing Specifications:

$$0 < T1 \leq 15\text{mS}$$

$$T2 > 0.5\text{S}$$

$$0 < T3 \leq 0.1\text{S}$$

$$T4 > 1\text{S}$$

$$T5 > 0.1\text{S}$$

$$T6 > 0.1\text{S}$$

### 8.3 Color Data Input Assignment

		Data Signal																	
		Red						Green						Blue					
Color		R5	R4	R3	R2	R1	R0	G5	G4	G3	G2	G1	G0	B5	B4	B3	B2	B1	B0
Basic Colors	Black	0	0	0	0	0	0	0	0	0	0	0	0	0	0	0	0	0	0
	Red	1	1	1	1	1	1	0	0	0	0	0	0	0	0	0	0	0	0
	Green	0	0	0	0	0	0	1	1	1	1	1	1	0	0	0	0	0	0
	Blue	0	0	0	0	0	0	0	0	0	0	0	0	1	1	1	1	1	1
	Cyan	0	0	0	0	0	0	1	1	1	1	1	1	1	1	1	1	1	1
	Magenta	1	1	1	1	1	1	0	0	0	0	0	0	1	1	1	1	1	1
	Yellow	1	1	1	1	1	1	1	1	1	1	1	1	0	0	0	0	0	0
	White	1	1	1	1	1	1	1	1	1	1	1	1	1	1	1	1	1	1
Gray Scale of Red	Red(0) / Dark	0	0	0	0	0	0	0	0	0	0	0	0	0	0	0	0	0	0
	Red(1)	0	0	0	0	0	1	0	0	0	0	0	0	0	0	0	0	0	0
	Red(2)	0	0	0	0	1	0	0	0	0	0	0	0	0	0	0	0	0	0
	:	:	:	:	:	:	:	:	:	:	:	:	:	:	:	:	:	:	:
	:	:	:	:	:	:	:	:	:	:	:	:	:	:	:	:	:	:	:
	Red(61)	1	1	1	1	0	1	0	0	0	0	0	0	0	0	0	0	0	0
	Red(62)	1	1	1	1	1	0	0	0	0	0	0	0	0	0	0	0	0	0
	Red(63)	1	1	1	1	1	1	0	0	0	0	0	0	0	0	0	0	0	0
Gray Scale of Green	Green(0)/ Dark	0	0	0	0	0	0	0	0	0	0	0	0	0	0	0	0	0	0
	Green(1)	0	0	0	0	0	0	0	0	0	0	0	1	0	0	0	0	0	0
	Green(2)	0	0	0	0	0	0	0	0	0	0	1	0	0	0	0	0	0	0
	:	:	:	:	:	:	:	:	:	:	:	:	:	:	:	:	:	:	:
	:	:	:	:	:	:	:	:	:	:	:	:	:	:	:	:	:	:	:
	Green(61)	0	0	0	0	0	0	1	1	1	1	0	1	0	0	0	0	0	0
	Green(62)	0	0	0	0	0	0	1	1	1	1	1	0	0	0	0	0	0	0
	Green(63)	0	0	0	0	0	0	1	1	1	1	1	1	0	0	0	0	0	0
Gray Scale of Blue	Blue(0)/ Dark	0	0	0	0	0	0	0	0	0	0	0	0	0	0	0	0	0	0
	Blue (1)	0	0	0	0	0	0	0	0	0	0	0	0	0	0	0	0	0	1
	Blue (2)	0	0	0	0	0	0	0	0	0	0	0	0	0	0	0	0	1	0
	:	:	:	:	:	:	:	:	:	:	:	:	:	:	:	:	:	:	:
	:	:	:	:	:	:	:	:	:	:	:	:	:	:	:	:	:	:	:
	Blue (61)	0	0	0	0	0	0	0	0	0	0	0	0	1	1	1	1	0	1
	Blue (62)	0	0	0	0	0	0	0	0	0	0	0	0	1	1	1	1	1	0
	Blue (63)	0	0	0	0	0	0	0	0	0	0	0	0	1	1	1	1	1	1

### Correspondence between Data and Display Position

	S0001	S0002	S0003	S0004	S0005	S0006	S0007	S0008	-----	S959	S960
C001	R001	G001	B001	R002	G002	B002	R003	G003		G320	B320
C234	R001	G001	B001	R002	G002	B002	R003	G003		G320	B320



## 9. OPTICAL CHARACTERISTIC

### 9-1. Specification:

Item	Symbol	Condition	Min.	Typ.	Max.	Unit	Remark
Response time	Rise	$\theta=0^\circ$	-	15	30	ms	Note 4,6
	Fall		Tf	-	20	40	
Contrast ratio	CR	At optimized viewing angle	300	400			Note 5,6
Viewing angle	Top	$CR \geq 10$	10	20	-	Deg.	Note 6,7
	Bottom		30	40	-		
	Left		45	50	-		
	Right		45	50	-		
Brightness		$\theta=0^\circ$	450	500	--	$cd/m^2$	Note 8
Uniformity			80	85		%	
White chromaticity	X	$\theta=0^\circ$	0.25	0.30	0.35		Note 8
	y		0.30	0.35	0.40		

Measured by :TOPCON BM-7

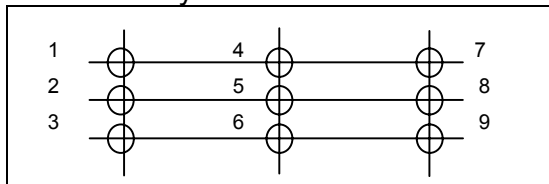

$$\text{Brightness} = \frac{1+2+3+4+5+6+7+8+9}{9}$$

Note 1~5: See next page.

Note 1: Ambient temperature =25°C. Lamp current  $I_L=6$  mArms.

Note 2: To be measured in the dark room.

Note 3: To be measured on the center area of panel with a viewing cone of  $1^\circ$  by Topcon luminance meter BM-7, after 10 minutes operation.

Note 4: Definition of response time:

The output signals of photo-detector are measured when the input signals are changed from "white" to "black"(rising time) and from "black" to "white"(falling time), respectively. The response time is defined as the time interval between the 10% and 90% of amplitudes. Refer to figure as shown below.

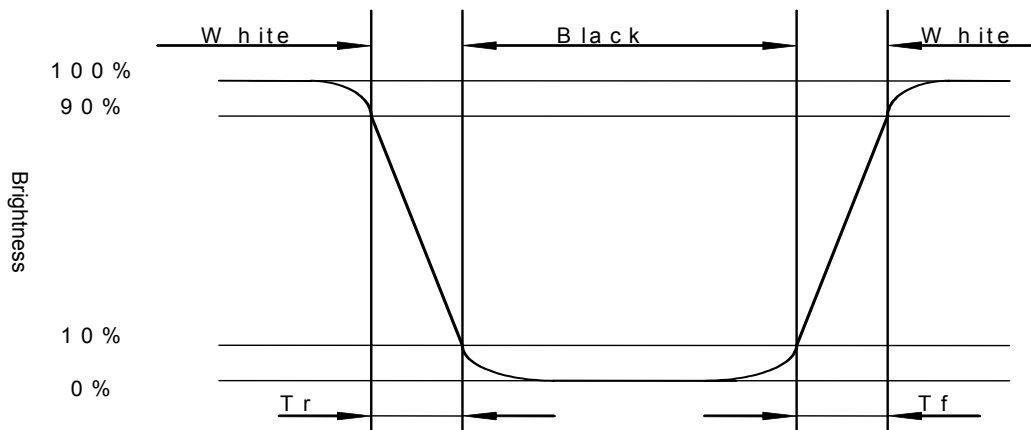
**Note5: Definition of contrast ratio:**

Contrast ratio is calculated with the following formula.

$$\text{Contrast ratio (CR)} = \frac{\text{Photo-detector output when LCD is at "White" state}}{\text{Photo-detector output when LCD is at "Black" state}}$$

Note 6. White  $V_i = V_{i50} \pm 1.5V$  Black  $V_i = V_{i50} \pm 2.0V$

" $\pm$ " means that the analog input signal swings in phase with COM signal.

" $\mp$ " means that the analog input signal swings out of phase with COM signal.

$V_{i50}$  : The analog input voltage when transmission is 50%

The 100% transmission is defined as the transmission of LCD panel when all the input terminals of module are electrically opened.

Note 7. Definition of viewing angle:

Refer to figure as below.

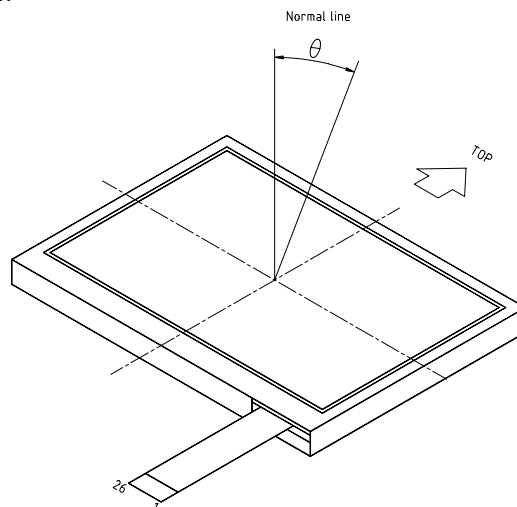

Note 8. Measured at the center area of the panel when all the input terminals of LCD panel are electrically opened.

## 10. QUALITY ASSURANCE

### 10.1 Test Condition

#### 10.1.1 Temperature and Humidity(Ambient Temperature)

Temperature :  $25 \pm 5^{\circ}\text{C}$

Humidity :  $65 \pm 5\%$

#### 10.1.2 Operation

Unless specified otherwise, test will be conducted under function state.

#### 10.1.3 Container

Unless specified otherwise, vibration test will be conducted to the product itself without putting it in a container.

#### 10.1.4 Test Frequency

In case of related to deterioration such as shock test. It will be conducted only once.

#### 10.1.5 Test Method

No.	Reliability Test Item & Level	Test Level
1	High Temperature Storage Test	T=80°C,240hrs
2	Low Temperature Storage Test	T=-40°C,240hrs
3	High Temperature Operation Test	T=70°C,240hrs
4	Low Temperature Operation Test	T=-20°C,240hrs
5	High Temperature and High Humidity Operation Test	T=60°C,90% RH,240hrs
6	Thermal Cycling Test (No operation)	-25°C → +25°C → +70°C,200 Cycles 30 min 5min 30 min
7	Vibration Test (No operation)	Frequency:0 ~ 55 Hz Amplitude:1.5 mm Sweep Time:11min Test Period:6 Cycles for each Direction of X,Y,Z
8	Electrostatic Discharge Test (No operation)	150pF,330Ω Air:± 15KV;Contact: ± 8KV 10 times/point;4 points/panel face

### 11. LOT NUMBERING SYSTEM

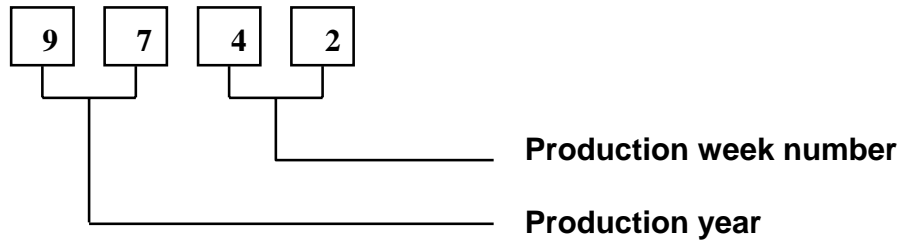

### 12. LCM NUMBERING SYSTEM

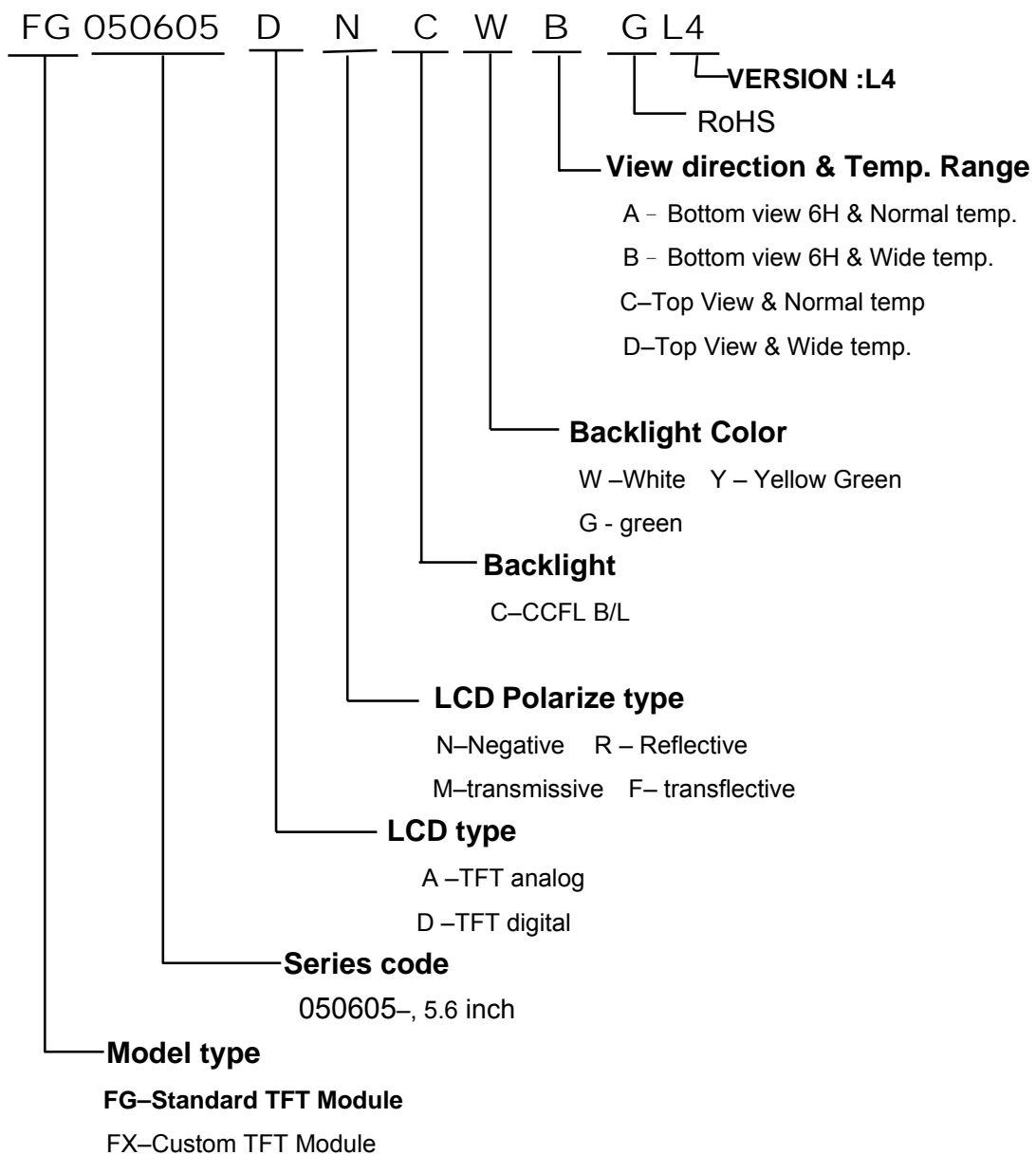

## 13. PRECAUTION FOR USING LCM

### 1. LIQUID CRYSTAL DISPLAY (LCD)

LCD is made up of glass, organic sealant, organic fluid, and polymer based polarizers. The following precautions should be taken when handling,

- (1). Keep the temperature within range of use and storage. Excessive temperature and humidity could cause polarization degradation, polarizer peel off or bubble.
- (2). Do not contact the exposed polarizers with anything harder than an HB pencil lead. To clean dust off the display surface, wipe gently with cotton, chamois or other soft material soaked in petroleum benzin.
- (3). Wipe off saliva or water drops immediately. Contact with water over a long period of time may cause polarizer deformation or color fading, while an active LCD with water condensation on its surface will cause corrosion of ITO electrodes.
- (4). Glass can be easily chipped or cracked from rough handling, especially at corners and edges.
- (5). Do not drive LCD with DC voltage.

### 2. Liquid Crystal Display Modules

#### 2.1 Mechanical Considerations

LCM are assembled and adjusted with a high degree of precision. Avoid excessive shocks and do not make any alterations or modifications. The following should be noted.

- (1). Do not tamper in any way with the tabs on the metal frame.
- (2). Do not modify the PCB by drilling extra holes, changing its outline, moving its components or modifying its pattern.
- (3). Do not touch the elastomer connector, especially insert an backlight panel (for example, EL).
- (4). When mounting a LCM make sure that the PCB is not under any stress such as bending or twisting. Elastomer contacts are very delicate and missing pixels could result from slight dislocation of any of the elements.
- (5). Avoid pressing on the metal bezel, otherwise the elastomer connector could be deformed and lose contact, resulting in missing pixels.

#### 2.2. Static Electricity

LCM contains CMOS LSI's and the same precaution for such devices should apply, namely

- (1). The operator should be grounded whenever he/she comes into contact with the module. Never touch any of the conductive parts such as the LSI pads, the copper leads on the PCB and the interface terminals with any parts of the human body.
- (2). The modules should be kept in antistatic bags or other containers resistant to static for storage.
- (3). Only properly grounded soldering irons should be used.
- (4). If an electric screwdriver is used, it should be well grounded and shielded from commutator sparks.

(5) The normal static prevention measures should be observed for work clothes and working benches; for the latter conductive (rubber) mat is recommended.

(6). Since dry air is inductive to statics, a relative humidity of 50-60% is recommended.

### 2.3 Soldering

- (1). Solder only to the I/O terminals.
- (2). Use only soldering irons with proper grounding and no leakage.
- (3). Soldering temperature :  $280^{\circ}\text{C} \pm 10^{\circ}\text{C}$
- (4). Soldering time: 3 to 4 sec.
- (5). Use eutectic solder with resin flux fill.
- (6). If flux is used, the LCD surface should be covered to avoid flux spatters. Flux residue should be removed after wards.

### 2.4 Operation

- (1). The viewing angle can be adjusted by varying the LCD driving voltage  $V_0$ .
- (2). Driving voltage should be kept within specified range; excess voltage shortens display life.
- (3). Response time increases with decrease in temperature.
- (4). Display may turn black or dark blue at temperatures above its operational range; this is (however not pressing on the viewing area) may cause the segments to appear "fractured".
- (5). Mechanical disturbance during operation (such as pressing on the viewing area) may cause the segments to appear "fractured".

### 2.5 Storage

If any fluid leaks out of a damaged glass cell, wash off any human part that comes into contact with soap and water. Never swallow the fluid. The toxicity is extremely low but caution should be exercised at all the time.

### 2.6 Limited Warranty

Unless otherwise agreed between DATA IMAGE and customer, DATA IMAGE will replace or repair any of its LCD and LCM which is found to be defective electrically and visually when inspected in accordance with DATA IMAGE acceptance standards, for a period on one year from date of shipment. Confirmation of such date shall be based on freight documents. The warranty liability of DATA IMAGE is limited to repair and/or replacement on the terms set forth above. DATA IMAGE will not responsible for any subsequent or consequential events.

Confidential Document  
**14. OUTLINE DRAWING**

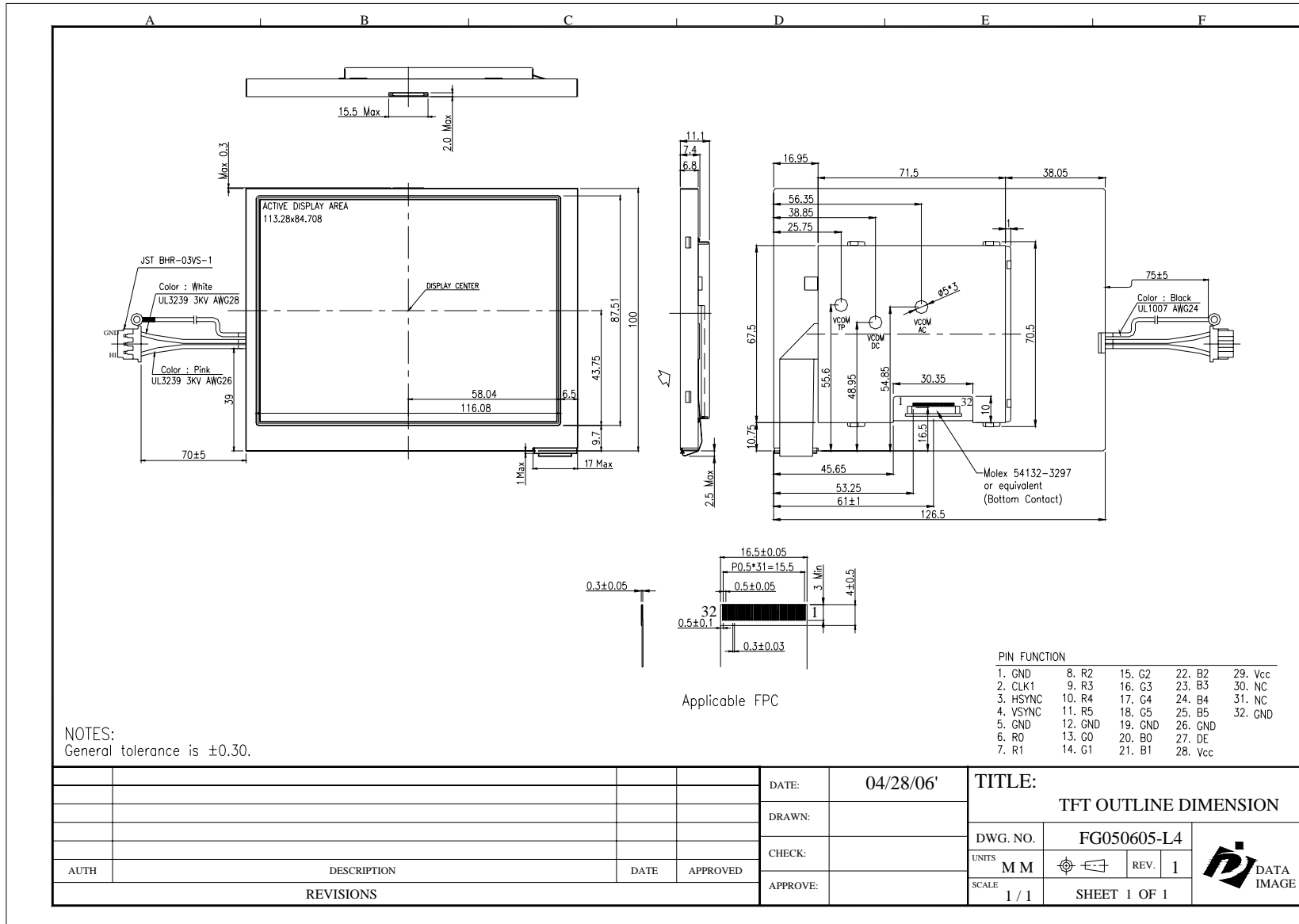

## 15. PACKAGE INFORMATION

FG050605C (162g) = 162 x 40 = 6480 g  
 Antistatic tray (138g)=138 x 10 = 1380 g  
 Carton+Form+Antistatic Form+Drier = 8900 g

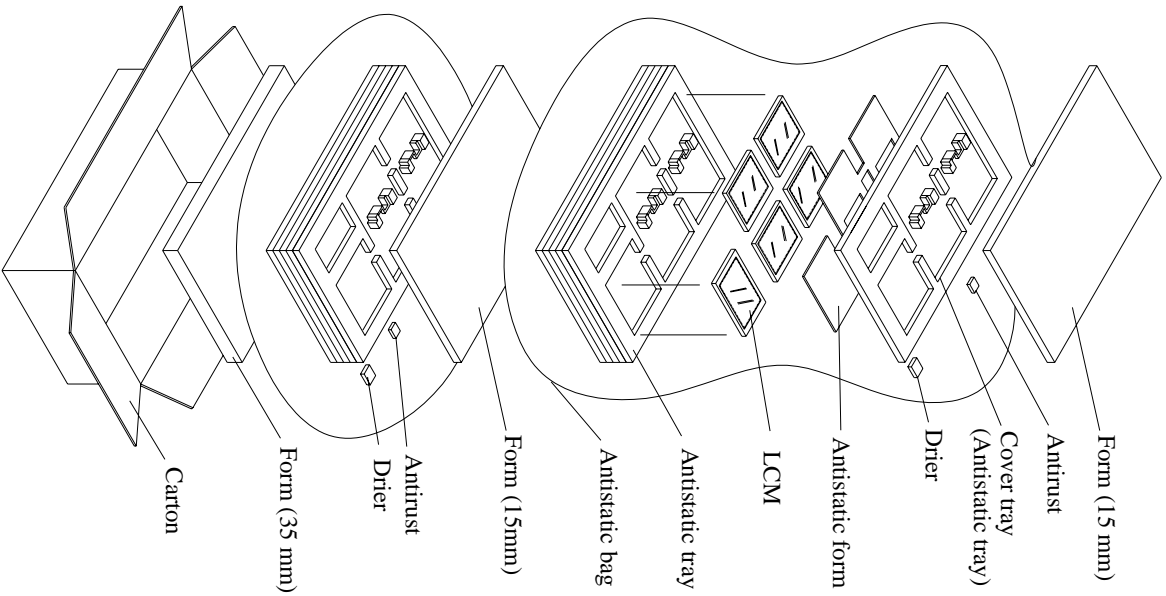

### Material

1 Carton + 2 Anti-static bag + 1 Form(35mm\*1、15mm\*2) + 10 Anti-static tray

### Total pcs

- 1 Antistatic tray = 5 pcs
- 1 Anti-static bag = 4 Anti-static tray + cover tray = 4\*5 + 0 = 20 pcs
- 1 Carton = 2 Anti-static bag = 2\*20 = 40 pcs
- 1 Carton = 40pcs

Carton size : 482L x 282W x 279H (mm)

Total Weight ÷ 8.9 kgw

**5.6" TFT LCM PACKING**