



Chunghwa Picture Tubes, Ltd.

Technical Specification

Date : 2007/02/06

CPT TFT-LCD

CLAA150XP07FQ Y

ACCEPTED BY :

APPROVED BY	CHECKED BY	PREPARED BY
周廷縣	溫文良	Product Planning Management General Division

Prepared by: Product Planning management General Division

CHUNGHWA PICTURE TUBES, LTD.

1127 Hopin Rd., Padeh, Taoyuan, Taiwan 334, R.O.C.

TEL: +886-3-3675151 FAX: +886-3-377-3001

Doc.No:	CLAA150XP07FQ Y--SPEC-Ver1.0-20070206	Issue Date:	2007/02/06
---------	---------------------------------------	-------------	------------

T- 3650002- 000- A NEW

RECORD OF REVISIONS

Revision No.	Date	Page	Description
NEW	2006/11/29	--	The first edition issued.

CONTENTS

No	Item	Page
1	OVERVIEW	3
2	ABSOLUTE MAXIMUM RATINGS	4
3	ELECTRICAL CHARACTERISTICS	6
4	INTERFACE PIN CONNECTION	10
5	INTERFACE TIMING	11
6	DATA MAPPING	12
7	COLOR DATA ASSIGNMENT	13
8	BLOCK DIAGRAM	14
9	MECHANICAL SPECIFICATION	15
10	OPTICAL CHARACTERISTICS	17
11	RELIABILITY TEST CONDITIONS	19
12	HANDLING PRECAUTIONS FOR TFT-LCD MODULE	20

1. OVERVIEW

CLAA150XP07FQ is 15" color TFT-LCD (Thin Film Transistor Liquid Crystal Display) module composed of LCD panel, LVDS driver ICs, control circuit and backlight. By applying 8 bit digital data (6bit + FRC), 1024*768, 16.2M-color images are displayed on the 15" diagonal screen. General specification are summarized in the following table:

ITEM	SPECIFICATION
Display Area (mm)	304.1(H) x 228.1(V) (15.0-inch diagonal)
Number of Pixels	1024 (H) x 768(V)
Pixel Pitch (mm)	0.297(H) x 0.297(V)
Color Pixel Arrangement	RGB vertical stripe
Display Mode	Normally white, TN
Number of Colors	16.2M (6bit + FRC)
Brightness (cd/m ²)	450cd/m ² (Typ.) (center, 6.5mA)
Viewing Angle	140 / 125 (Typ.)
Wide Viewing Angle Technology	Optical Compensation Film
Surface Treatment	Anti-glare
Response Time	8 ms (Typ.)
Color Saturation	65 %
Total Module Power (W)	16.64+ 1.8 (Typ.)
Optimum Viewing Angle	6 o'clock
Module Size (mm)	326.5(W) x 253.5(H) x 14.0(D) (Typ.)
Module Weight (g)	1300 (Typ.)
Backlight Unit	CCFL, 4 tables, edge-light (top/ bottom)

The LCD Products listed on this document are not suitable for use of aerospace equipment, submarine cables, and nuclear reactor control system and life support systems. If customers intend to use these LCD products for above application or not listed in "Standard" as follows, please contact our sales people in advance.

Standard: Computer, Office equipment, Communication equipment, Test and Measurement equipment, Machine tool, Industrial robot, Audio & Visual equipment, and other consumer products.

2. ABSOLUTE MAXIMUM RATINGS

The following are maximum values which, if exceeded, may cause faulty operation or damage to the unit.

ITEM	SYMBOL	MIN.	MAX.	UNIT	Remark
Power Supply Voltage For LCD	VCC	--	4.0	V	--
IDDD Rush Current	IRUSHd	--	4.0	A	*1)
Lamp Voltage	VL	495	605	Vrms	*2)
Lamp Current	IL	3.5	8	mArms	*2)
Lamp Frequency	FL	40	80	kHz	*2)*3)
Operation Temperature (Surrounding)	T _{op}	0	50	°C	*4), 5), 6), 7)
Storage Temperature	T _{stg}	-20	60	°C	*4), 5), 6)
Delayed Discharge Time	TD	--	1	sec	*8)

[Note]

*1) The rising time of VCC is 550 μ sec (measured conditions are described below), If VCC rise time increase then I_{RUSH} decrease.

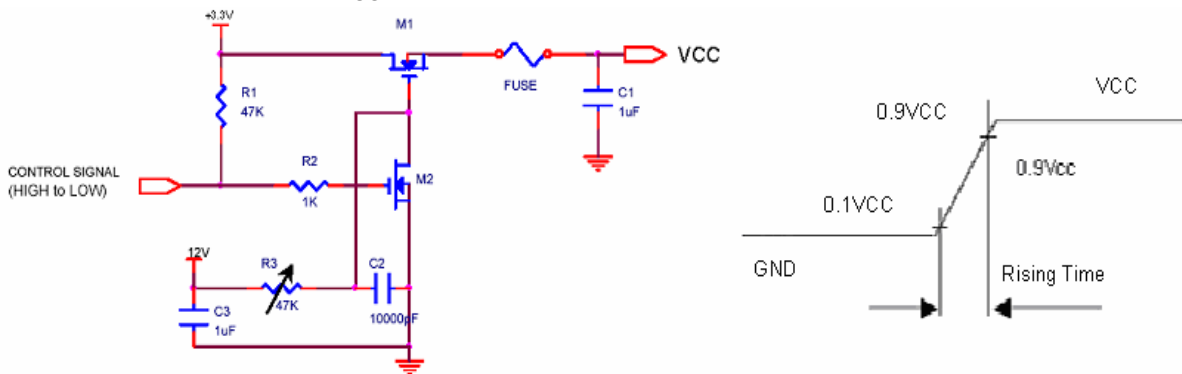

- *2) These are properties of single lamp(without backlight).
 - a. Lamp life-time relate to the lamp current, please operate following statement Back light system at page 7.
 - b. When lamp current over the definition of absolute max. value , life-time of the product will decay rapidly or operate unusual.
- *3) The frequency range will not affect to lamp life and reliability characteristics.
 - a. Electrical and optical characteristics will display well at 40~60 kHz frequency.
 - b. It would not damage the lifetime and reliability of the panel at 40~80 kHz frequency.
- *4) The relative temperature and humidity range are as below sketch, 90%RHMax, Ta \leq 40°C.
- *5) The maximum wet bulb temperature \leq 39°C (Ta > 40°C) and without dewing.
- *6) If you use the product in a environment which over the definition of temperature and humidity too long to effect the result of eye-atching.
- *7) Delay lighting testing needs the volt above start voltage Vrms. Before the procedure tube needs typical lighting for 1 min. and stay in the temperature 25 \pm 2 °C for 24 hours and then testing in the same condition in dark room.
 - Humidity \leq 85%RH without condensation. Relative Humidity \leq 90% (Ta \leq 40°C)
 - Wet Bulb Temperature \leq 39°C (Ta \geq 40°C)

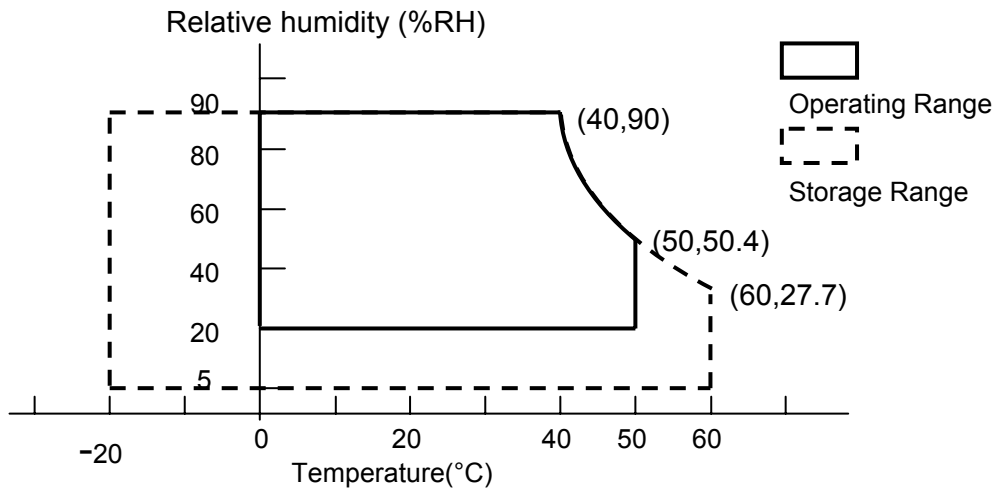

3. ELECTRICAL CHARACTERISTICS

3.1 TFT-LCD

Ta=25°C

ITEM	SYMBOL	MIN	TYP	MAX	UNIT	REMARK
Power Supply Voltage for Logic	VCC	3.0	3.3	3.6	V	*1)
Power Supply Current for Logic	ICC	--	450	600	mA	*2)
Permissible Ripple Voltage for Logic	VRPd	--	--	100	mVp-p	Vin=+3.3V
Differential impedance	Zm	70	100	110	Ω	*3)

[Note]

*1)Power and data sequence

0.5ms	t1	10ms	500ms	t4
0	t2	50ms	200ms	t5
0	t3	50ms	200ms	t6

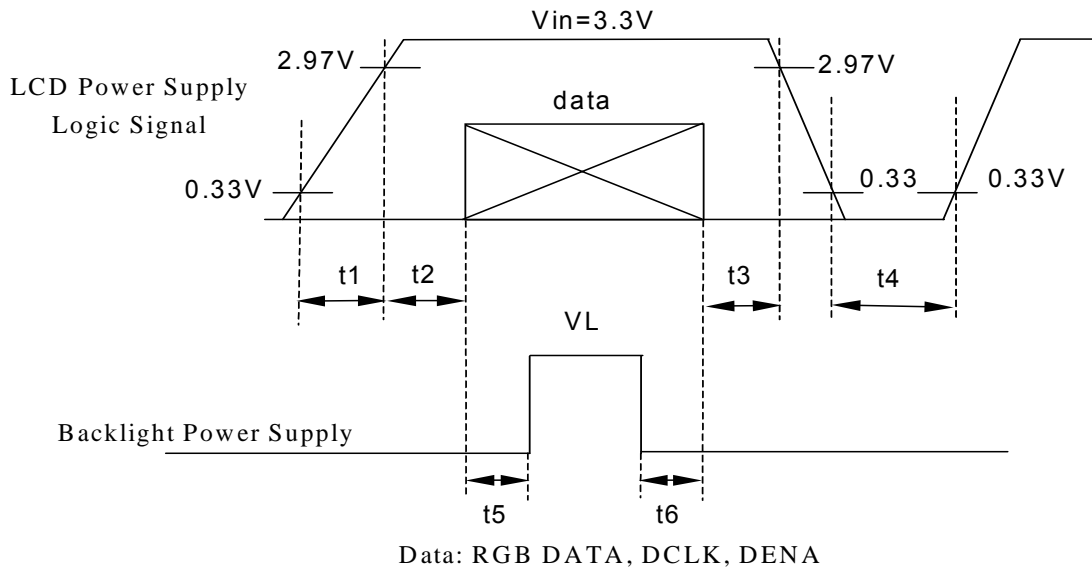

VCC-dip state:

- 1) When $2.7\text{ V} \leq VCC < 3.0\text{V}$, $t_d \leq 10\text{ ms}$.
- 2) **When $VCC < 2.7\text{V}$, it will reset the power**, VCC-dip condition should also follow the VCC-turn-off condition.

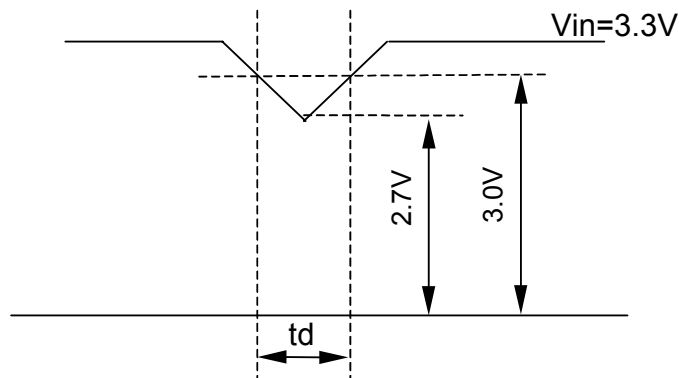

*2) Typical current situation: 0~255-gray-bar pattern,

- Typical value is measured when displaying horizontal gray scale Pattern:0~63 gray level 768 line mode, VCC=+3.3V, f_{CLK}=65 MHz.

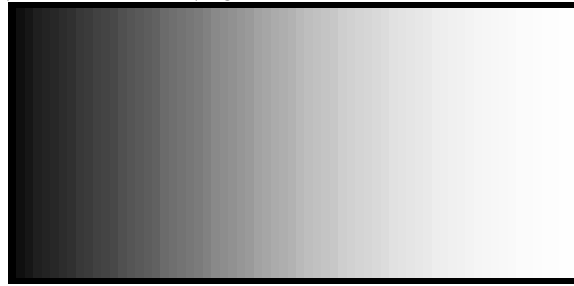

- Max. value: 768 line mode, VCC= +3.3V, f_{CLK}=65 MHz

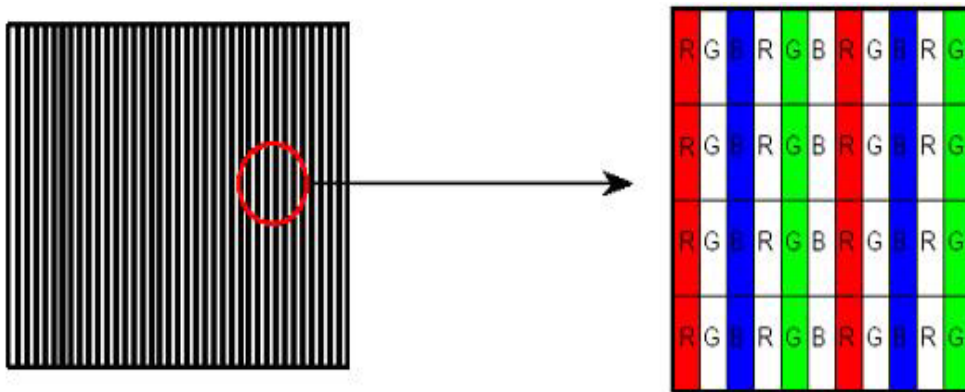

*3) Definition of the LVDS data

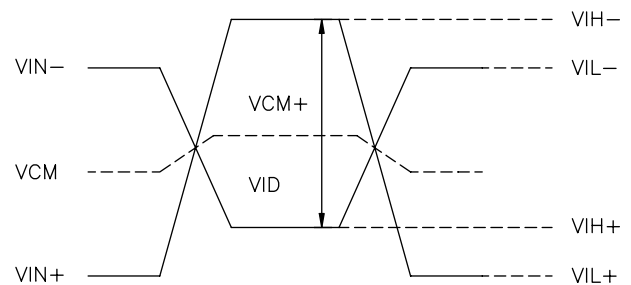
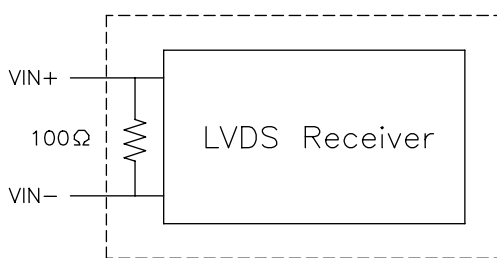

$$\begin{aligned}
 &VID = VIN_+ - VIN_- \\
 &\Delta VCM = |VIN_+ - VCM_-| \\
 &\Delta VID = |VIN_+ - VID_-| \\
 &VID_+ = |VIN_+ - VIH_-| \\
 &VID_- = |VIN_+ - VIL_-| \\
 &VCM = (VIN_+ + VIN_-)/2 \\
 &VCM_+ = (VIN_+ + VIH_-)/2 \\
 &VCM_- = (VIN_+ + VIL_-)/2
 \end{aligned}$$

VIN+: Positive differential DATA & CLK input
 VIN- : Negative differential DATA & CLK input

3.2 Backlight

(a) Electrical Characteristics

Ta=25°C

ITEM	SYMBOL	MIN	TYP	MAX	UNIT	REMARK
Lamp Voltage	VL	576	640	704	Vrms	*1);IL=6.5mA
Lamp Current	IL	6.0	6.5	7.0	mArms	*2)
Inverter Frequency	FI	40		80	kHz	*1)*3) *4)
Starting Lamp Voltage	VS		—	950	Vrms	Ta=25°C *1)*5)
			—	1100	Vrms	Ta=0°C *1)*5)

(b) Lamp Life Time

ITEM	IL @3.0 mA	IL @6.5 mA	IL @8.0 mA	UNIT	REMARK
Lamp Life Time	--	Min. 50,000	Min.40,000	hr	Continuous Operation *6)
Turn-on and Turn-off Operation	--	Min.100,000	--	time	Continuous Operation *7)

[Note] If the waveform of light up-driving is asymmetric, the distribution of mercury inside the lamp tube will become unequal or will deplete the Ar gas in it. Then it may cause the abnormal phenomenon when lighting the lamp up. Therefore, designers have to try their best to fulfill the conditions under the inverter designing-stage as below:

- The degrees of unbalance: $< 10\%$
- The ratio of wave height: $< \sqrt{2} \pm 10\%$

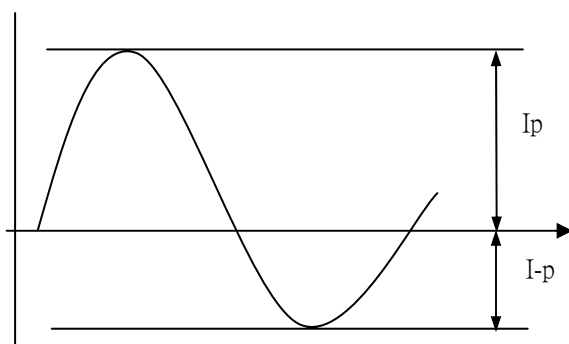

Ip: high side peak

I-p: low side peak

A: The degrees of unbalance = $| I_p - I-p | / I_{rms} \times 100 (\%)$

B: The ratio of wave height = $I_p \text{ (or } I-p) / I_{rms}$

- *1) These are properties of single lamp(without backlight).
 *2) Lamp Current measurement method (The current meter is inserted in cold line)

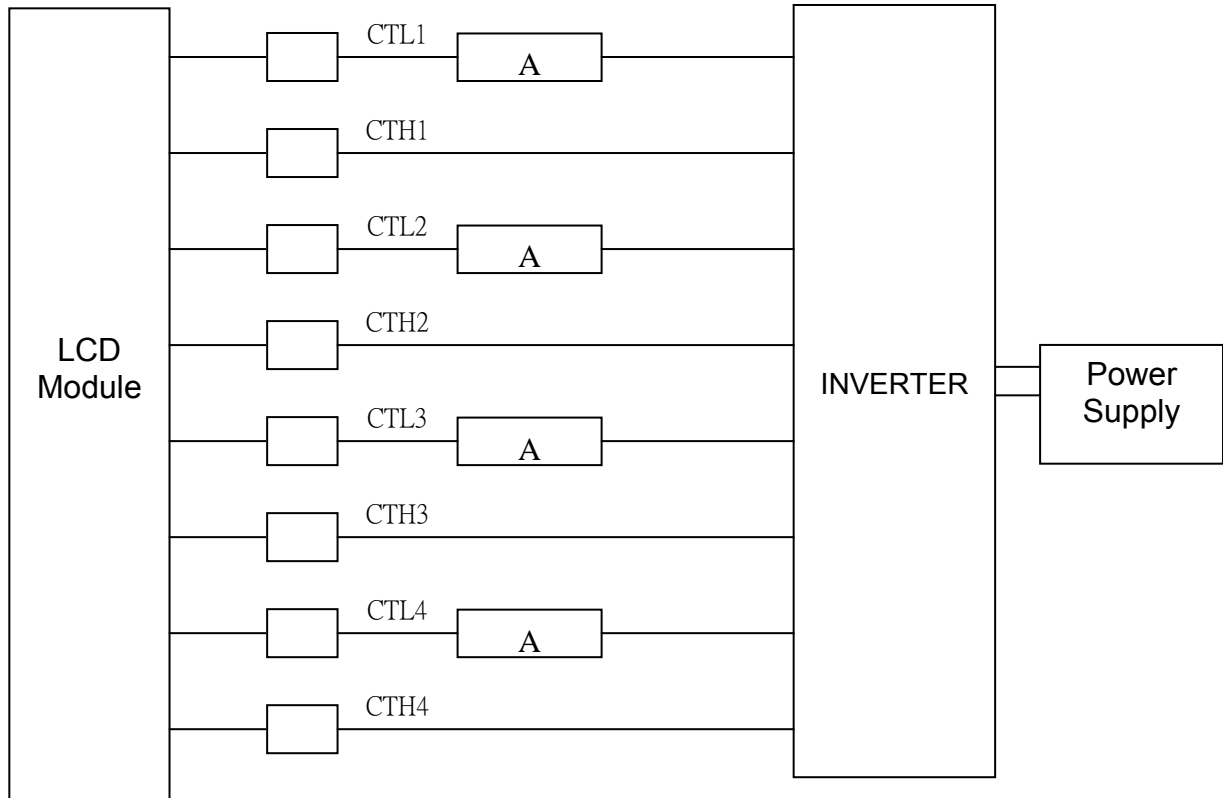

- *3) The frequency range can be kept within +/- 10% range of electrical and optical characteristics.
- *4) Lamp frequency of inverter may produce interference with horizontal synchronous frequency, and this may cause horizontal beat on the display. Therefore, please adjust lamp frequency, and keep inverter as far from module as possible or use electronic shielding between inverter and module to avoid the interference.
- *5) The maximum value of starting lamp voltage is defined as the probably biggest value of starting lamp voltage, hence the design of starting lamp voltage for inverter must be equal to or higher than maximum starting lamp voltage.
- *6) Definition of the lamp life time :
- Luminance reduced to 50% of initial value.
 - When lamp current over 8.0mA, lamp life time will drop rapidly. If over 8.0mA, it will come up safety issue. If it lower than 3.5mA, the lamp will be damaged.
- *7) The condition of Turn-on and Turn-off operation is as below:
- Lamp current is 8mA. $T_a = 25 \pm 5 \text{ }^\circ\text{C}$.
 - Frequency is 10 sec.(on)/10 sec.(off)
 - Repeat it for 100 thousand times
 - The lamp life time still match the definition*6)

4. INTERFACE PIN CONNECTION

4.1 CN1

Outlet connector: **MSB240420 (STM) or equivalent**

Plug connector: **DF14-20S-1.25C (Hirose) or equivalent**

PIN NO.	SYMBOL	FUNCTION
1	VCC	+3.3V Power Supply
2	VCC	+3.3V Power Supply
3	GND	GND
4	GND	GND
5	RXIN0-	Negative LVDS Differential Data Input
6	RXIN0+	Positive LVDS Differential Data Input
7	GND	GND
8	RXIN1-	Negative LVDS Differential Data Input
9	RXIN1+	Positive LVDS Differential Data Input
10	GND	GND
11	RXIN2-	Negative LVDS Differential Data Input
12	RXIN2+	Positive LVDS Differential Data Input
13	GND	GND
14	RXCLK IN-	Negative LVDS Differential Clock Input
15	RXCLK IN+	Positive LVDS Differential Clock Input
16	GND	GND
17	RXIN3-	Negative LVDS Differential Data Input
18	RXIN3+	Positive LVDS Differential Data Input
19	GND	GND
20	NC	Reserved

- 1) Keep the NC Pin and don't connect it to GND or other signals.
- 2) GND Pin must connect to the ground, don't let it be a vacant pin.

4.2 CN2,3,4,5 (BACKLIGHT)

Backlight-side connector: **BDMR-02VS-1 (JST)**

Inverter-side connector: **SM02-BDS-3 (JST)**

CN2

PIN No.	SYMBOL	FUNCTION
1	CTH1~4	High Voltage
2	CTL1~4	Low Voltage

5. INTERFACE TIMING

5.1 Horizontal signal:

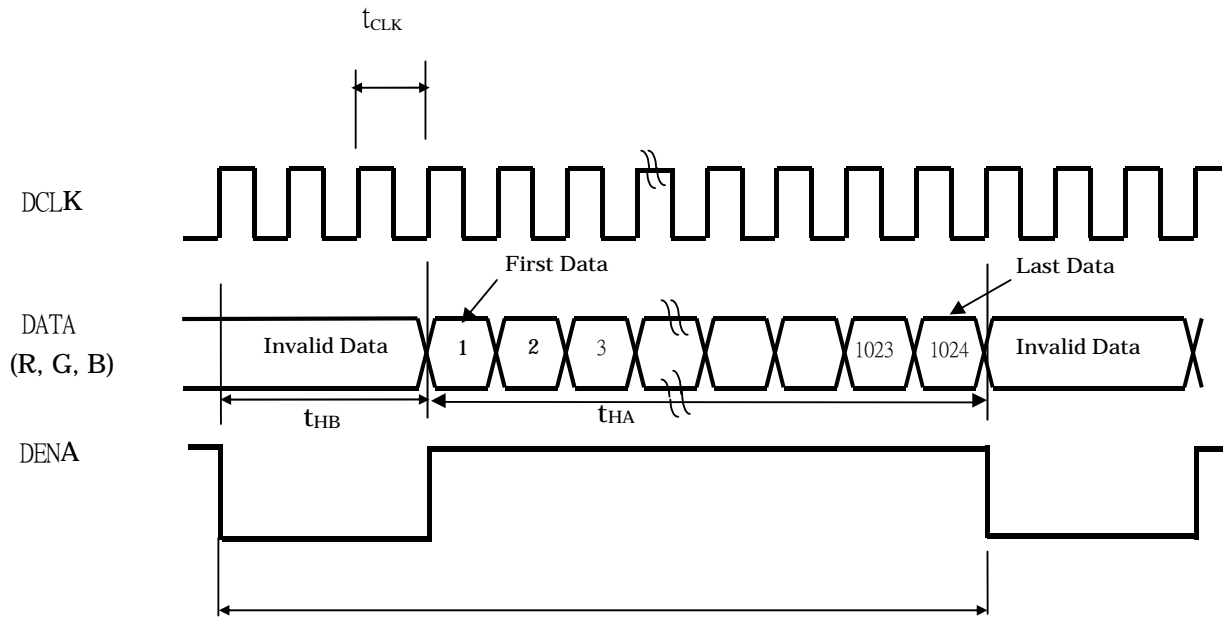

5.2 Vertical signal:

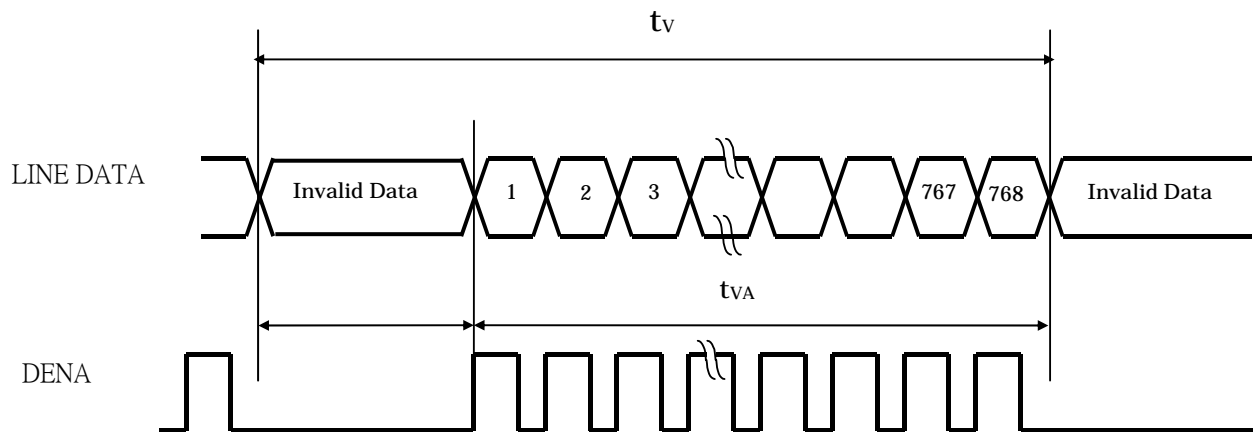

5.3 Timing Chart

ITEM		SYMBOL	MIN.	TYP.	MAX.	UNIT		
LCD Timing	DCLK	Freq.	f_{CLK}	41	65	80	MHz	
		Cycle	t_{CLK}	12.5	15.3	24	ns	
	DENA	Horizontal	Vertical line Rate	f_H	35.73	48.36	58.39	kHz
			Horizontal total time	t_H	1150	1344	1370	t_{CLK}
			Horizontal effective time	t_{HA}	--	1024	--	t_{CLK}
			Horizontal blank time	t_{HB}	126	320	346	t_{CLK}
		Vertical	Vertical frame Rate	Fr	45	60	75	Hz
			Vertical total time	t_V	794	806	860	t_H
			Vertical effective time	t_{VA}	--	768	--	t_H
			Vertical blank time	t_{VB}	26	38	92	t_H

Note: PAL specification (frame rate 47~53 Hz) and NTSC specification (frame rate 57~63 Hz) were conformed.

6. DATA MAPPING

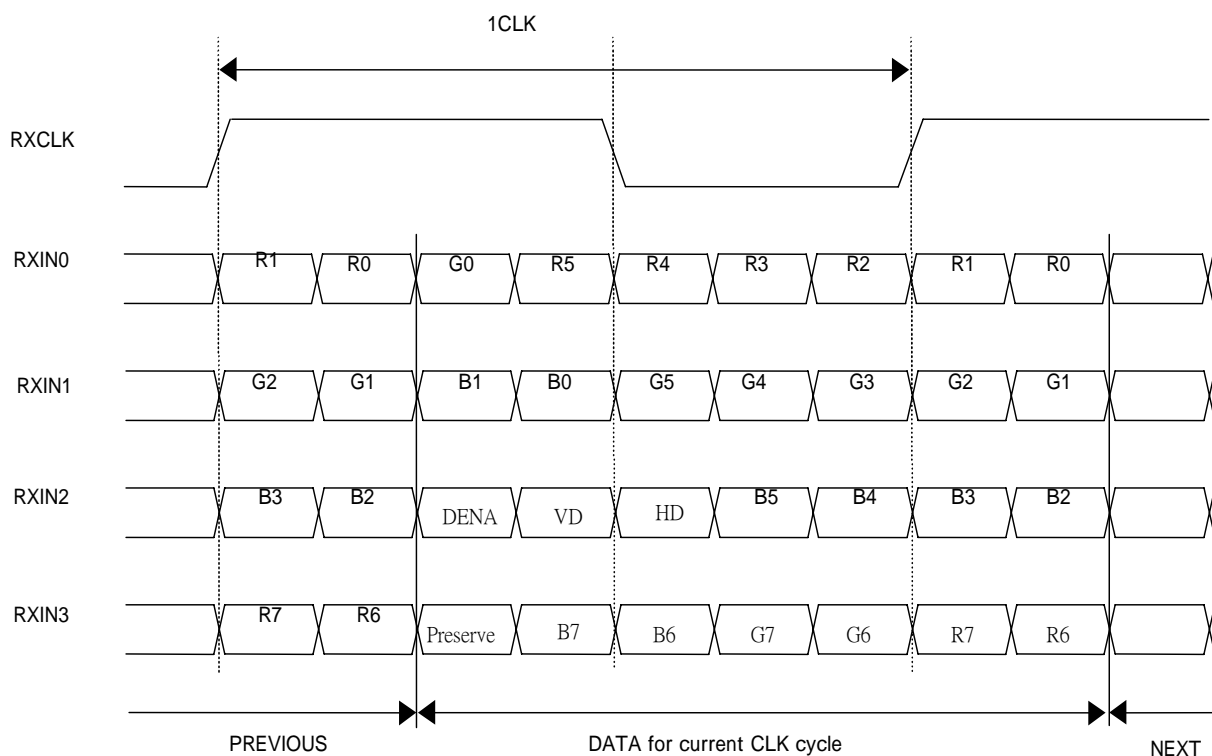

7. COLOR DATA ASSIGNMENT

Color	Input Data	MSB								LSB								MSB								LSB							
		R7	R6	R5	R4	R3	R2	R1	R0	G7	G6	G5	G4	G3	G2	G1	G0	B7	B6	B5	B4	B3	B2	B1	B0								
Basic Color	Black	0	0	0	0	0	0	0	0	0	0	0	0	0	0	0	0	0	0	0	0	0	0	0	0								
	Red	1	1	1	1	1	1	1	1	0	0	0	0	0	0	0	0	0	0	0	0	0	0	0	0								
	Green	0	0	0	0	0	0	0	0	1	1	1	1	1	1	1	1	0	0	0	0	0	0	0	0								
	Blue	0	0	0	0	0	0	0	0	0	0	0	0	0	0	0	0	1	1	1	1	1	1	1	1								
	Cyan	0	0	0	0	0	0	0	0	1	1	1	1	1	1	1	1	1	1	1	1	1	1	1	1								
	Magenta	1	1	1	1	1	1	1	1	0	0	0	0	0	0	0	0	1	1	1	1	1	1	1	1								
	Yellow	1	1	1	1	1	1	1	1	1	1	1	1	1	1	1	1	0	0	0	0	0	0	0	0								
	White	1	1	1	1	1	1	1	1	1	1	1	1	1	1	1	1	1	1	1	1	1	1	1	1								
Red	Red (0)	0	0	0	0	0	0	0	0	0	0	0	0	0	0	0	0	0	0	0	0	0	0	0	0								
	Red (1)	0	0	0	0	0	0	0	1	0	0	0	0	0	0	0	0	0	0	0	0	0	0	0	0								
	Red (2)	0	0	0	0	0	0	1	0	0	0	0	0	0	0	0	0	0	0	0	0	0	0	0	0								
	Red (254)	1	1	1	1	1	1	1	0	0	0	0	0	0	0	0	0	0	0	0	0	0	0	0	0								
	Red (255)	1	1	1	1	1	1	1	1	0	0	0	0	0	0	0	0	0	0	0	0	0	0	0	0								
Green	Green (0)	0	0	0	0	0	0	0	0	0	0	0	0	0	0	0	0	0	0	0	0	0	0	0	0								
	Green (1)	0	0	0	0	0	0	0	0	0	0	0	0	0	0	0	1	0	0	0	0	0	0	0	0								
	Green (2)	0	0	0	0	0	0	0	0	0	0	0	0	0	0	1	0	0	0	0	0	0	0	0	0								
	Green (254)	0	0	0	0	0	0	0	0	1	1	1	1	1	1	1	0	0	0	0	0	0	0	0	0								
	Green (255)	0	0	0	0	0	0	0	0	1	1	1	1	1	1	1	1	0	0	0	0	0	0	0	0								
Blue	Blue (0)	0	0	0	0	0	0	0	0	0	0	0	0	0	0	0	0	0	0	0	0	0	0	0	0								
	Blue (1)	0	0	0	0	0	0	0	0	0	0	0	0	0	0	0	0	0	0	0	0	0	0	0	1								
	Blue (2)	0	0	0	0	0	0	0	0	0	0	0	0	0	0	0	0	0	0	0	0	0	0	1	0								
	Blue (254)	0	0	0	0	0	0	0	0	0	0	0	0	0	0	0	0	1	1	1	1	1	1	1	0								
	Blue (255)	0	0	0	0	0	0	0	0	0	0	0	0	0	0	0	0	1	1	1	1	1	1	1	1								

[Note]

- 1) Definition of gray scale:
 Color (n): n indicates gray scale level; higher n means brighter level.
- 2) Data: 1-High, 0-Low.

8. BLOCK DIAGRAM

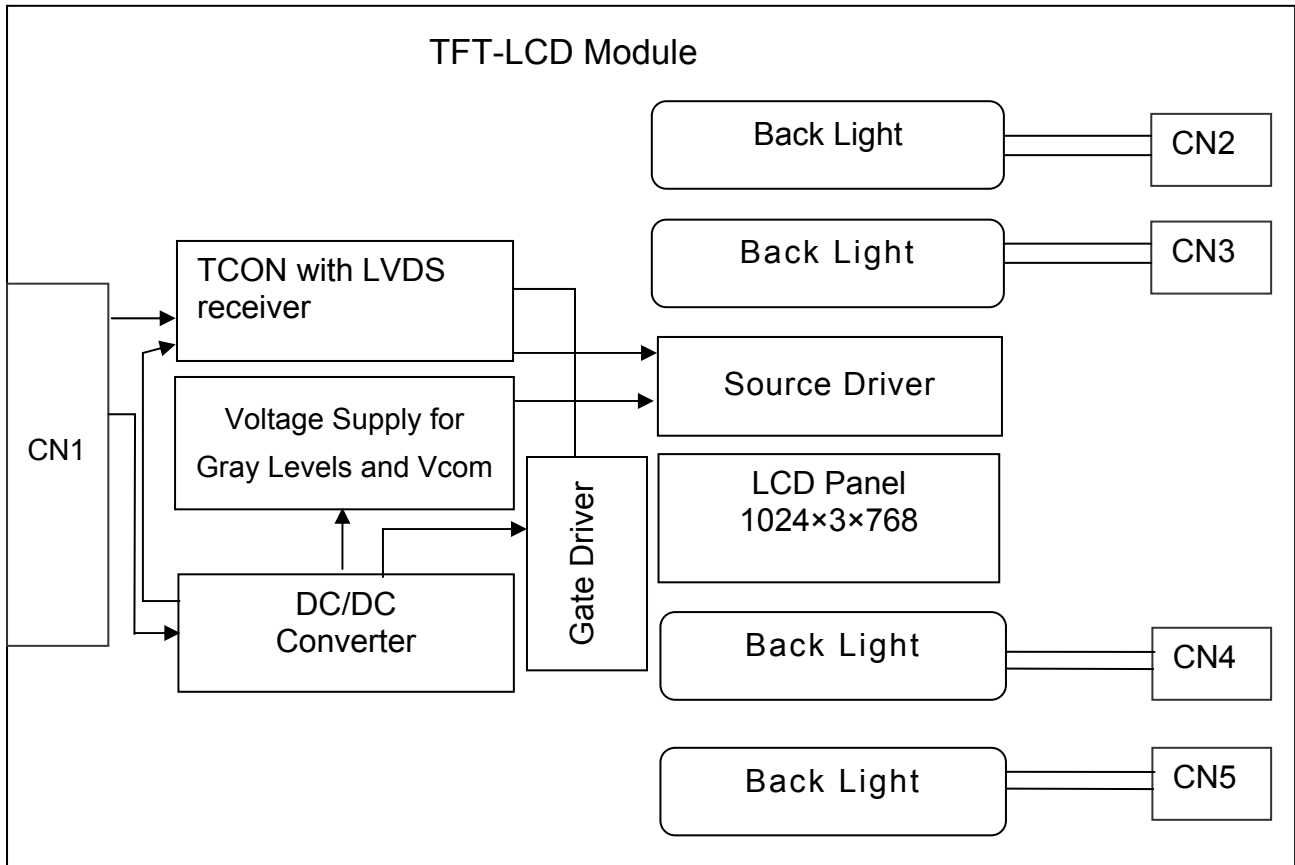

9. MECHANICAL SPECIFICATION

9.1 Front side (Tolerance is $\pm 0.5\text{mm}$ unless noted)

[Unit: mm]

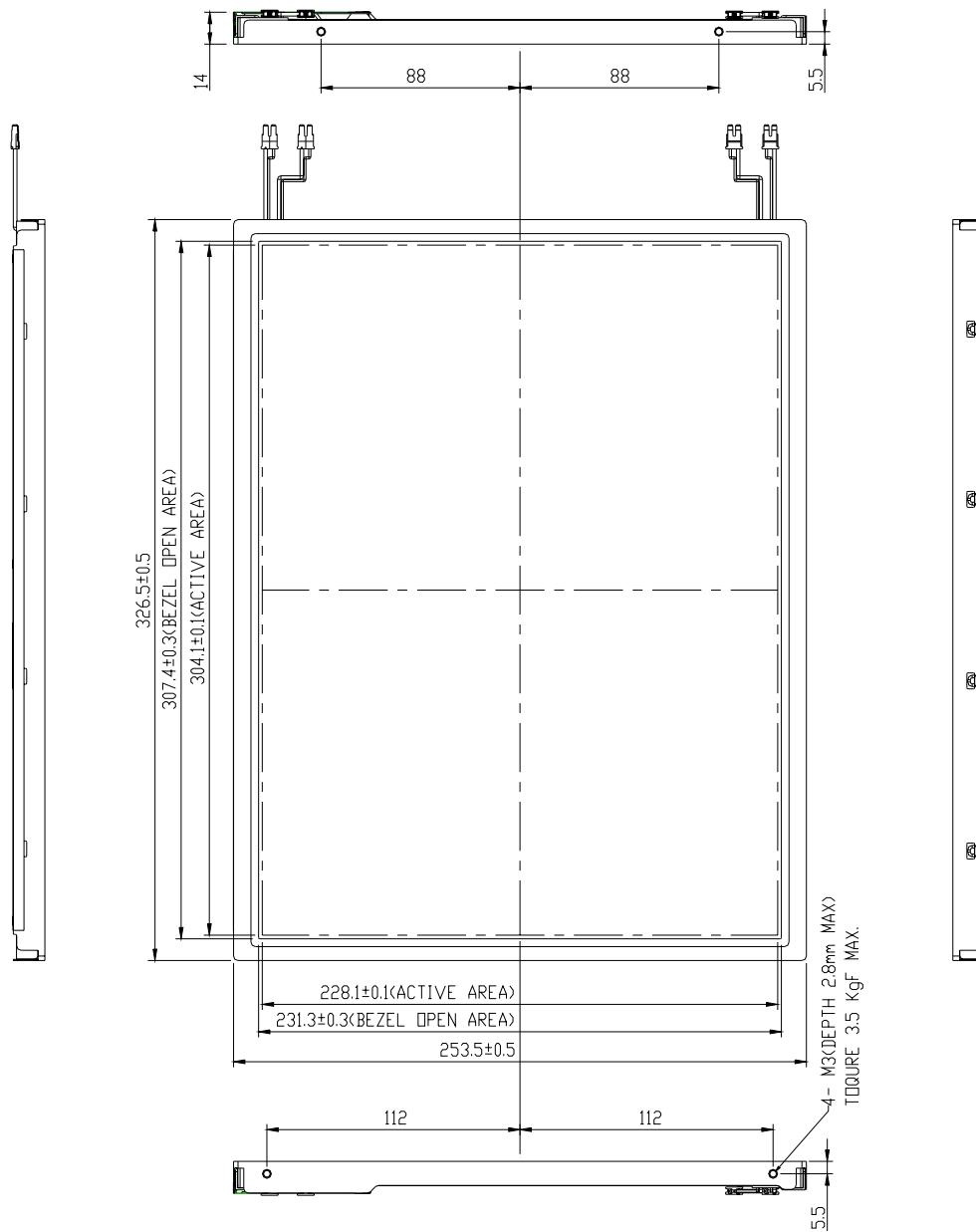

9.2 Rear side (Tolerance is $\pm 0.5\text{mm}$ unless noted)

[Unit: mm]

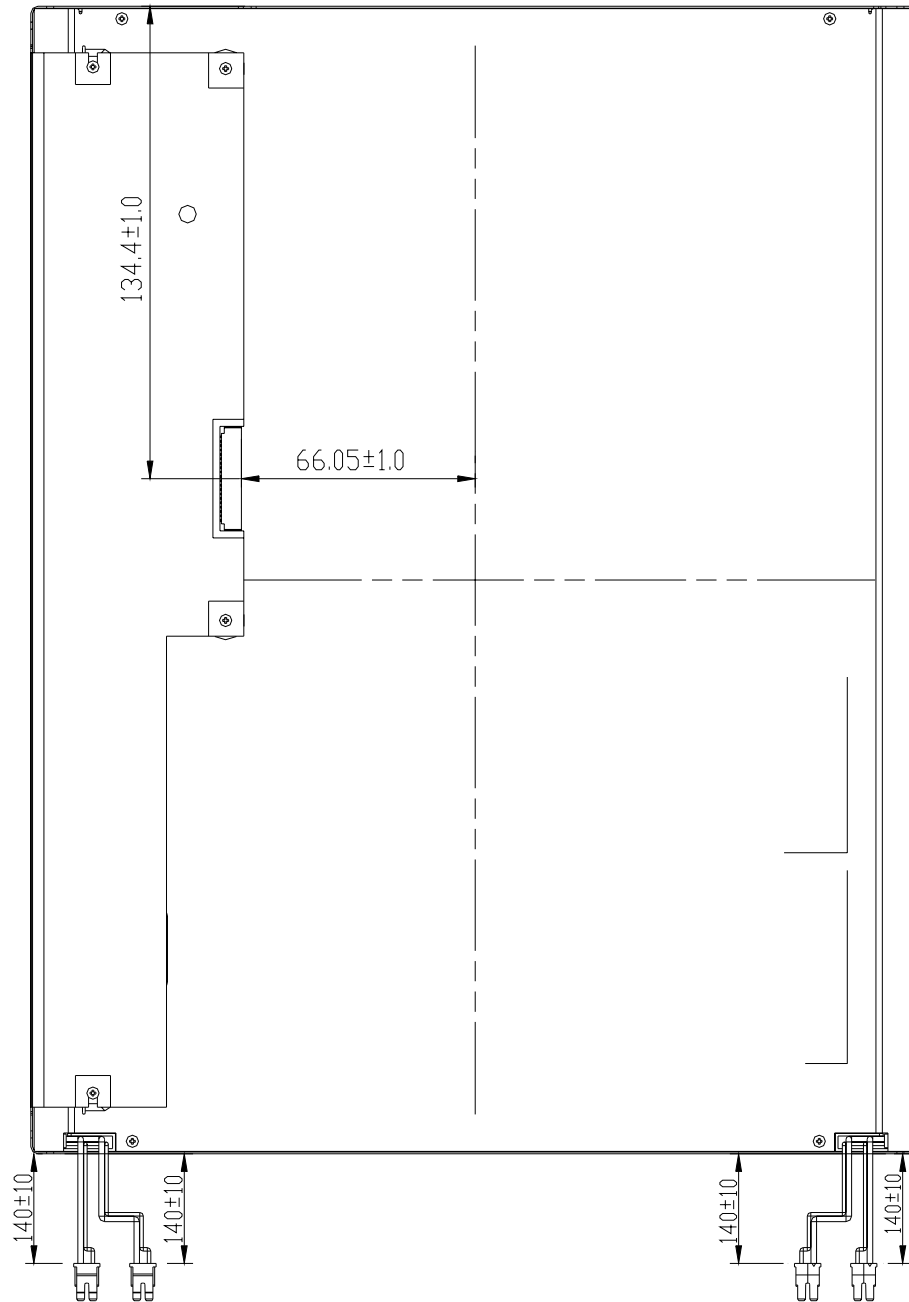

10. OPTICAL CHARACTERISTICS

Ta = 25°C, VCC=3.3V

ITEM		SYMBOL	CONDITION	MIN.	TYP.	MAX.	UNIT	REMARK
Contrast (CEN)		CR	$\theta = \phi = 0^\circ$	450	500	--	--	*1)
Luminance (CEN)		L	$\theta = \phi = 0^\circ$	330	450	--	cd/m ²	*2)
5P Luminance (AVG)		L	$\theta = \phi = 0^\circ$	310	400	--	cd/m ²	*2)
5P Uniformity		ΔL	$\theta = \phi = 0^\circ$	75	80	--	%	*2)
Response Time		Tr	$\theta = \phi = 0^\circ$	--	2	4	ms	*4)
		Tf	$\theta = \phi = 0^\circ$	--	6	10	ms	
View angle	Horizontal	ϕ	$CR \geq 10$	120	140	--	Deg.	*3)
	Vertical	θ		105	125	--	Deg.	
View angle	Horizontal	ϕ	$CR \geq 5$	150	170	--	Deg.	*3)
	Vertical	θ		150	170	--	Deg.	
Color Coordinates	White	X	$\theta = \phi = 0^\circ$	0.252	0.282	0.312	--	--
		Y		0.263	0.293	0.323		
	Red	X		0.613	0.643	0.673		
		Y		0.305	0.335	0.365		
Green	X	0.267	0.297	0.327				
	Y	0.558	0.588	0.618				
Blue	X	0.112	0.142	0.172				
	Y	0.048	0.078	0.108				
Color Temperature		K	--	--	9600	--	K	--
Gamma		r	--	2.0	2.2	2.4	--	*5)

[Note]

These items are measured using BM-5A (TOPCON) under the dark room condition (no ambient light).

Measurement Condition: IL=6.5±0.1mA

Inverter: MPT-M034, Frequency=50kHz.

Definition of these measurement items is as follows:

*1) Definition of Contrast Ratio

CR=ON (White) Luminance/OFF (Black) Luminance

*2) Definition of Luminance and Luminance uniformity

Central luminance: The white luminance is measured at the center position "5" on the screen, see Figure.1 below.

5P Luminance (AVG): The white luminance is measured at measuring points 1 to 5, see Figure 1 below.

5P Uniformity: $\Delta L = (L_{MIN} / L_{MAX}) \times 100\%$ see Figure 1 below.

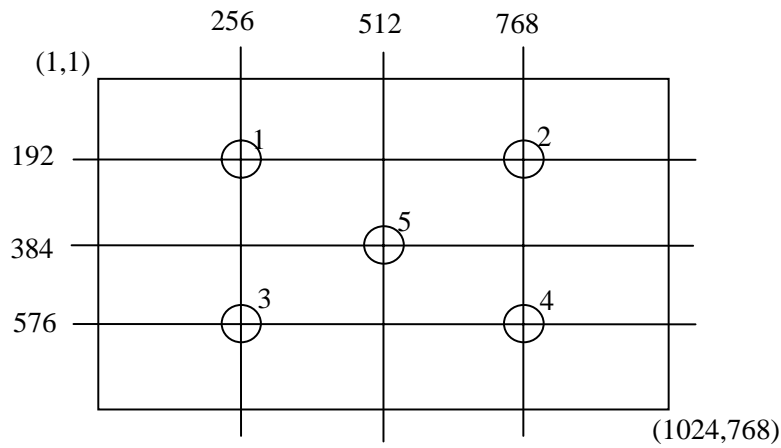
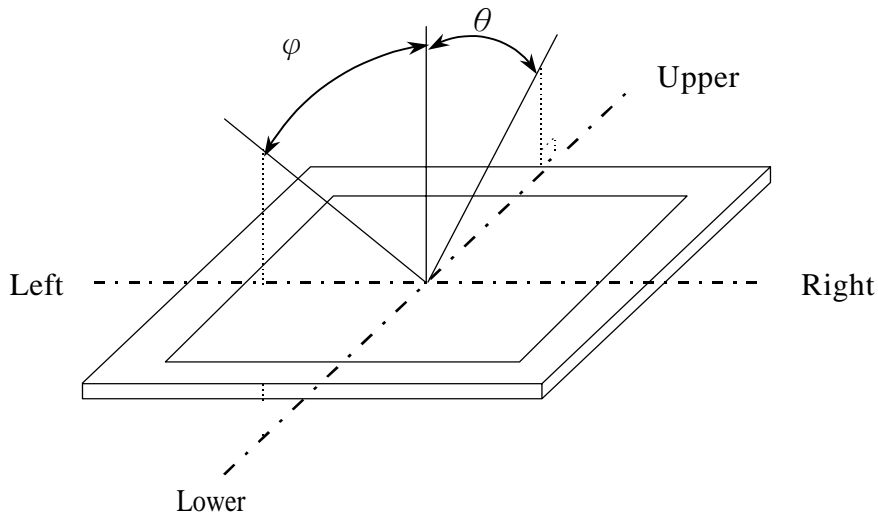

Figure 1. Measurement positions for 5 points

*3) Definition of Viewing Angle(θ, ϕ)



*4) Definition of Response Time

Change the module frame to Black/white pattern and use Westar TDR-100 to measure t_r and t_f under 25°C room temperature.

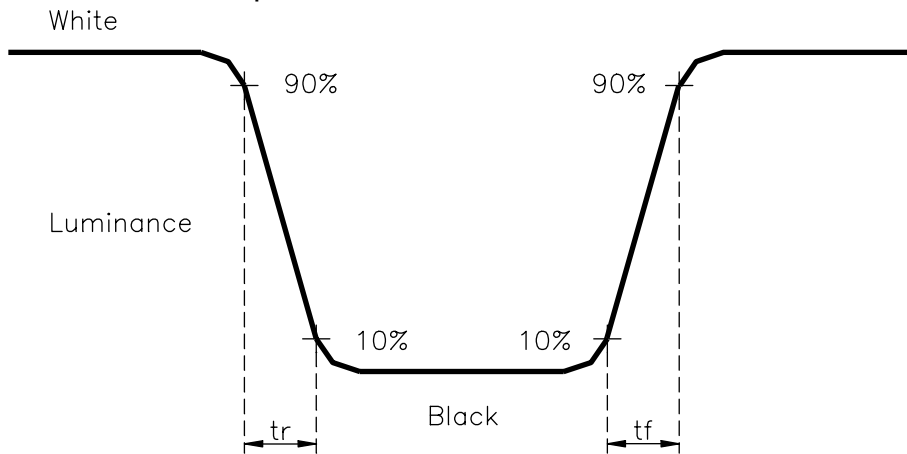

*5) Based on Customer Sample, take the average value as a standard center value and the variation range of Gamma value caused by loop voltage error should be between +/- 0.2.

11. RELIABILITY TEST CONDITIONS

(1) Temperature and Humidity

TEST ITEMS	CONDITIONS
High Temperature High Humidity Operation	50°C; 90%RH; 240hrs (No condensation)
High Temperature High Humidity Storage	60°C; 90%RH; 48hrs (No condensation)
High Temperature Operation	50°C; 240hrs
High Temperature Storage	60°C; 240hrs
Low Temperature Operation	0°C; 240hrs
Low Temperature Storage	-20°C; 240hrs

(2) Shock & Vibration

ITEMS	CONDITIONS
Shock (Non-Operation)	Shock level: 1470m/s ² (150G) Waveform: half sinusoidal wave, 2ms Number of shocks: one shock input in each direction of three mutually perpendicular axes for a total of six shock inputs.
Vibration (Non-Operation)	Vibration level: 9.8m/s ² (1.0G) zero to peak Waveform: sinusoidal Frequency range: 5 to 500 Hz Frequency sweep rate: 0.5 octave/min Duration: one sweep from 5 to 500Hz in each of three mutually perpendicular axis(each x,y,z axis: 1 hour, total 3 hours).

(2)ESD test

TEST ITEM	TEST STATEMENTS
Connector	200 pF, 0 Ω, ±250 V By using contact-mode to discharge each pin one time (every 1sec) and then check the module frame.
Module	1. Test statements:150 pF, 330 Ω, ±15kV Under non-operation testing conditions, by using air-mode to discharge each test point 25 times (discharge time space:1s) continuously and then check the module frame. 2. Test statements:150pF, 330Ω, ±2KV Under operation testing conditions, by using contact mode to discharge the front bezel and using air mode to discharge the points of panel.

(4) Judgment standard

The judgment of the above test should be made as follow:

Pass: Normal display image with no obvious non-uniformity and no line defect.

Partial transformation of the module parts should be ignored.

Fail: No display image, obvious non-uniformity, or line defects.

12. HANDLING PRECAUTIONS FOR TFT-LCD MODULE

Please pay attention to the followings in handling- TFT-LCD products.

12.1 ASSEMBLY PRECAUTION

- (1) Please use the mounting hole on the module side in installing and do not beading or wrenching LCD in assembling. And please do not drop, bend or twist LCD module in handling.
- (2) Please design display housing in accordance with the following guidelines.
 - Housing case must be destined carefully and do not to put stresses on LCD all sides or wrench module. The stresses may cause non-uniformity even if there is no non-uniformity statically.
 - Keep sufficient clearance between LCD module back surface and housing when the LCD module is mounted. Approximately 1.0 mm of the clearance in the design is recommended taking into account the tolerance of LCD module thickness and mounting structure height on the housing.
 - When some parts, such as, FPC cable and ferrite plate, are installed underneath the LCD module, still sufficient clearance is required, such as 0.5mm. This clearance is, especially, to be reconsidered when the additional parts are implemented for EMI countermeasure.
 - Design the inverter location and connector position carefully so as not to put stress on lamp cable.
 - Keep sufficient clearance between LCD module and the other parts, such as inverter and speaker so as not to interface the LCD module. Approximately 1.0mm of the clearance in the design is recommended.
- (3) Please do not push or scratch LCD panel surface with any-thing hard. And do not soil LCD panel surface by touching with bare hands. (Polarizer film and surface of LCD panel are easy to be flawed.)
- (4) Please do not press any parts on the rear side such as source TCP, gate TCP, control circuit board and FPC during handling the LCD module. If pressing rear part could not be avoided, handle the LCD module with care not to damage them.
- (5) Please wipe out LCD panel surface with absorbent cotton or soft clothe in case of it being soiled.
- (6) Please wipe out drops of adhesives like saliva and water on LCD panel surface immediately. They might damage to cause panel surface variation and color change.
- (7) Please do not take a LCD module to pieces and reconstruct it. Resolving and reconstructing modules may cause them not to work well.
- (8) Please do not touch metal frames with bare hands and soiled gloves. A color change of the metal frames can happen during a long preservation of soiled LCD modules.

- (9) Please pay attention to handling lead wire of backlight so that it is not tugged in connecting with inverter.

12.2 OPERATING PRECAUTIONS

- (1) Please be sure to turn off the power supply before connecting and disconnecting signal input cable.
- (2) Please do not change variable resistance settings in LCD module. They are adjusted to the most suitable value. If they are changed, it might happen LCD does not satisfy the characteristics specification.
- (3) Please consider that LCD backlight takes longer time to become stable of radiation characteristics in low temperature than in room temperature.
- (4) A condensation might happen on the surface and inside of LCD module in case of sudden change of ambient temperature.
- (5) Please pay attention to displaying the same pattern for a very long time. Image might stick on LCD. If then, time going on can make LCD work well.
- (6) Please obey the same caution descriptions as ones that need to pay attention to ordinary electronic parts.

12.3 PRECAUTIONS WITH ELECTROSTATICS

- (1) This LCD module use CMOS-IC on circuit board and TFT-LCD panel, and so it is easy to be affected by electrostatics. Please be careful with electrostatics by the way of your body connecting to the ground and so on.
- (2) Please remove protection film very slowly on the surface of LCD module to prevent from electrostatics occurrence.

12.4 STORAGE PRECAUTIONS

- (1) When you store LCD for a long time, it is recommended to keep the temperature between 0°C ~40°C without the exposure of sunlight and keep the humidity less than 90%RH.
- (2) Please do not leave the LCD in the environment of high humidity and high temperature such as 60°C 90%RH.
- (3) Please do not leave the LCD in the environment of low temperature(can not lower than -20°C).

12.5 SAFETY PRECAUTIONS

- (1) When you waste LCD, it is recommended to crush damaged or unnecessary LCD into pieces and wash them off with solvents such as acetone and ethanol, which should later be burned.
- (2) If any liquid leaks out of a damaged-glass cell and comes in contact with the hands, wash off thoroughly with soap and water.

12.6 OTHERS

- (1) A strong incident light into LCD panel might cause display characteristics' changing inferior because of polarizer film, color filter, and other materials becoming inferior. Please do not expose LCD module direct sunlight and strong UV rays.
- (2) Please pay attention on the side of LCD module do not contact with other materials in preserving it alone.
- (3) For the packaging box, please pay attention to the followings:
 - Packaging box and inner case for LCD are designed to protect the LCD from the damage or scratching during transportation. Please do not open except picking LCD up from the box.
 - Please do not pile them up more than 3 boxes. (They are not designed so.) And please do not turn over.
 - Please handle packaging box with care not to give them sudden shock and vibrations. And also please do not throw them up.
 - Packing box and inner case for LCD are made of cardboard. So please pay attention not to get them wet. (Such as keep them away the high humidity or wet place.)