



Chunghwa Picture Tubes, Ltd. Product Specification

To :
Date :

TFT LCD
CLAA102NA0DCW

ACCEPTED BY : (V1.0)
Tentative

APPROVED BY	CHECKED BY	PREPARED BY

Prepared by :
Product Planning Management Division
Small & Medium TFT Product Business Unit
CHUNGHWA PICTURE TUBES, LTD.

1127 Hopin Rd., Padeh, Taoyuan, Taiwan 334, R.O.C.
TEL: +886-3-3675151 FAX: +886-3-377--3858

Doc.No:	SPEC_CLAA102NA0DCW_V1.0_CPT_100322	Issue Date:	2010/03/22
---------	------------------------------------	-------------	------------

REVISION STATUS

Revision Notice	Description	Page	Rev. Date
Ver. 0.0	First revision (Tentative)		2010/01/28
Ver. 1.0	MDL Depth / Power Consumption / Color Coordinate	P.4 P.15	2010/03/22

CONTENTS

1. OVERVIEW	4
2. ABSOLUTE MAXIMUM RATINGS	5
3. ELECTRICAL CHARACTERISTICS	6
3.1 TFT LCD Power Voltage.....	6
3.2 TFT-LCD Current Consumption.....	7
3.3 Power 、 Signal sequence	7
4. INTERFACE CONNECTION	8
5. INPUT SIGNAL	9
5.1 Timing Specification.....	9
5.2 Timing sequence (Timing chart)	9
5.3 Color data assignment.....	11
6. BLOCK DIAGRAM	12
7. MECHANICAL DIMENSION	13
7.1 Front Side	13
7.2 Rear Side.....	14
8. OPTICAL CHARACTERISTICS	15
9. RELIABILITY TEST	17
9.1. Temperature and humidity.....	17
9.2. Shock and Vibration.....	17
9.3. ESD Test	17
9.4 Judgment Standard	17

1. OVERVIEW

CLAA102NA0DCW is 25.8 cm(10.2") color TFT-LCD (Thin Film Transistor Liquid Crystal Display) module composed of LCD panel, driver ICs, control circuit, and backlight.

The 10.2" screen produces a high resolution image that is composed of 1024x600 pixel elements in a stripe arrangement. Display 262K colors by 6 Bit R.G.B signal input. Use 3.3 voltage to drive the power of LCD system, and 12.0 Voltage to drive the LED back light.

General specification are summarized in the following table:

ITEM	SPECIFICATION			
Panel Size	10.2 inch(panel diagonal)			
Display Area (mm)	222.72(H) x 130.5(V) (10.2-inch diagonal)			
Number of Pixels	1024(H) x 3(RGB) x 600(V)			
Pixel Pitch (mm)	0.2175 (H) x 0.2175 (V)			
Color Pixel Arrangement	RGB vertical stripe			
Display Mode	Normally white			
Number of colors	262,144			
Brightness(cd/m ²)	400(typ.)			
Response Time (Tr+Tf)	20 ms			
Outline Dimension(mm)		Min.	Typ.	Max.
	Horizontal (H)	234.7	235	235.3
	Vertical (V)	145.5	145.8	146.1
	Depth (D)	5.0	5.3	5.6
Viewin Angle(BL on,CR \geq 10)	140 degree(H) , 120 degree(V)			
Power consumption (W)	4.8			
BL unit	LED			
Electrical Interface(data)	LVDS			
Viewing Direction	6 o'clock			
Weight(g)	250			
Surface Treatment	Anti-Glare , Hardness:3H			

2. ABSOLUTE MAXIMUM RATINGS

The following are maximum values which, if exceeded, may cause faulty operation or damage to the unit.

ITEM	SYMBOL	MIN.	MAX.	UNIT	NOTE
Power Supply Voltage	V _{cc}	-0.3	4.0	V	
LED Supply Voltage	V _{LED}	-0.3	13.0	V	
Static Electricity	VESD _c	-200	200	V	【Note2】
	VESD _m	-15K	15K	V	
ICC Rush Current	IRUSH	-	1	A	【Note 3】
Operation Temperature	T _{op}	-20	70	°C	【Note 1】
Storage Temperature	T _{stg}	-30	80	°C	【Note 1】

【Note】

【Note1】 If users use the product out off the environment operation range (temperature and humidity) ,it will concern for visual quality.

【Note2】 Test Condition: IEC 61000-4-2 ,
 VESD_c : Contact discharge to input connector
 VESD_m : Discontact discharge to module

【Note3】 The input pulse-current measurement system as below :

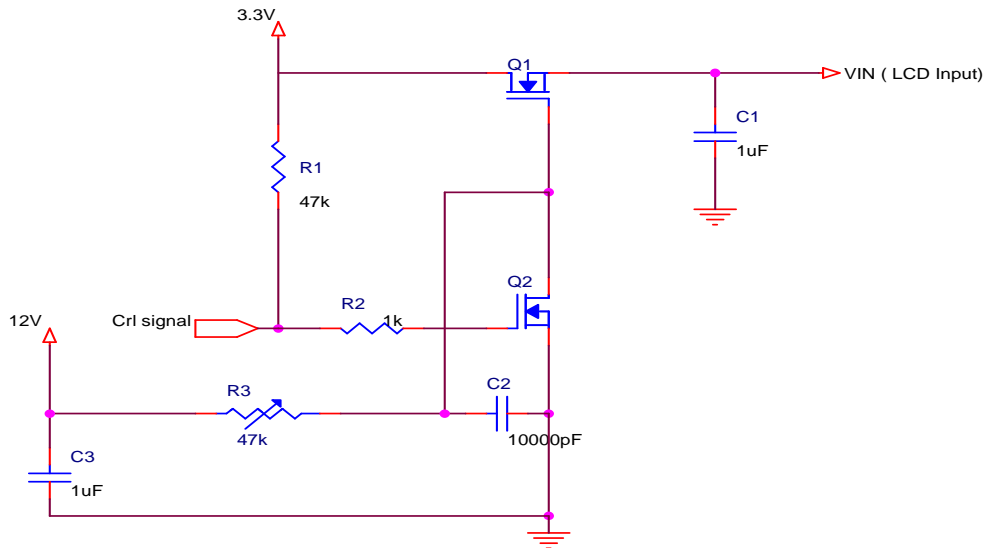

Control signal:High(+3.3V)→Low(GND)

Supply Voltage of rising time should be from R3 and C2 tune to 550 us.

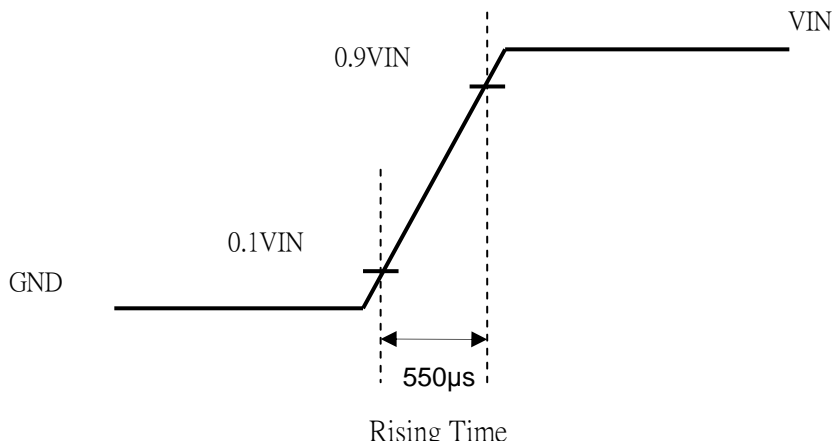

3. ELECTRICAL CHARACTERISTICS

3.1 TFT LCD Power Voltage

 $T_a=25^{\circ}\text{C}$

ITEM	SYMBOL	MIN.	TYP.	MAX.	UNIT	NOTE	
Power Supply Voltage For LCD	V_{CC}	3.0	3.3	3.6	V	【Note 1】	
Power Supply Voltage For LED	V_{LED}	11.5	12	12.5	V		
Logic Input Voltage (LVDS:IN+,IN-)	Input Voltage	V_{IN}	0	-	V_{CC}	V	【Note 2】
	Common Mode Voltage	V_{CM}	1.08	1.2	1.32	V	【Note 2】
	Differential Input Voltage	$ V_{ID} $	250	350	450	mV	【Note 2】
	Threshold Voltage(high)	V_{TH}	-	-	100	mV	【Note 2】
	Threshold Voltage(low)	V_{TL}	-100	-	-	mV	【Note 2】
ADJ Input Voltage	Input Voltage(high)	V_{IH}	3.0		3.3	V	
	Input Voltage(low)	V_{IL}	GND		0.3	V	

Remarks :

【Note1】 V_{CC} -dip condition:

- 1) When $2.7\text{V} \leq V_{CC} < 3.0\text{V}$, $t_d \leq 10\text{ms}$.
- 2) $V_{CC} > 3.0\text{V}$, V_{CC} -dip condition should be same as V_{CC} -turn-on condition.

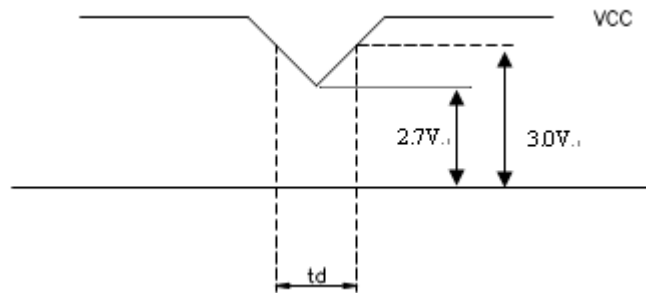

【Note 2】 LVDS signal

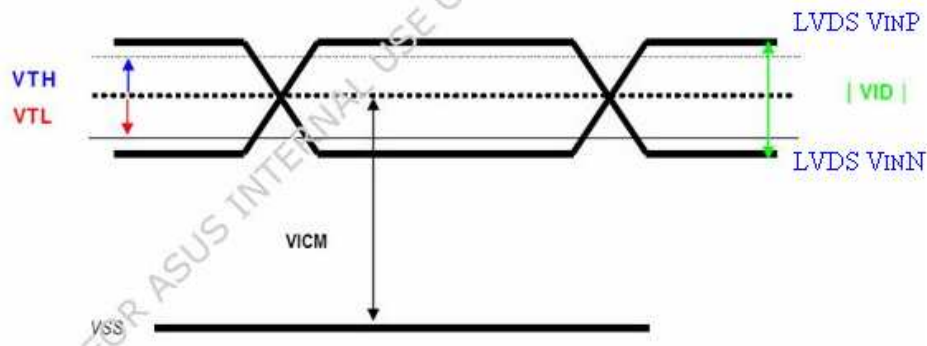

3.2 TFT-LCD Current Consumption

ITEM	SYMBOL	MIN.	TYP.	MAX.	UNIT	NOTE
LCD Power Current	I_{CC}	--	250	350	mA	【Note1】
LED Power Current	I_{LED}	--	300	450	mA	【Note2】

【Note1】 (Frame rate = 60 Hz)

Typical: Under 64 gray pattern @ $V_{CC} = 3.3 V$

Maximum: Under black pattern @ $V_{CC} = 3.0 V$



(a) 64 Gray Pattern

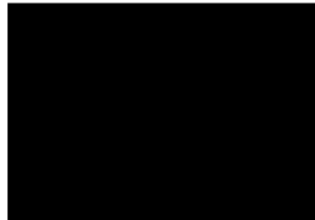

(b) Black Pattern

【Note2】 Typical: When V_{LED} is 12.0V

Maximum: When V_{LED} is 11.5V

3.3 Power · Signal sequence

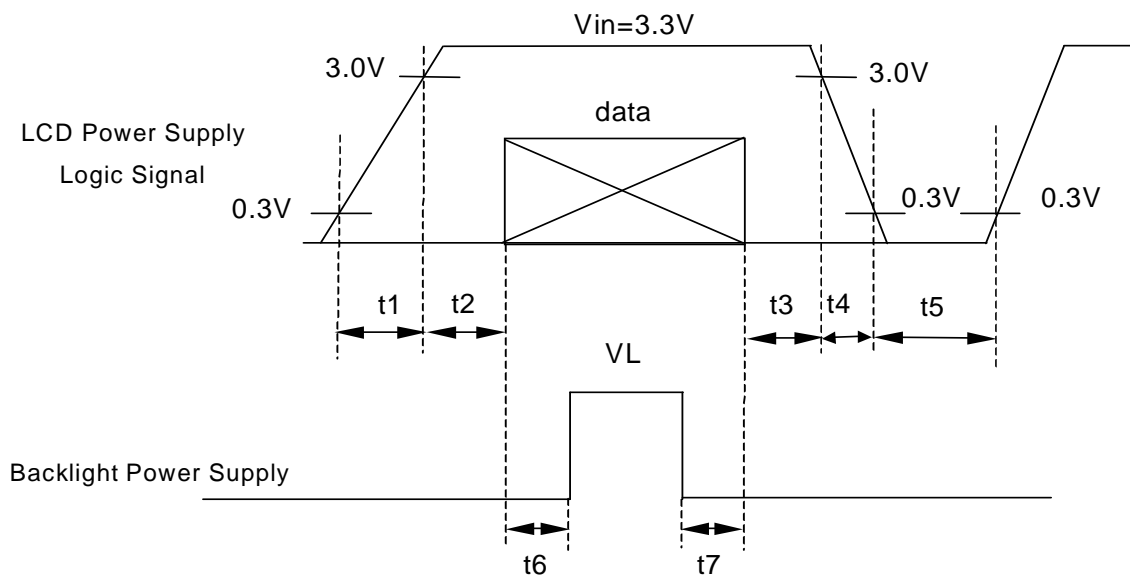

Data: RGB DATA, DCLK, DENA

- $0.5 < t1 \leq 10ms$
- $0 < t2 \leq 50ms$
- $0 < t3 \leq 50ms$
- $0 < t4 \leq 10ms$
- $200ms \leq t5$
- $200ms \leq t6$
- $200ms \leq t7$

4. INTERFACE CONNECTION

CN1 : Connector type : 093F30-B0B01A or compatible.

Pin No.	SYMBOL	FUNCTION
1	GND	Ground
2	V _{CC}	+3.3V Power
3	V _{CC}	+3.3V Power
4	V_EDID	3.3V Power for NB
5	ADJ	Adjust for LED brightness
6	NC	NC
7	NC	NC
8	RXIN0-	LVDS Signal(-)—channel 0
9	RXIN0+	LVDS Signal(+)—channel 0
10	GND	Ground
11	RXIN1-	LVDS Signal(-)—channel 1
12	RXIN1+	LVDS Signal(+)—channel 1
13	GND	Ground
14	RXIN2-	LVDS Signal(-)—channel 2
15	RXIN2+	LVDS Signal(+)—channel 2
16	GND	Ground
17	RXCLKIN-	LVDS Clock Signal(-)
18	RXCLKIN+	LVDS Clock Signal(+)
19	GND	Ground
20	NC	NC
21	NC	NC
22	GND	Ground
23	GND	Ground
24	V _{LED}	Power Supply for LED(V _{LED} =12.0±0.5)
25	V _{LED}	Power Supply for LED(V _{LED} =12.0±0.5)
26	V _{LED}	Power Supply for LED(V _{LED} =12.0±0.5)
27	NC	NC
28	NC	NC
29	NC	NC
30	NC	NC

【Note】

1) ADJ adjust brightness to control Pin , Pulse duty the bigger the brighter.

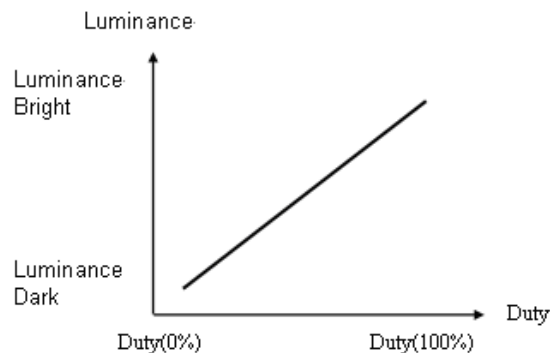

2) ADJ signal=0~3.3V , operation frequency : 25KHZ±5KHz, ADJ pin should not connect to GND, it should pull-high if not adjust brightness.

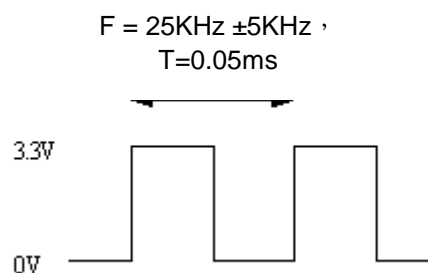

3) GND Pin must ground contact , can not be floating.

5. INPUT SIGNAL

5.1 Timing Specification

ITEM		SYMBOL	MIN.	TYP.	MAX.	UNIT	
LVDS input signal sequence	CLK Frequency		fCLKin	39.05	45	50	MHz
	CLK Period		tCLKin	25.61	22.22	20.00	ns
LCD input timing	Horizontal	Horizontal Period	t _H	1160	1200	1240	tCLK
		Horizontal Valid	t _{HA}	1024	1024	1024	tCLK
		Horizontal Blank	t _{HB}	136	176	216	tCLK
	Vertical	Frame	fV	55	60	65	Hz
		Vertical Period	t _V	612	625	638	t _H
		Vertical Valid	t _{VA}	600	600	600	t _H
	Vertical Blank	t _{VB}	12	25	38	t _H	

5.2 Timing sequence (Timing chart)

5.2.1 Horizontal Timing Sequence

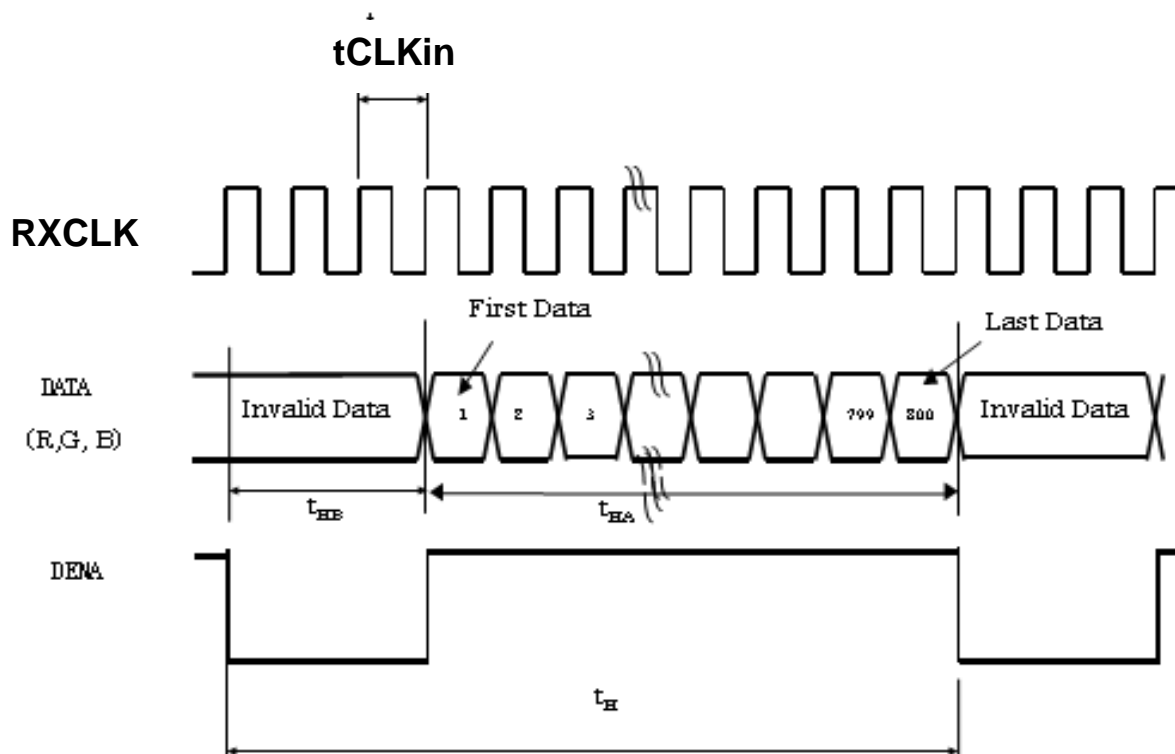

5.2.2 Vertical Timing Sequence

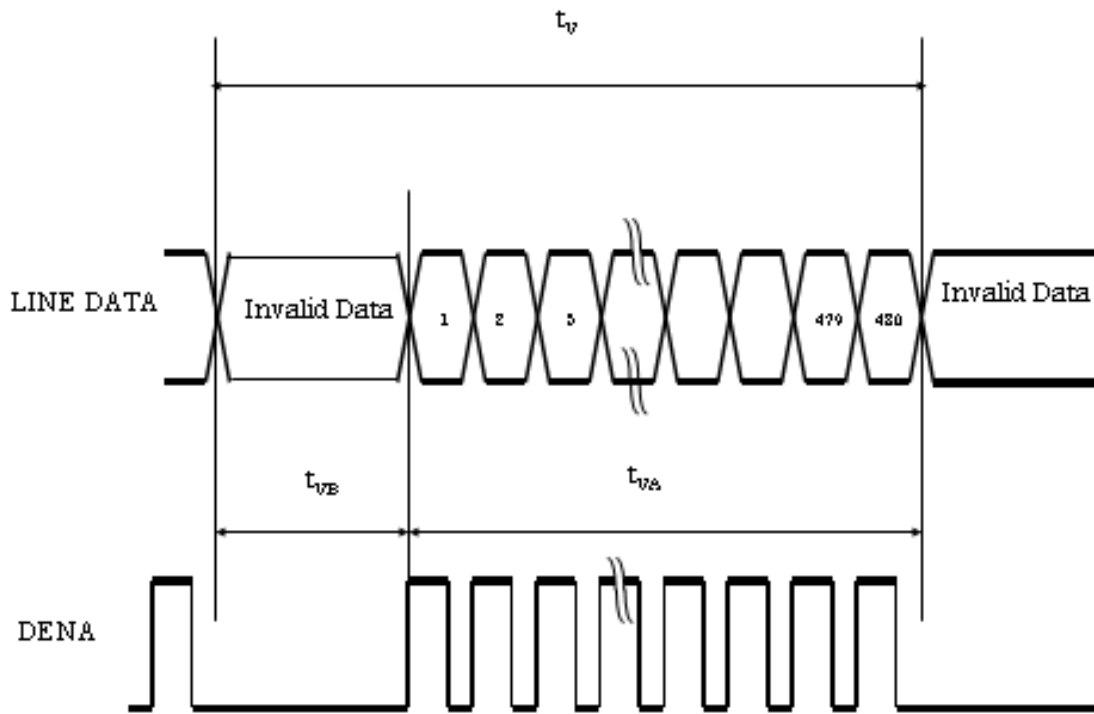

5.2.3 LVDS Input Data mapping

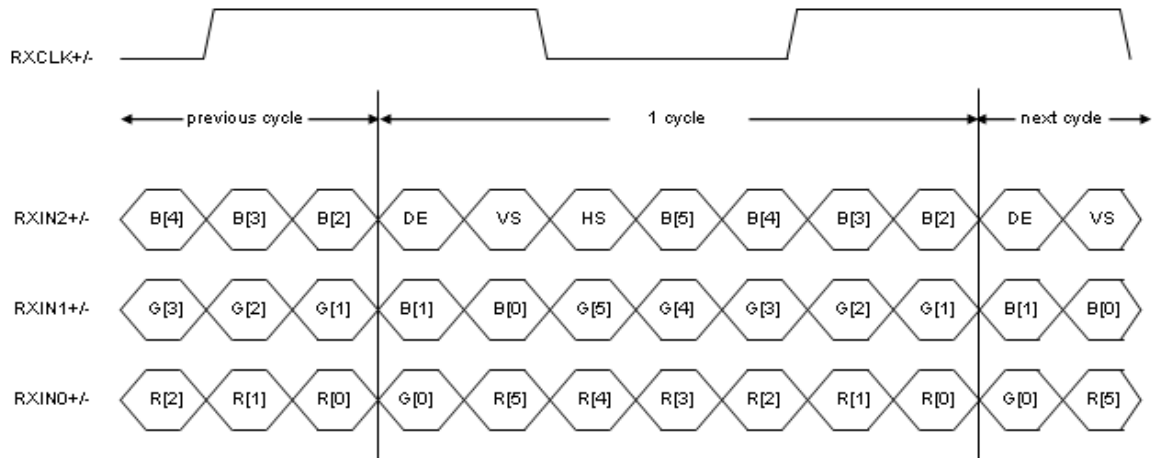

5.3 Color data assignment

COLOR	INPUT	R DATA						G DATA						B DATA					
	DATA	R5	R4	R3	R2	R1	R0	G5	G4	G3	G2	G1	G0	B5	B4	B3	B2	B1	B0
		MSB					LSB	MSB					LSB	MSB					LSB
BASIC COLOR	BLACK	0	0	0	0	0	0	0	0	0	0	0	0	0	0	0	0	0	0
	RED(63)	1	1	1	1	1	1	0	0	0	0	0	0	0	0	0	0	0	0
	GREEN(63)	0	0	0	0	0	0	1	1	1	1	1	1	0	0	0	0	0	0
	BLUE(63)	0	0	0	0	0	0	0	0	0	0	0	0	1	1	1	1	1	1
	CYAN	0	0	0	0	0	0	1	1	1	1	1	1	1	1	1	1	1	1
	MAGENTA	1	1	1	1	1	1	0	0	0	0	0	0	1	1	1	1	1	1
	YELLOW	1	1	1	1	1	1	1	1	1	1	1	1	0	0	0	0	0	0
	WHITE	1	1	1	1	1	1	1	1	1	1	1	1	1	1	1	1	1	1
RED	RED(0)	0	0	0	0	0	0	0	0	0	0	0	0	0	0	0	0	0	0
	RED(1)	0	0	0	0	0	1	0	0	0	0	0	0	0	0	0	0	0	0
	RED(2)	0	0	0	0	1	0	0	0	0	0	0	0	0	0	0	0	0	0
	RED(62)	1	1	1	1	1	0	0	0	0	0	0	0	0	0	0	0	0	0
	RED(63)	1	1	1	1	1	1	0	0	0	0	0	0	0	0	0	0	0	0
GREEN	GREEN(0)	0	0	0	0	0	0	0	0	0	0	0	0	0	0	0	0	0	0
	GREEN(1)	0	0	0	0	0	0	0	0	0	0	0	1	0	0	0	0	0	0
	GREEN(2)	0	0	0	0	0	0	0	0	0	0	1	0	0	0	0	0	0	0
	GREEN(62)	0	0	0	0	0	0	1	1	1	1	1	0	0	0	0	0	0	0
	GREEN(63)	0	0	0	0	0	0	1	1	1	1	1	1	0	0	0	0	0	0
BLUE	BLUE(0)	0	0	0	0	0	0	0	0	0	0	0	0	0	0	0	0	0	0
	BLUE(1)	0	0	0	0	0	0	0	0	0	0	0	0	0	0	0	0	0	1
	BLUE(2)	0	0	0	0	0	0	0	0	0	0	0	0	0	0	0	0	1	0
	BLUE(62)	0	0	0	0	0	0	0	0	0	0	0	0	1	1	1	1	1	0
	BLUE(63)	0	0	0	0	0	0	0	0	0	0	0	0	1	1	1	1	1	1

【Note1】 Definition of Gray Scale

color(n) : n is series of Gray Scale. The more n value is, the bright Gray Scale.

【Note2】 Data:1-High,0-Low

6. BLOCK DIAGRAM

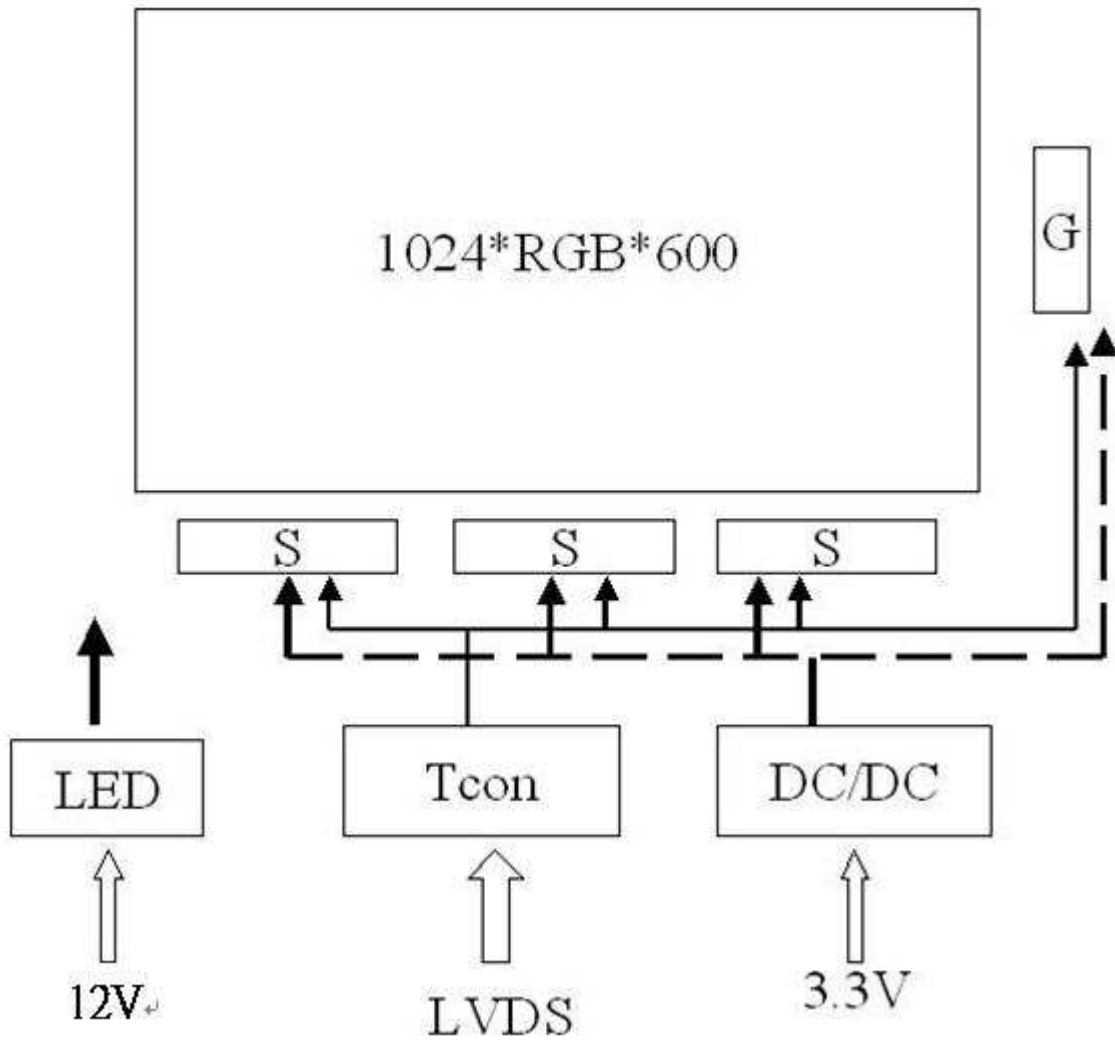

7. MECHANICAL DIMENSION

7.1 Front Side

[Unit : mm]

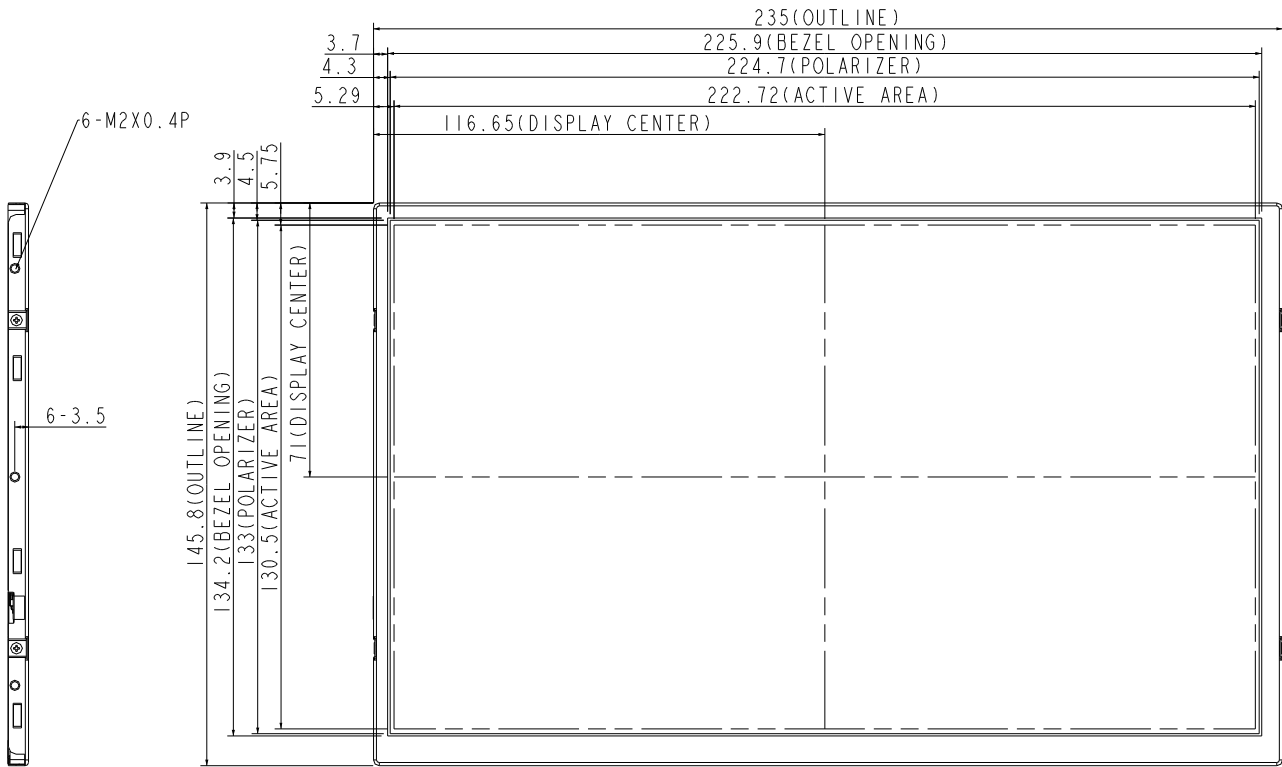

[Note] : Tolerance is $\pm 0.3\text{mm}$ unless noted

7.2 Rear Side

[Unit : mm]

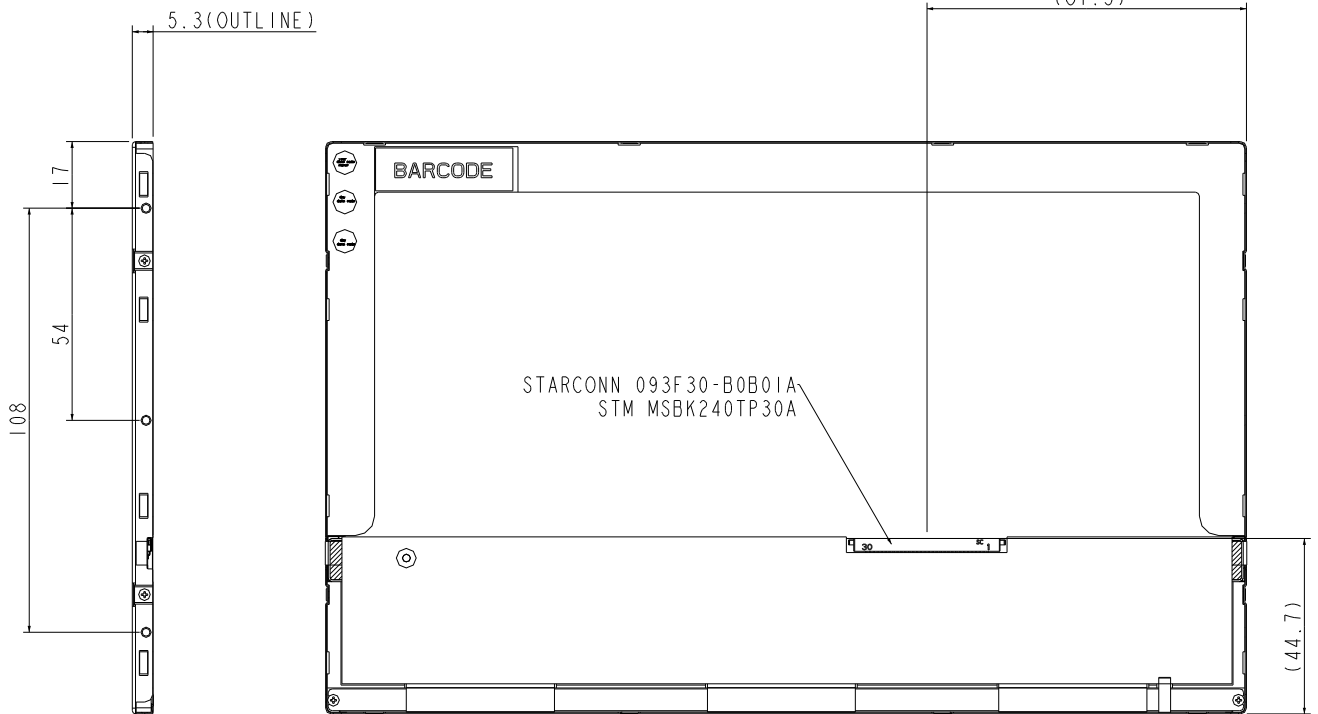

NOTES:

1. GENERAL TOLERANCE: $\pm 0.3\text{mm}$.
2. ALLOW ED DEPTH OF USERHOLE SCREW INSERTION IS 1.5mm MAX.
3. USERHOLE SCREW OF TORQUE=2.5 kgf/cm MAX.

[Note] : Tolerance is $\pm 0.3\text{mm}$ unless noted

8. OPTICAL CHARACTERISTICS

 $T_a = 25^{\circ}\text{C}, V_{CC} = 3.3\text{V}$

ITEM	SYMBOL	CONDITION	MIN.	TYP.	MAX.	UNIT	NOTE	
Constrast Ratio	CR	Point-5	320	400	--	--	*1)*2)*3)	
Luminance*)	Lw	Point-5	360	400	--	cd/m ²	*1)*3)	
Luminance Uniformity	ΔL		70	80		%	*1)*3)	
Response Time (White - Black)	Tr+ Tf	Point-5	--	20	30	ms	*1)*3)*5)	
Viewing Angle	Horizontal	ψ	CR \geq 10 Point-5	110	140	--	$^{\circ}$	*1)*2)*4)
	Vertical	θ		100	120	--	$^{\circ}$	*1)*2)*4)
Color Coordinate	White	Wx Wy	$\theta = \phi = 0^{\circ}$ Point-5	0.273 0.289	0.313 0.329	0.353 0.369	--	*1)*3)
	Red	Rx Ry		0.528 0.296	0.568 0.336	0.608 0.376		
	Green	Gx Gy		0.306 0.534	0.346 0.574	0.386 0.614		
	Blue	Bx By		0.115 0.068	0.155 0.108	0.195 0.148		

NOTE :

*1) Measure condition : $25^{\circ}\text{C} \pm 2^{\circ}\text{C}$, $60 \pm 10\% \text{RH}$, under 10 Lux in the dark room. BM-5A (TOPCON) , viewing angle 2° , $V_{CC} = 3.3\text{V}$, $V_{LED} = 12\text{V}$.

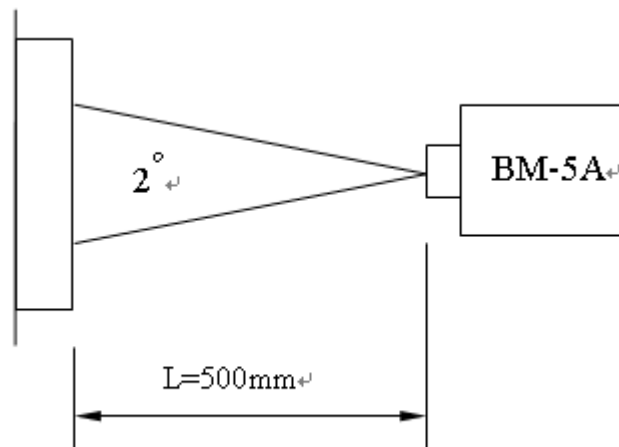

*2) Definition of contrast ratio :

Contrast Ratio (CR) = (White) Luminance of ON \div (Black) Luminance of OFF

- 3) Definition of luminance : Measure white luminance on the point 5 as figure8-1
 Definition of Luminance Uniformity: Measure white luminance on the point1~9 as figure8-1
 $\Delta L = [L(MIN)/L(MAX)] \times 100$

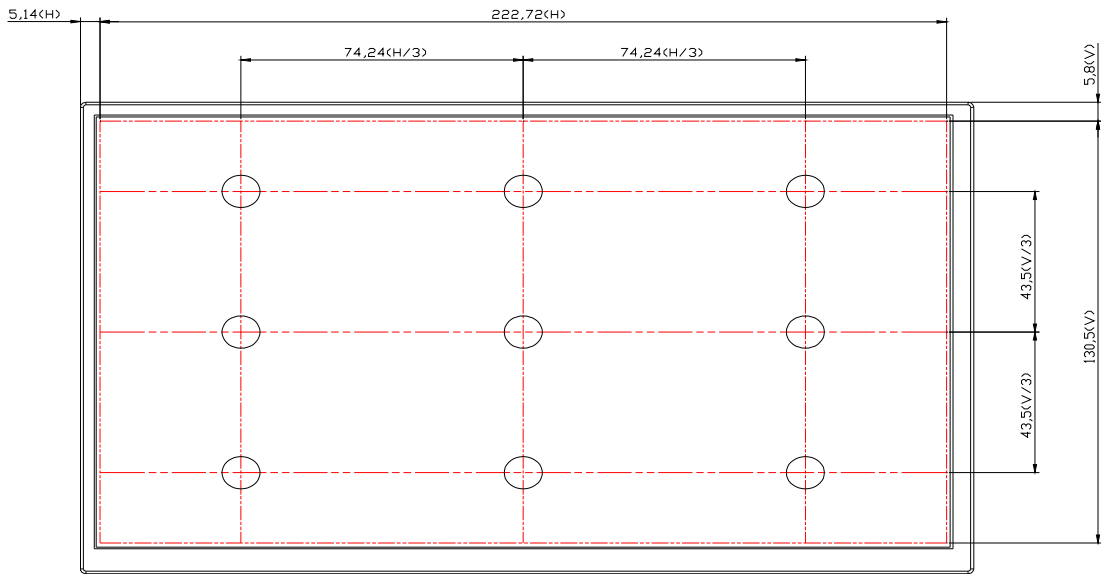

Fig8-1 Measuring point

- *4) Definition of Viewing Angle(θ, ψ), refer to Fig8-2 as below :
 These items are measured by EZ-CONTRAST (ELDIM) in the dark room. (no ambient light).

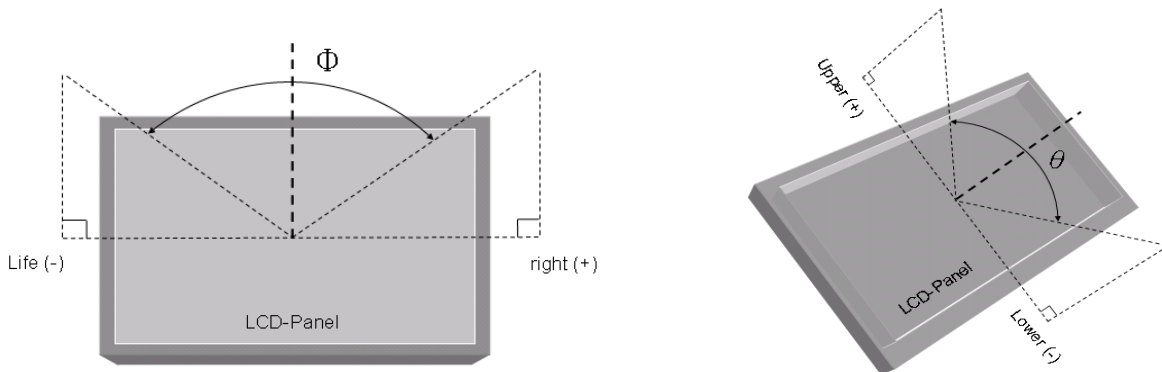

Fig8-2 Definition of Viewing Angle

- *5) Definition of Response Time.(White-Black)

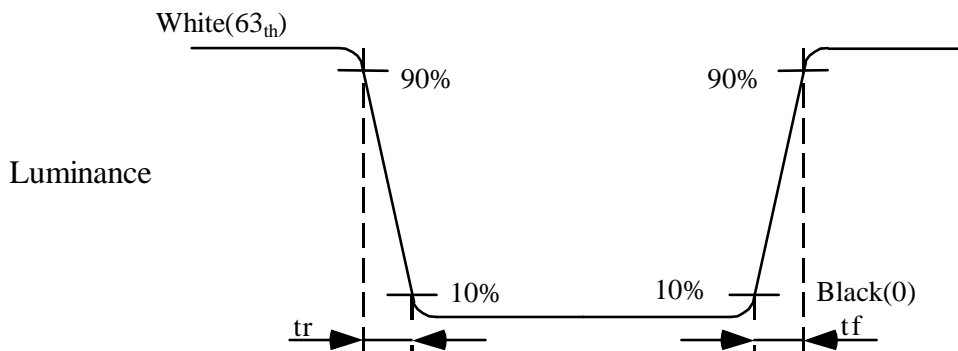

Fig8-3 Definition of Response Time(White-Black)

9. RELIABILITY TEST

9.1. Temperature and humidity

TEST ITEMS	CONDITIONS	NOTE
High Temperature Operation	70°C , 240Hrs	
High Temperature Storage	80°C , 240Hrs	
High Temperature High Humidity Operation	60°C , 90%RH , 240Hrs	No condensation
Low Temperature Operation	-20°C , 240Hrs	
Low Temperature Storage	-30°C , 240Hrs	
Thermal Shock	-30°C (0.5Hr) ~ 80°C(0.5Hr) 200 cycles	

9.2. Shock and Vibration

TEST ITEMS	CONDITIONS
Shock (Non-operation)	<ul style="list-style-type: none"> ● Shock level:980m/s²(equal to 100G) ● Waveform:half sinusoidal wave,6ms. ● Number of shocks:one shock input in each direction of three mutually perpendicular axes for a total of three shock inputs.
Vibration (Non-operation)	<ul style="list-style-type: none"> ● Frequency range:8~33.3Hz ● Stroke:1.3mm ● Vibration:sinusoidal wave,perpendicularaxis(both x, z axis:2Hrs, y axis 4Hrs). ● Sweep:2.9G,33.3Hz-400Hz ● Cycle:15min

9.3. ESD Test

ITEM	CONDITION	NOTE
ESD	150pF , 330Ω , ±8KV&±15KV air & contact test	*1)
	200pF , 0Ω , ±250V contact test	*2)

NOTE:

*1) LCD glass and metal bezel

*2) IF connector pins

9.4 Judgment Standard

The Judgment of the above test should be made as follow:

Pass:Normal display image with no obvious non-uniformity and no line defect.Partial transformation of the module parts should be ignored.

Fail:No display image,obvious non-uniform,or line defect.