



Chunghwa Picture Tubes, Ltd.

Product Specification

To :
Date : 2009/04/14

TFT LCD
CLAA102NA0ACG

ACCEPTED BY :

APPROVED BY	CHECKED BY	PREPARED BY
Ronald Huang	Roger Liu	Carol Shen

Prepared by :
Product Planning Management Division
CHUNGHWA PICTURE TUBES, LTD.

1127 Hopin Rd., Padeh, Taoyuan, Taiwan 334, R.O.C.
TEL: +886-3-3675151 FAX: +886-3-377-3003

Doc.No:	CLAA102NA0ACG-V1-20090414	Issue Date:	20090414
---------	---------------------------	-------------	----------

CONTENTS

1. OVERVIEW.....	4
2. ABSOLUTE MAXIMUM RATINGS	5
3. ELECTRICAL CHARACTERISTICS.....	6
4. INTERFACE CONNECTION.....	8
5. INPUT SIGNAL	9
6. BLOCK DIAGRAM.....	12
7. MECHANICAL DIMENSION	13
8. OPTICAL CHARACTERISTICS.....	14
9. RELIABILITY TEST	16
10. IIS.....	167

1. OVERVIEW

CLAA102NA0ACG is 25.8cm(10.2") color TFT-LCD (Thin Film Transistor Liquid Crystal Display) module composed of LCD panel, driver ICs, control circuit and LED backlight. By applying 1024×600 images are displayed on the 10.2" diagonal screen. Display 262K colors by 6 Bit R.G.B signal input. Use 3.3 voltage to drive the power of LCD system. Use 5.0 voltage to drive the power of LED backlight.

General specification are summarized in the following table:

ITEM	SPECIFICATION
Display Area (mm)	222.72(H) x 130.5(V) (10.2-inch diagonal)
Number of Pixels	1024(H) × 3(RGB) × 600(V)
Pixel Pitch (mm)	0.2175 (H) × 0.2175 (V)
Color Pixel Arrangement	RGB vertical stripe
Display Mode	Normally white, TN
Number of Colors	262,144
Optimum Viewing Angle	6 o'clock
Brightness (cd/m ²)	220nit(typ)
Response Time (Tr+Tf)	20ms (typ)
Viewing Angle(BL on, CR ≥ 10)	140 degree (Horizontal.)
	120 degree (Vertical)
Power Consumption	3.6(w) (Typ)
Electrical Interface(data)	LVDS
Module Size (mm)	235.2(W) × 145.9(H) × 5.9(D)
Module Weight (g)	257(Typ)
Backlight Unit	LED
Surface Treatment	Glare

2. ABSOLUTE MAXIMUM RATINGS

ITEM	SYMBOL	MIN	MAX	UNIT	NOTE
Power Supply Voltage	V _{cc}	-0.3	4.0	V	
LED Supply Voltage	V _{LED}	-0.3	6.0	V	
Signal Input Voltage	RxIN0+ ~ RxIN2+ RxIN0- ~ RxIN2- Rx CLK IN +/-	-0.3	V _{cc} + 0.3	V	
Static Electricity	VESD _c	-200	+200	V	【Note2】
	VESD _m	-15K	+15K	V	
I _{CC} Rush Current	IRUSH	-	1	A	【Note3】
Operation temperature	T _{op}	-30	70	°C	【Note1】
Storage temperature	T _{stg}	-40	80	°C	【Note1】

【Note】

【Note1】 If users use the product out off the environment operation range (temperature and humidity) ,it will concern for visual quality.

【Note2】 Test Condition: IEC 61000-4-2 ,

VESD_c : Contact discharge to input connector

VESD_m : Discontact discharge to module

【Note3】 The input pulse-current measurement system as below :

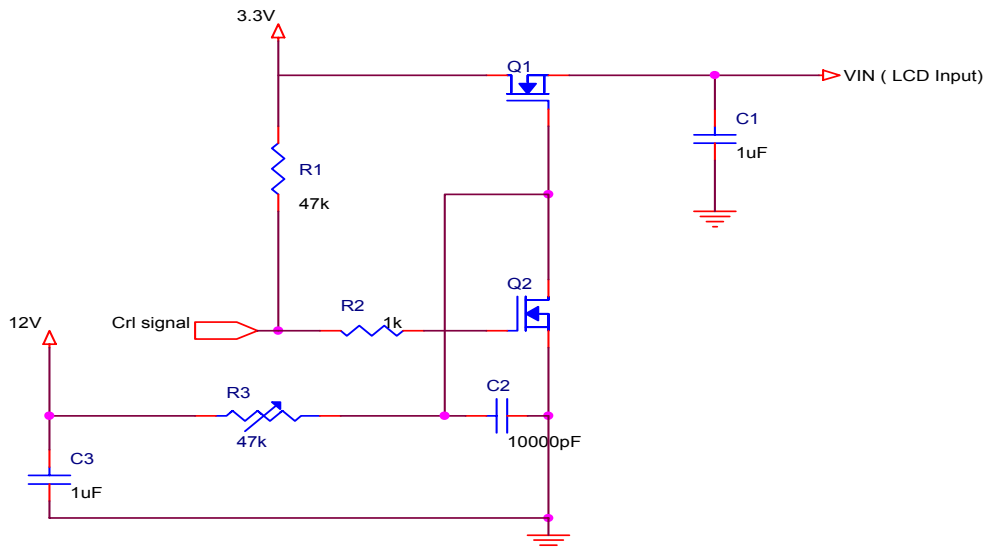

Control signal:High(+3.3V)→Low(GND)

Supply Voltage of rising time should be from R3 and C2 tune to 550 us.

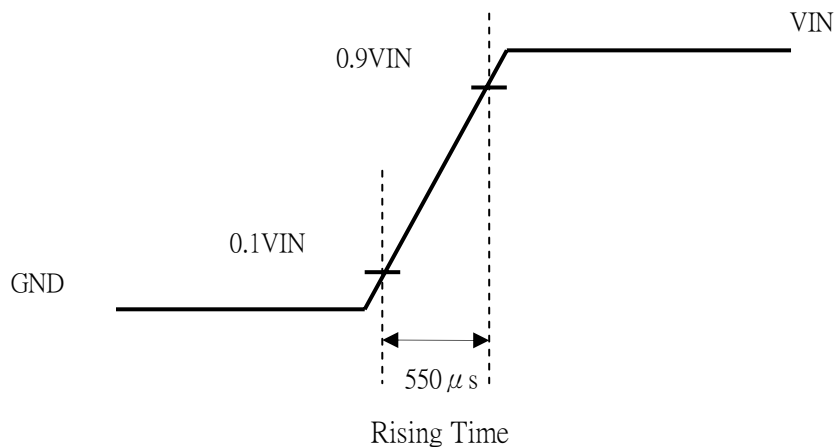

3. ELECTRICAL CHARACTERISTICS

3.1 TFT LCD Power Voltage

Ta=25°C

ITEM	SYMBOL	MIN	TYP	MAX	UNIT	NOTE	
Power Supply Voltage For LCD	V_{CC}	3.0	3.3	3.6	V		
Power Supply Voltage For LED	V_{LED}	4.5	5	5.5	V		
Logic Input Voltage (LVDS:IN+,IN-)	Input Voltage	V_{IN}	0	-	V_{CC}	V	【Note 1】
	Common Mode Voltage	V_{CM}	1.08	1.2	1.32	V	【Note 1】
	Differential Input Voltage	$ VID $	250	350	450	mV	【Note 1】
	Threshold Voltage(high)	V_{TH}	-	-	100	mV	【Note 1】
	Threshold Voltage(low)	V_{TL}	-100	-	-	mV	【Note 1】
ADJ Input Voltage	Input Voltage(high)	V_{IH}	3.0	-	3.3	V	
	Input Voltage(low)	V_{IL}	GND	-	0.3	V	

【Note】

【Note1】 LVDS signal

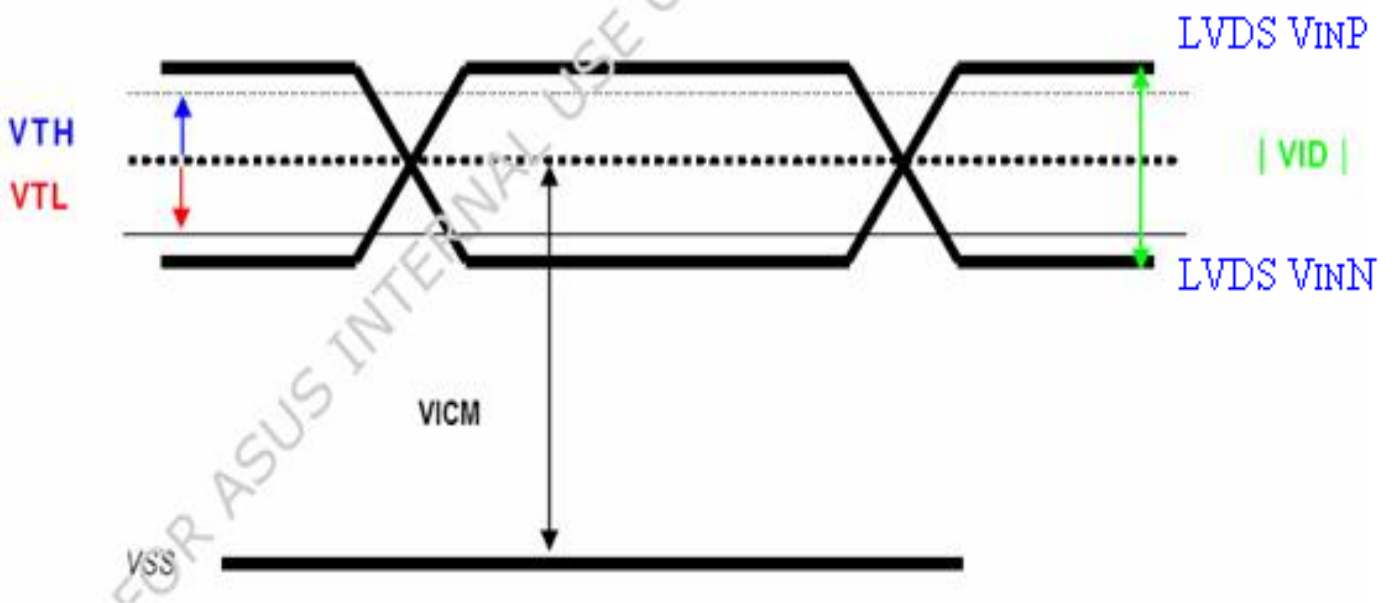

3.2 TFT-LCD Current Consumption

ITEM	SYMBOL	MIN	TYP	MAX.	UNIT	NOTE
LCD Power Current	I_{CC}	--	250	350	mA	【Note1】
LED Power Current	I_{LED}	--	500	600	mA	【Note2】

【Note1】 Typical: Under 64 gray pattern @ $V_{CC} = 3.3\text{ V}$
 Maximum: Under black pattern @ $V_{CC} = 3.0\text{ V}$

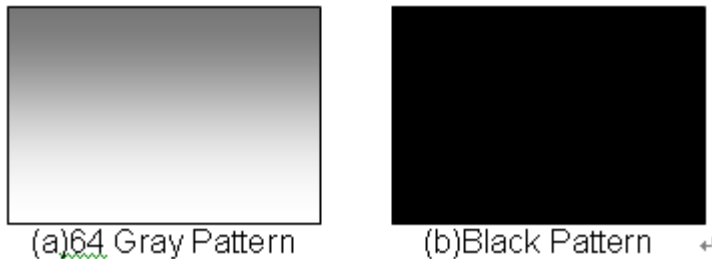

【Note2】 Typical: When V_{LED} is 5V
 Maximum: When V_{LED} is 4.5V

3.3 Power · Signal sequence

- $0.5 < t_1 \leq 10\text{ms}$
- $0 < t_2 \leq 50\text{ms}$
- $0 < t_3 \leq 50\text{ms}$
- $0 < t_4 \leq 10\text{ms}$
- $200\text{ms} \leq t_5$
- $200\text{ms} \leq t_6$
- $200\text{ms} \leq t_7$

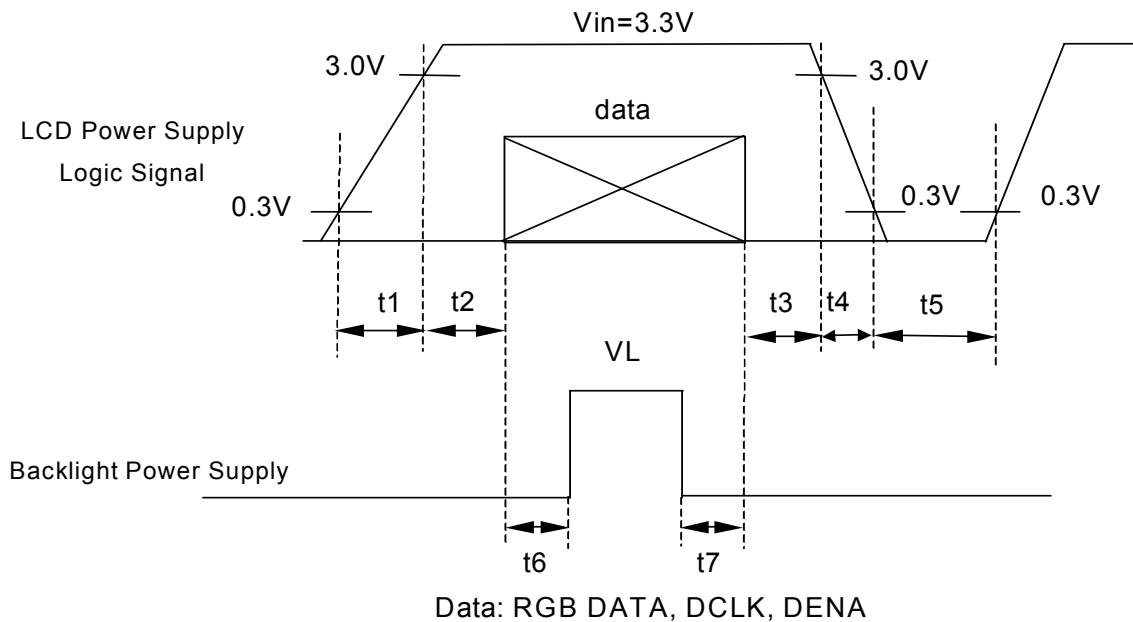

4. INTERFACE CONNECTION

4.1 CN1

Connector type : 093F30-B0B01A or compatible

Pin No.	SYMBOL	FUNCTION
1	GND	Ground
2	V _{CC}	+3.3V Power
3	V _{CC}	+3.3V Power
4	V _{EDID}	3.3V Power for NB
5	ADJ	Adjust for LED brightness
6	CLK_EDID	EDID Clock for NB
7	DATA_EDID	EDID Data for NB
8	RXIN0-	LVDS Signal(-)—channel 0
9	RXIN0+	LVDS Signal(+)—channel 0
10	GND	Ground
11	RXIN1-	LVDS Signal(-)—channel 1
12	RXIN1+	LVDS Signal(+)—channel 1
13	GND	Ground
14	RXIN2-	LVDS Signal(-)—channel 2
15	RXIN2+	LVDS Signal(+)—channel 2
16	GND	Ground
17	RXCLKIN-	LVDS Clock Signal(-)
18	RXCLKIN+	LVDS Clock Signal(+)
19	GND	Ground
20	NC	NC
21	NC	NC
22	GND	Ground
23	GND	Ground
24	V _{LED}	Power Supply for LED(V _{LED} =5.0±0.5)
25	V _{LED}	Power Supply for LED(V _{LED} =5.0±0.5)
26	V _{LED}	Power Supply for LED(V _{LED} =5.0±0.5)
27	NC	NC
28	NC	NC
29	NC	NC
30	NC	NC

【Note】

1) ADJ adjust brightness to control Pin · Pulse duty the bigger the brighter.

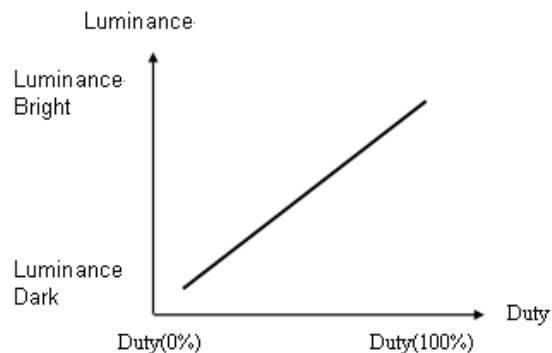

2) ADJ signal=0~3.3V · operation frequency : 25KHZ±5KHZ, ADJ pin should not connect to GND, it should pull-high if not adjust brightness.

$$F = 25\text{KHz} \pm 5\text{KHz}, T = 0.05\text{ms}$$

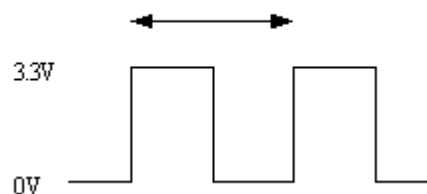

3) GND Pin must ground contact · can not be floating.

5. INPUT SIGNAL

5.1 Timing Specification

ITEM			SYMBOL	MIN	TYP	MAX	UNIT
LVDS input signal sequence	CLK Frequency		fCLKin	39.05	45	50	MHz
	CLK Period		tCLKin	25.61	22.22	19.45	ns
LCD input timing	Horizontal	Horizontal Total Time	t_H	1160	1200	1240	tCLK
		Horizontal Effective Time	t_{HA}	1024	1024	1024	tCLK
		Horizontal Blank Time	t_{HB}	136	176	216	tCLK
	Vertical	Frame	fV	55	60	65	Hz
		Vertical Total Time	t_V	612	625	638	t_H
		Vertical Effective Time	t_{VA}	600	600	600	t_H
		Vertical Blank Time	t_{VB}	12	25	38	t_H

5.2 Timing sequence (Timing chart)

5.2.1 Horizontal Timing Sequence

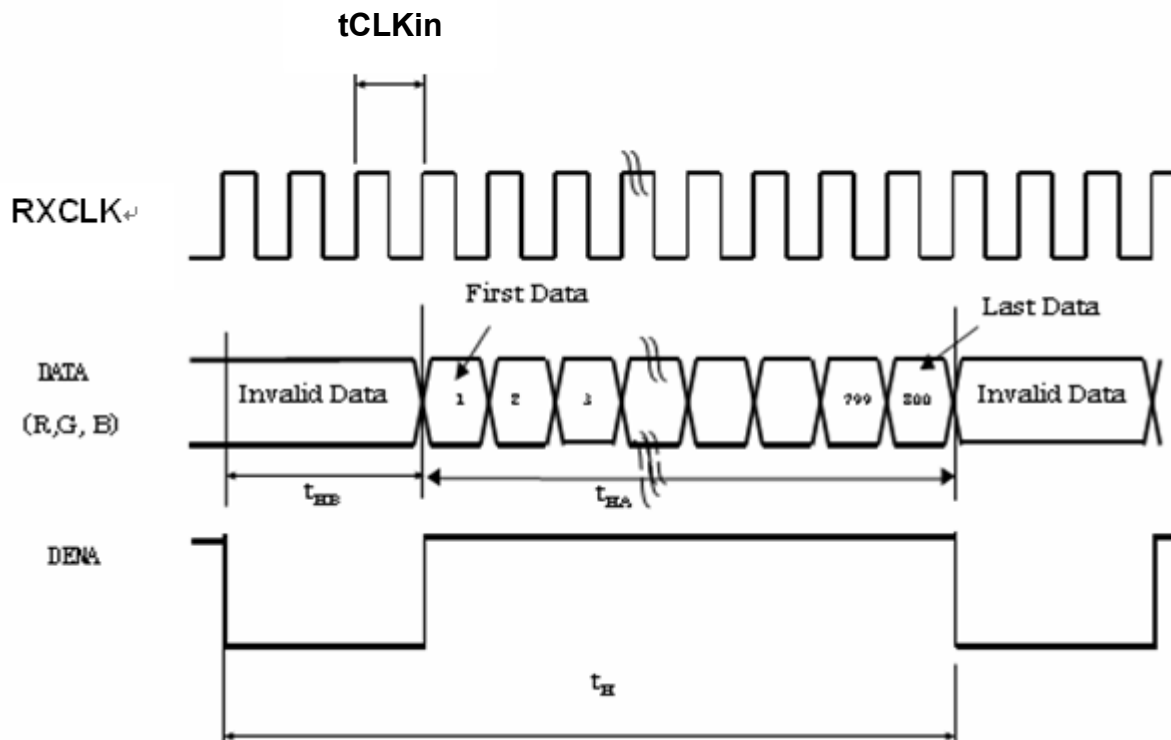

5.2.2 Vertical Timing Sequence

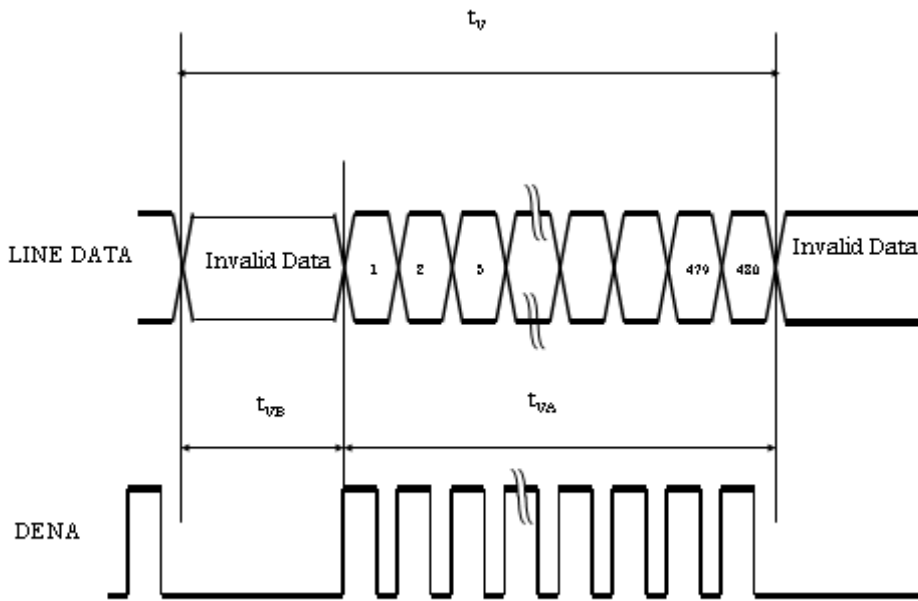

5.2.3 LVDS Input Data mapping

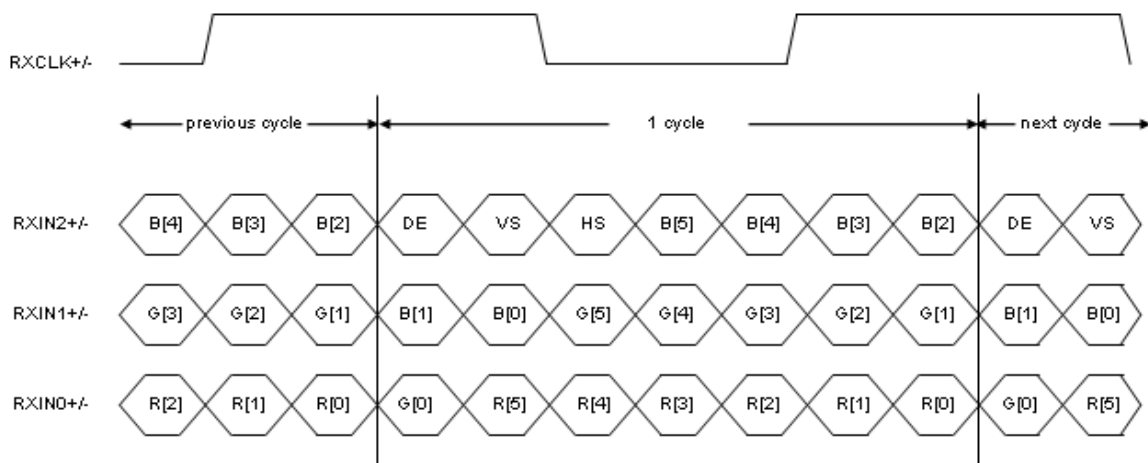

5.3 Color data assignment

COLOR	INPUT	R DATA						G DATA						B DATA					
		DATA	R5	R4	R3	R2	R1	R0	G5	G4	G3	G2	G1	G0	B5	B4	B3	B2	B1
		MSB					LSB	MSB					LSB	MSB					LSB
BASI COLOR C	BLACK	0	0	0	0	0	0	0	0	0	0	0	0	0	0	0	0	0	0
	RED(63)	1	1	1	1	1	1	0	0	0	0	0	0	0	0	0	0	0	0
	GREEN(63)	0	0	0	0	0	0	1	1	1	1	1	1	0	0	0	0	0	0
	BLUE(63)	0	0	0	0	0	0	0	0	0	0	0	0	1	1	1	1	1	1
	CYAN	0	0	0	0	0	0	1	1	1	1	1	1	1	1	1	1	1	1
	MAGENTA	1	1	1	1	1	1	0	0	0	0	0	0	1	1	1	1	1	1
	YELLOW	1	1	1	1	1	1	1	1	1	1	1	1	0	0	0	0	0	0
	WHITE	1	1	1	1	1	1	1	1	1	1	1	1	1	1	1	1	1	1
RED	RED(0)	0	0	0	0	0	0	0	0	0	0	0	0	0	0	0	0	0	0
	RED(1)	0	0	0	0	0	1	0	0	0	0	0	0	0	0	0	0	0	0
	RED(2)	0	0	0	0	1	0	0	0	0	0	0	0	0	0	0	0	0	0
	RED(62)	1	1	1	1	1	0	0	0	0	0	0	0	0	0	0	0	0	0
	RED(63)	1	1	1	1	1	1	0	0	0	0	0	0	0	0	0	0	0	0
GREEN	GREEN(0)	0	0	0	0	0	0	0	0	0	0	0	0	0	0	0	0	0	0
	GREEN(1)	0	0	0	0	0	0	0	0	0	0	0	1	0	0	0	0	0	0
	GREEN(2)	0	0	0	0	0	0	0	0	0	0	1	0	0	0	0	0	0	0
	GREEN(62)	0	0	0	0	0	0	1	1	1	1	1	0	0	0	0	0	0	0
	GREEN(63)	0	0	0	0	0	0	1	1	1	1	1	1	0	0	0	0	0	0
BLUE	BLUE(0)	0	0	0	0	0	0	0	0	0	0	0	0	0	0	0	0	0	0
	BLUE(1)	0	0	0	0	0	0	0	0	0	0	0	0	0	0	0	0	0	1
	BLUE(2)	0	0	0	0	0	0	0	0	0	0	0	0	0	0	0	0	1	0
	BLUE(62)	0	0	0	0	0	0	0	0	0	0	0	0	1	1	1	1	1	0
	BLUE(63)	0	0	0	0	0	0	0	0	0	0	0	0	1	1	1	1	1	1

【Note1】 Definition of Gray Scale

color(n) : n is series of Gray Scale. The more n value is, the bright Gray Scale.

【Note2】 Data:1-High,0-Low

6. BLOCK DIAGRAM

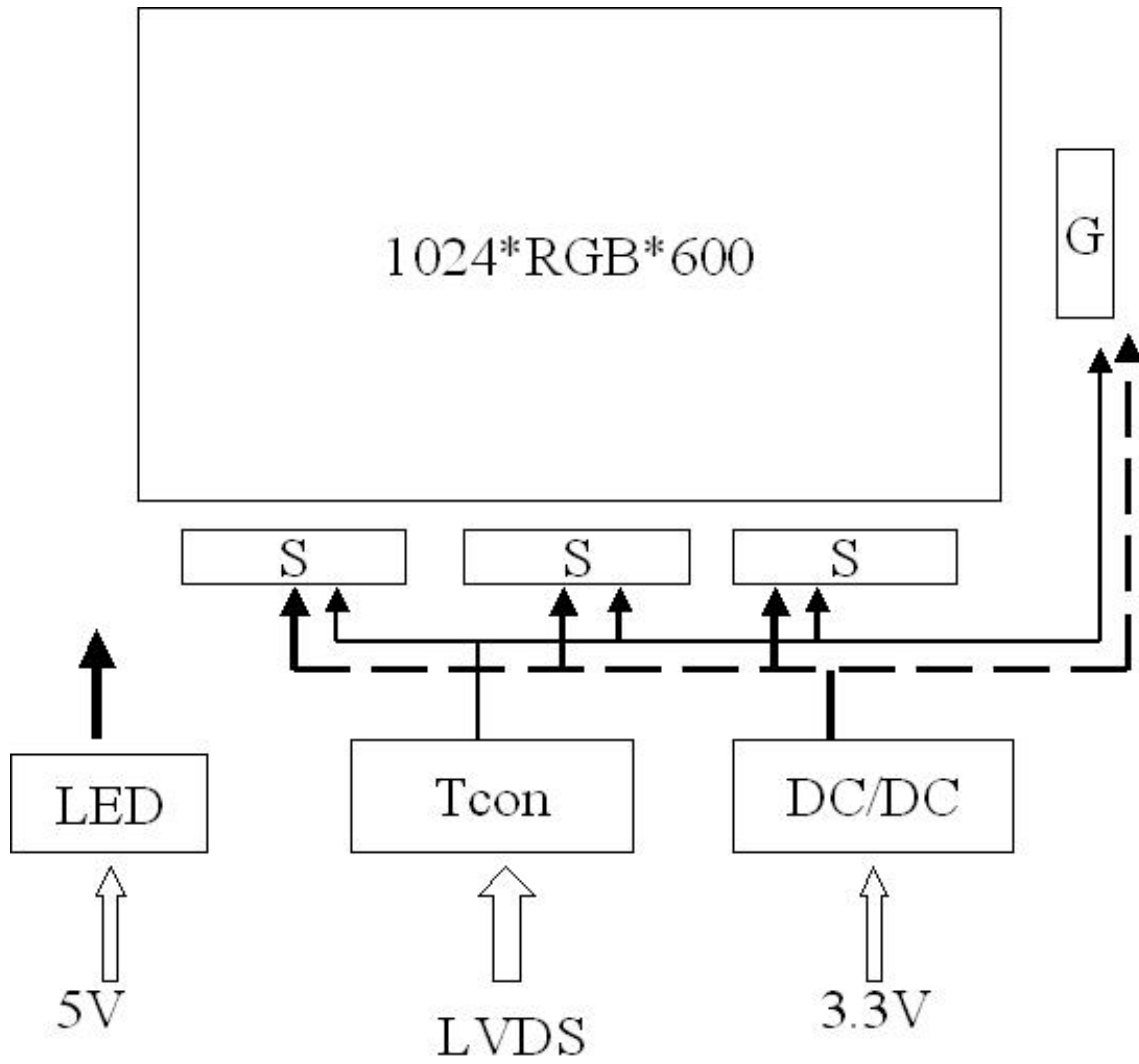

7. MECHANICAL DIMENSION

7.1 Front Side

[Unit : mm]

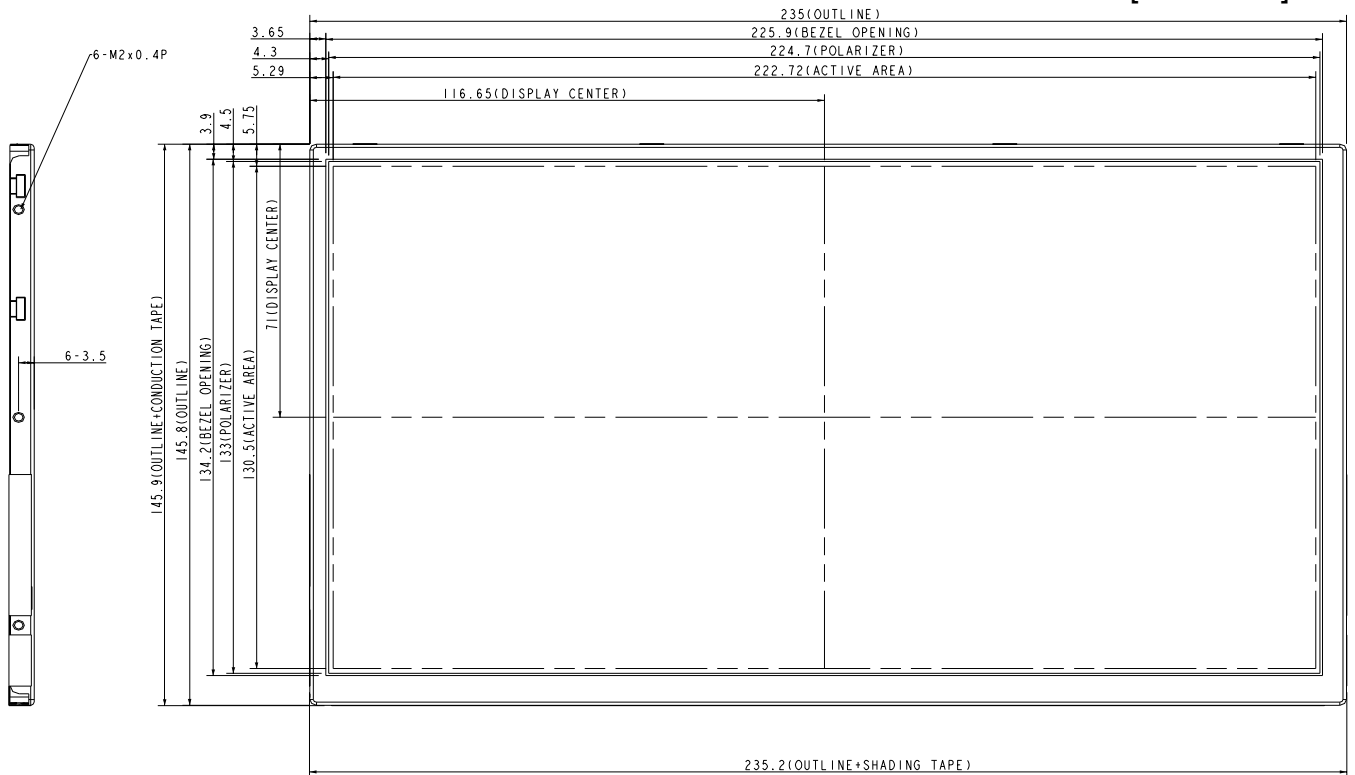

[Note] : Tolerance is $\pm 0.3\text{mm}$ unless noted

7.2 Rear Side

[Unit : mm]

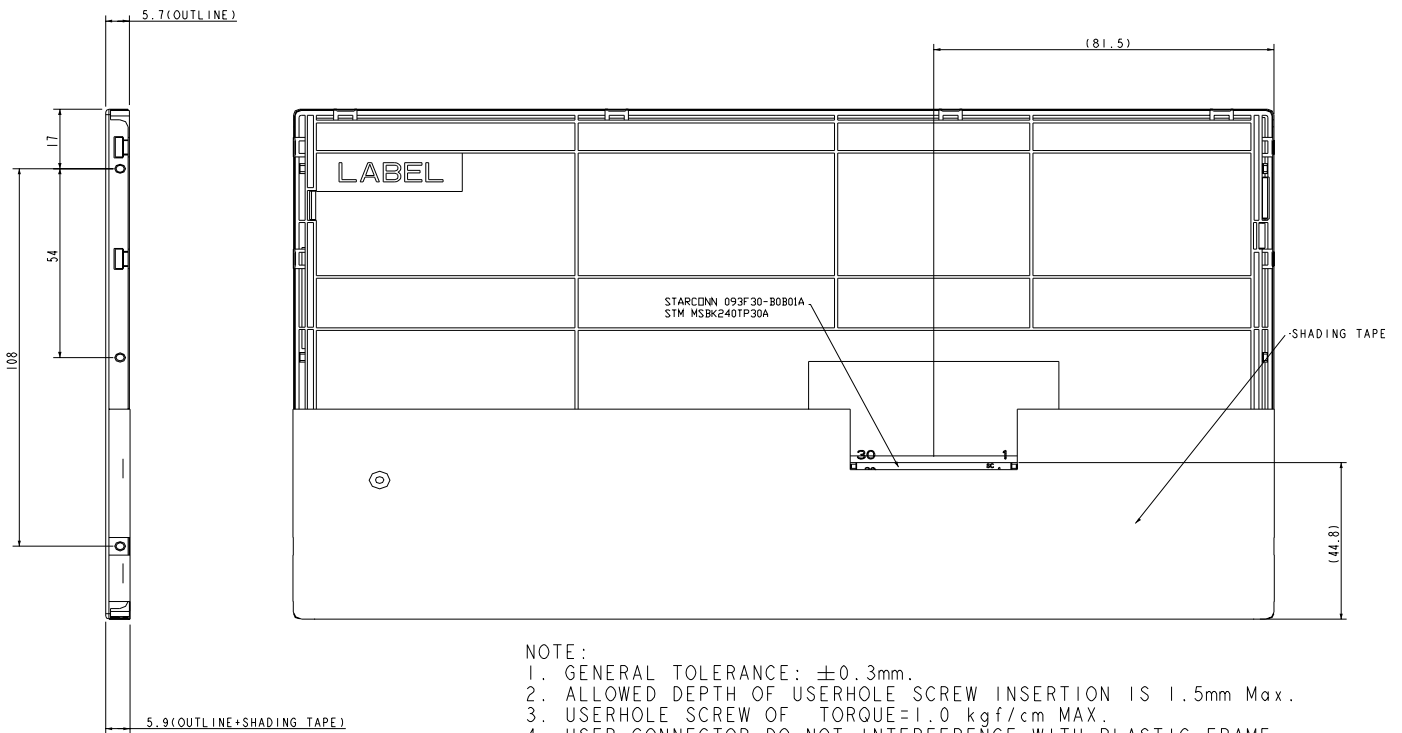

- NOTE :
1. GENERAL TOLERANCE: $\pm 0.3\text{mm}$.
 2. ALLOWED DEPTH OF USERHOLE SCREW INSERTION IS 1.5mm Max.
 3. USERHOLE SCREW OF TORQUE=1.0 kgf/cm MAX.
 4. USER CONNECTOR DO NOT INTERFERENCE WITH PLASTIC FRAME.

[Note] : Tolerance is $\pm 0.3\text{mm}$ unless noted

8. OPTICAL CHARACTERISTICS

Ta = 25°C, V_{CC} = 3.3V

ITEM		SYMBOL	CONDITION	MIN	TYP	MAX	UNIT	NOTE
Constrast Ratio		CR	Point-5	320	400	--	--	*1)*2)*3)
Luminance*)		Lw	Point-5	200	220	--	cd/m ²	*1)*3)
Luminance Uniformity		ΔL		70	80		%	*1)*3)
Response Time (White - Black)		Tr+ Tf	Point-5	--	20	30	ms	*1)*3)*5)
Viewing Angle	Horizontal	ψ	CR ≥ 10 Point-5	110	140	--	°	*1)*2)*4)
	Vertical	θ		100	120	--	°	*1)*2)*4)
Color Coordinate	White	Wx Wy	θ = φ = 0° Point-5	0.273 0.289	0.313 0.329	0.353 0.369	--	*1)*3)
	Red	Rx Ry		0.541 0.315	0.571 0.345	0.601 0.375		
	Green	Gx Gy		0.306 0.540	0.336 0.570	0.366 0.600		
	Blue	Bx By		0.123 0.094	0.153 0.124	0.183 0.154		

Note :

*1)Measure condition : 25°C ± 2°C , 60 ± 10%RH , under 10 Lux in the dark room.BM-5A (TOPCON) , viewing angle 2° , V_{CC} = 3.3V , V_{LED} = 5V.

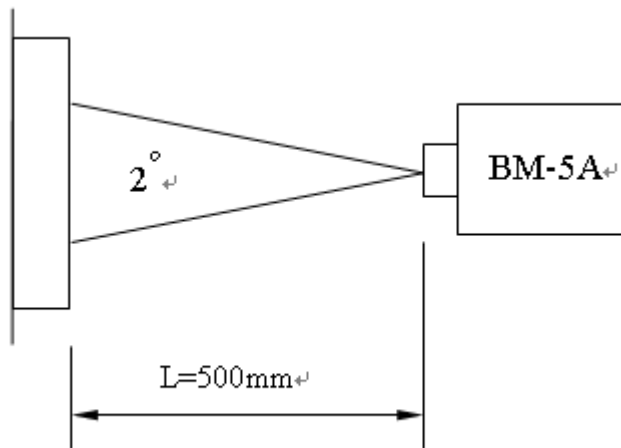

*2) Definition of contrast ratio :

Contrast Ratio (CR)= (White) Luminance of ON ÷ (Black) Luminance of OFF

- 3) Definition of luminance : Measure white luminance on the point 5 as figure8-1
 Definition of Luminance Uniformity: Measure white luminance on the point1~9 as figure8-1
 $\Delta L = [L(\text{MIN})/L(\text{MAX})] \times 100$

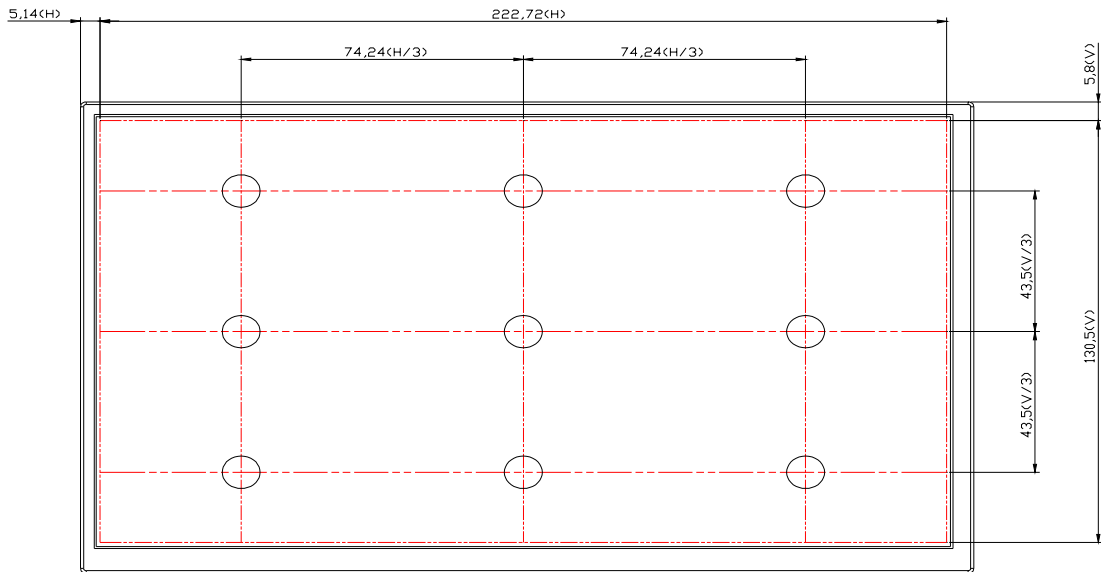

Fig8-1 Measuring point

- *4) Definition of Viewing Angle(θ, ψ), refer to Fig8-2 as below :
 These items are measured by EZ-CONTRAST (ELDIM) in the dark room. (no ambient light).

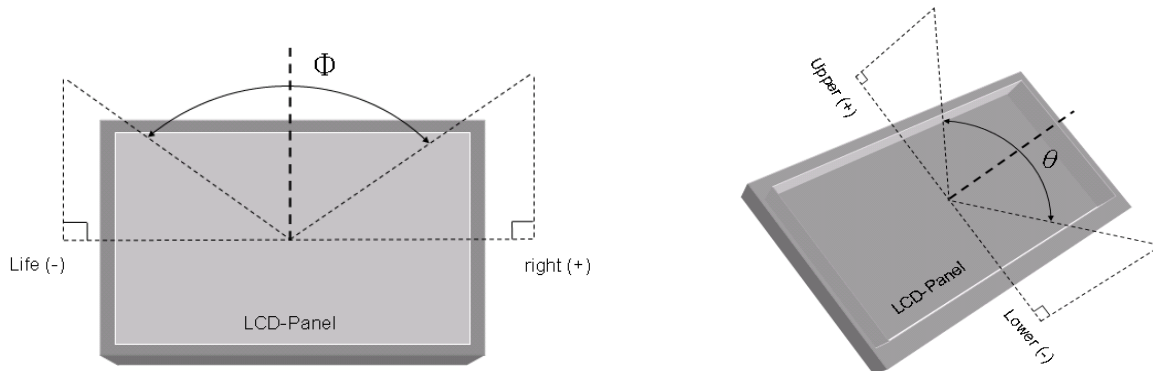

Fig8-2 Definition of Viewing Angle

- *5) Definition of Response Time.(White-Black)

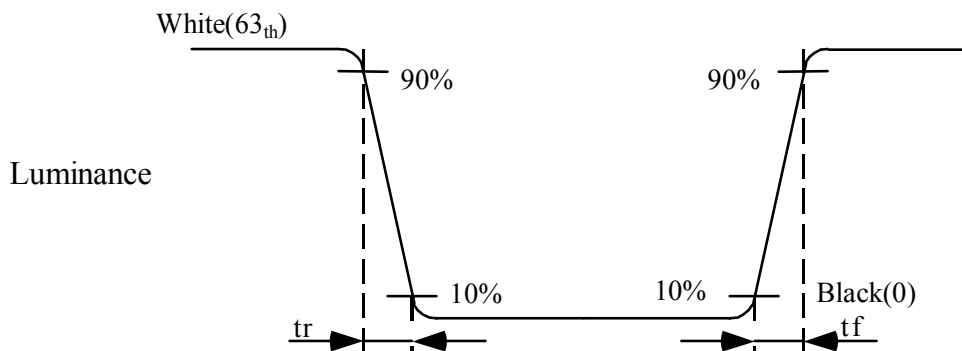

Fig8-3 Definition of Response Time(White-Black)

9. RELIABILITY TEST

9.1. Temperature and humidity

TEST ITEMS	CONDITIONS	NOTE
High Temperature Operation	70°C , 240Hrs	
High Temperature Storage	80°C , 240Hrs	
High Temperature High Humidity Operation	60°C , 90%RH , 240Hrs	No condensation
Low Temperature Operation	-30°C , 240Hrs	
Low Temperature Storage	-40°C , 240Hrs	
Thermal Shock	-30°C (0.5Hr) ~ 80°C(0.5Hr) 200 cycles	

9.2. Shock and Vibration

TEST ITEMS	CONDITIONS
Shock (Non-operation)	<ul style="list-style-type: none"> ● Shock level:980m/s²(equal to 100G) ● Waveform:half sinusoidal wave,6ms. ● Number of shocks:one shock input in each direction of three mutually perpendicular axes for a total of three shock inputs.
Vibration (Non-operation)	<ul style="list-style-type: none"> ● Frequency range:8~33.3Hz ● Stroke:1.3mm ● Vibration:sinusodial wave,perpendicularaxis(both x, z axis:2Hrs, y axis 4Hrs). ● Sweep:2.9G,33.3Hz-400Hz ● Cycle:15min

9.3. ESD Test

ITEM	CONDITION	NOTE
ESD	150pF , 330Ω , ±8KV&±15KV air & contact test	*1)
	200pF , 0Ω , ±250V contact test	*2)

Note :

*1) LCD glass and metal bezel

*2) IF connector pins

9.4 Judgment Standard

The Judgment of the above test should be made as follow:

Pass:Normal display image with no obvious non-uniformity and no line defect.Partial transformation of the module parts should be ignored.

Fail:No display image,obvious non-uniform,or line defect.

10. RELIABILITY TEST

10.1 Incoming inspection right

- (1) The Incoming Inspection Standard will be agreed and signed by both sides (Customer and CPT) before CPT receives the PO (Purchase Order) forward 7 days.
- (2) The Customer shall notify CPT inspection result in writing within 21 day, otherwise goods will be deemed accepted by customer.

10.2 Inspection conditions is as follows:

- (1) Viewing distance is approximately 35 ~ 40 cm
- (2) Viewing angle is normal to the LCD panel as Fig_1 (10°)
- (3) Ambient temperature is approximately $25 \pm 5^\circ\text{C}$
- (4) Ambient humidity is $60 \pm 5\% \text{ RH}$
- (5) Ambient illuminance is from 300 ~ 500 Lux.
- (6) Input signal timing should be typical value.

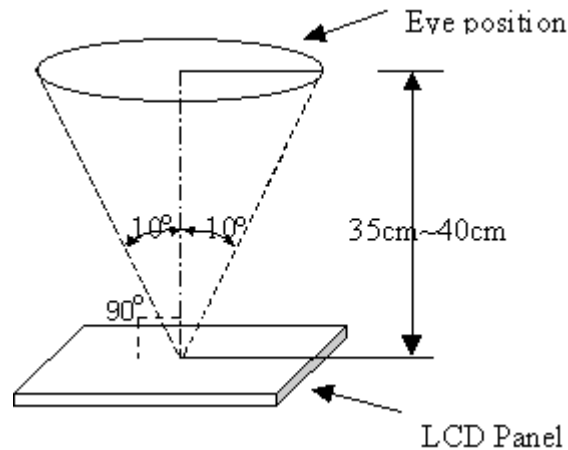

Fig_1

10.3 Special condition

- (1) Viewing distance is close for inspection of adjacent dots and distance between defect dots.
- (2) Viewing condition of "Shot block non-uniformity from oblique angle" is as Fig_2.
- (3) Exceptional case: View angle $\pm 40^\circ$ while inspected image-sticking.

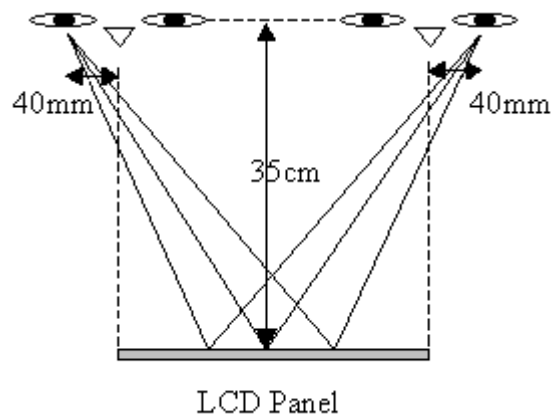

Fig_2

10.4 Inspection Criteria

DEFECT TYPE		LIMIT		Note	
VISUAL DEFECT	SCRATCH		$0.03\text{mm} \leq W \leq 0.2\text{mm}$	$N \leq \infty$	--
	INTERNAL	SPOT	$0.15\text{mm} \leq \phi \leq 0.5\text{mm}$	$N \leq 4$	*1)
		FIBER	$W \leq 1.0\text{mm}, L \leq 1.5\text{mm}$	$N \leq 4$	*1)
		POLARIZER BUBBLE	$0.15\text{mm} \leq \phi \leq 0.5\text{mm}$	$N \leq 4$	*1)
		TOTAL	$N \leq 8$		--
ELECTRICAL DEFECT	BRIGHT DOT		$N \leq 2$		*2)
	DARK DOT		$N \leq 4$		--
	TOTAL DOT		$N \leq 4$		*2)
	TWO ADJACENT DOT		≤ 1 PAIRS		*3)
	THREE OR MORE ADJACENT DOT		NOT ALLOWED		--
	DISTANCE BETWEEN DEFECT DOT	Two bright dots		$\geq 15\text{mm}$	*4)
		Bright dot and dark dot		$\geq 5\text{mm}$	*4)
		Two dark dots		$\geq 5\text{mm}$	*4)
	LINE DEFECT		NOT ALLOWED		--
MURA		$\leq 5\%$ ND filter		--	

One pixel consists of 3 sub-pixels, including R,G, and B dot.(Sub-pixel = Dot)

[Note1] W : Width[mm], L : Length[mm], N : Number, ϕ : Average Diameter

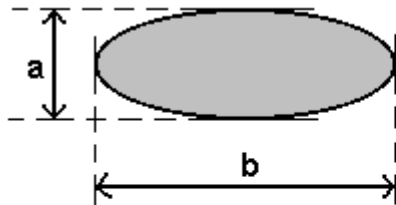

- 1. (White, black) Spot
- 2. Polarizer Bubble

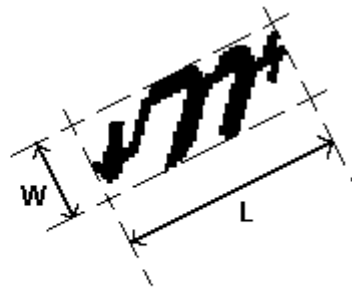

- 1. Fiber

[Note2] Bright dot is defined through 5% transmission ND Filter as following.

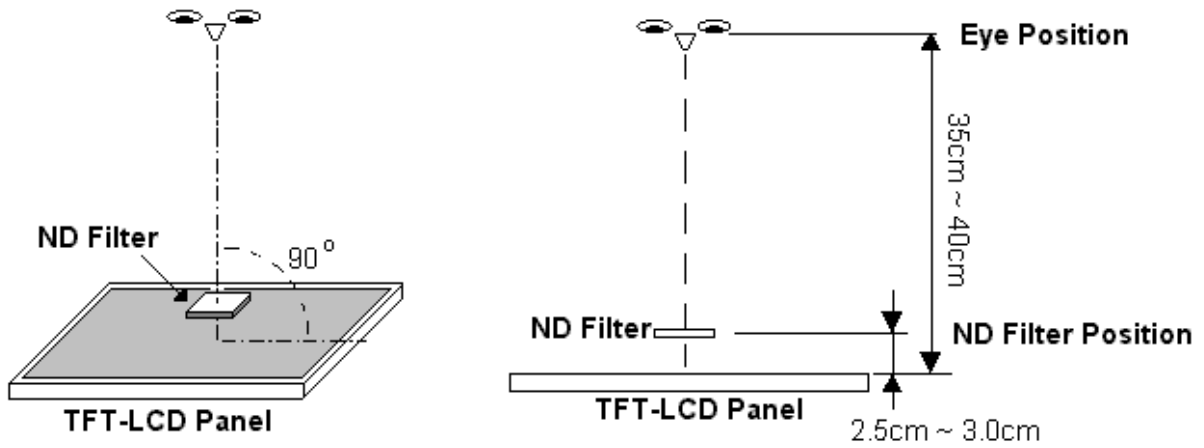

[Note3] Judge defect dot and adjacent dot as following. Allow below (as A, B, C and D status) adjacent defect dots, including bright and dart adjacent dot. And they will be counted 2 defect dots in total quantity.

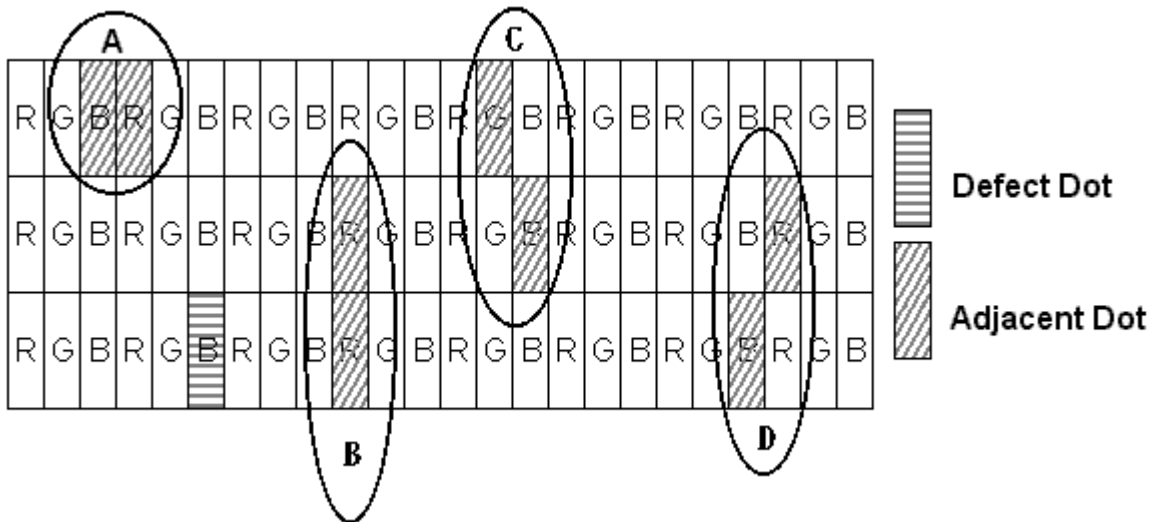

[Note4] Definition of distance between defect dot as following.

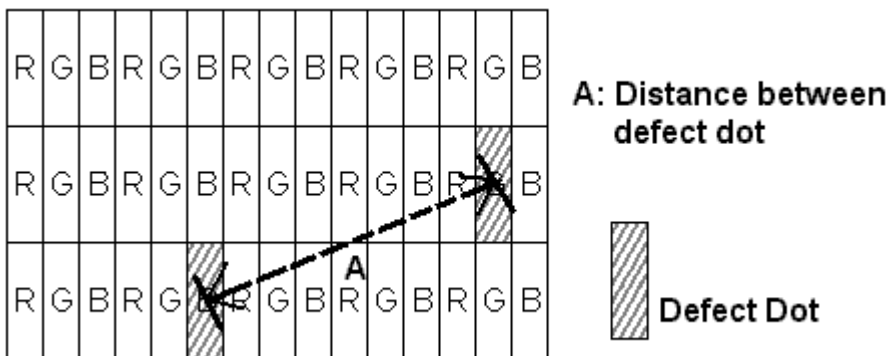

[Note 5] Other

- (1) The defects that are not defined above and considered to be problem shall be reviewed and discussed by both parties.
- (2) Defects on the Black Matrix, out of Display area, are not considered as a defect or counted.

10.5 Mechanical :

- (1) Regarding the mechanical dimension, please refer the Technical Specification.
 - a. The tolerance of mechanical dimension is $\pm 0.5\text{mm}$.
 - b. And the tolerance of length of lamp cable is $\pm 5.0\text{mm}$.
 - c. The gap between Bezel and Glass is $0.6\text{mm}(\text{Max})$.

10.6 Handling precaution

- (1) Don't disassemble and reassemble the module by self.
- (2) Acid, alkali, alcohol or touched directly by hand will damage the display.
- (3) Static electricity will damage the module. Please configure grounding device.
- (4) The strong vibration, shock, twist or bend will cause material damage, even module broken.
- (5) It is easy to cause image sticking while displaying the same pattern for very long time.
 - (6) The response time, brightness and performance will vary from different temperature.