



# Chunghwa Picture Tubes, Ltd. Product Specification

To :

Date :

*TFT LCD*

**CLAA101NA0ACN**

ACCEPTED BY :

APPROVED BY	CHECKED BY	PREPARED BY

Prepared by :

Product Planning Management Division

**CHUNGHWA PICTURE TUBES, LTD.**

1127 Hopin Rd., Padeh, Taoyuan, Taiwan 334, R.O.C.

TEL: +886-3-3675151 FAX: +886-3-377-3003

Doc.No:	CLAA101NA0ACN-V1	Issue Date:	
---------	------------------	-------------	--

### REVISION STATUS

Revision Notice	Description	Page	Rev. Date
V 1	First revision		2008.11.28

---

## CONTENTS

1. OVERVIEW.....	4
2. ABSOLUTE MAXIMUM RATINGS .....	5
3. ELECTRICAL CHARACTERISTICS.....	6
4. INTERFACE CONNECTION.....	9
5. INPUT SIGNAL (DE MODE ONLY) .....	11
6. BLOCK DIAGRAM.....	14
7. MECHANICAL DIMENSION .....	15
8. OPTICAL CHARACTERISTICS.....	16
9. RELIABILITY TEST .....	18

## 1. OVERVIEW

**CLAA101NA0ACN** is 25.5cm(10.1") color TFT-LCD (Thin Film Transistor Liquid Crystal Display) module composed of LCD panel, driver ICs, control circuit and LED backlight. By applying 1024×576 images are displayed on the 10.1" diagonal screen. Display 262K colors by 6 Bit R.G.B signal input. Use 3.3 voltage to drive the power of LCD system.

General specification are summarized in the following table:

ITEM	SPECIFICATION
Display Area (mm)	222.72(H) x 125.28(V) (10.1-inch diagonal)
Number of Pixels	1024(H) × 3(RGB) × 576(V)
Pixel Pitch (mm)	0.2175 (H) × 0.2175 (V)
Color Pixel Arrangement	RGB vertical stripe
Display Mode	Normally white, TN
Number of Colors	262,144
Optimum Viewing Angle	6 o'clock
Brightness (cd/m <sup>2</sup> )	200nit(typ.)
Response Time (Tr+Tf)	25ms (typ.)
Viewing Angle(BL on,CR <sub>≥</sub> 10)	L/R:45/45 degree
	U/D:15/30 degree
Power Consumption (W)	3.0 (Max.)
Electrical Interface(data)	LVDS
Module Size (mm)	235.5(W)x143.5(H)x5.2(D)(max.)
Module Weight (g)	200(Typ.)
Backlight Unit	LED
Surface Treatment	Anti-Glare type , Hardness:3H

## 2. ABSOLUTE MAXIMUM RATINGS

The following are maximum values which, if exceeded, may cause faulty operation or damage to the unit.

ITEM	SYMBOL	MIN.	MAX.	UNIT	NOTE
Power Supply Voltage	V <sub>cc</sub>	-0.3	4.0	V	
LED Supply Voltage	V <sub>LED</sub>	-0.3	25.0	V	
Static Electricity	V <sub>ESDc</sub>	-200	200	V	【 Note2】
	V <sub>ESDm</sub>	-15K	15K	V	
ICC Rush Current	IRUSH	-	1	A	【 Note 3】
Operation Temperature	T <sub>op</sub>	0	50	°C	【 Note 1】
Storage Temperature	T <sub>stg</sub>	-20	60	°C	【 Note 1】

【 Note】

【 Note1】 If users use the product out off the environment operation range ( temperature and humidity ) ,it will concern for visual quality.

【 Note2】 Test Condition: IEC 61000-4-2 ,  
 V<sub>ESDc</sub> : Contact discharge to input connector  
 V<sub>ESDm</sub> : Discontact discharge to module

【 Note3】 The input pulse-current measurement system as below :

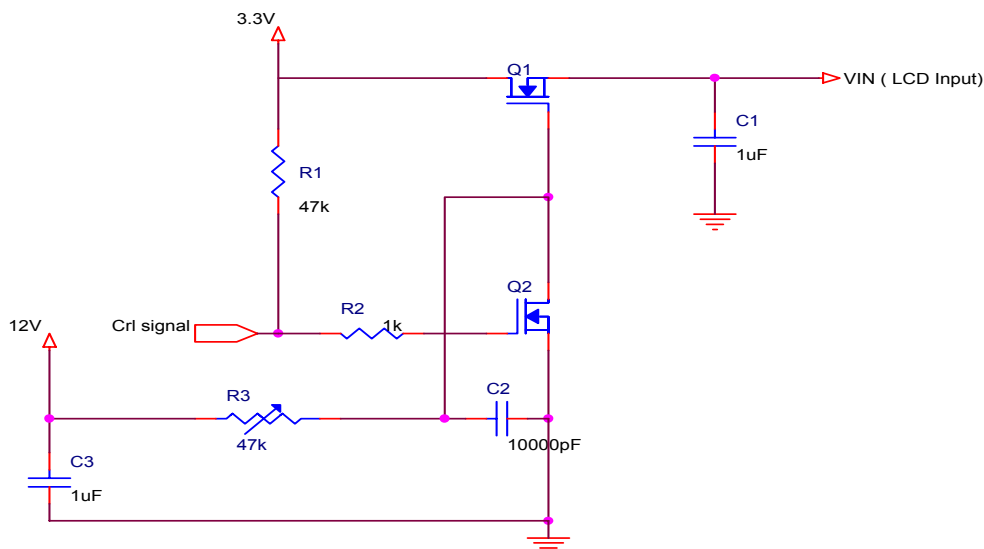

Control signal:High(+3.3V)→Low(GND)

Supply Voltage of rising time should be from R3 and C2 tune to 550 us.

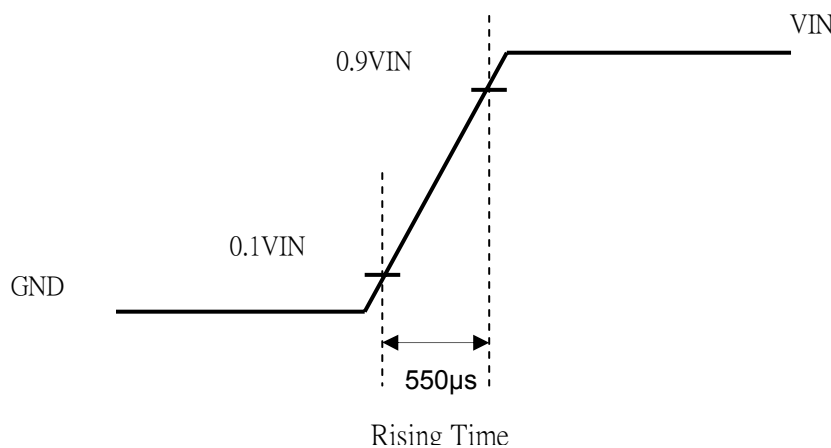

### 3. ELECTRICAL CHARACTERISTICS

#### 3.1 TFT LCD Power Voltage

 $T_a=25^{\circ}\text{C}$ 

ITEM	SYMBOL	MIN.	TYP.	MAX.	UNIT	NOTE	
Power Supply Voltage For LCD	$V_{CC}$	3.0	3.3	3.6	V		
Power Supply Voltage For LED	$V_{LED}$	5.0	12	21.0	V		
Logic Input Voltage (LVDS:IN+,IN-)	Input Voltage	$V_{IN}$	0	-	$V_{CC}$	V	【Note 1】
	Common Mode Voltage	$V_{CM}$	1.08	1.2	1.32	V	【Note 1】
	Differential Input Voltage	$ VID $	250	350	450	mV	【Note 1】
	Threshold Voltage(high)	$V_{TH}$	-	-	100	mV	【Note 1】
	Threshold Voltage(low)	$V_{TL}$	-100	-	-	mV	【Note 1】
ADJ Input Voltage	Input Voltage(high)	$V_{IH}$	3.0	3.3	V		
	Input Voltage(low)	$V_{IL}$	GND	0.3	V		

【Note】

【Note1】 LVDS signal

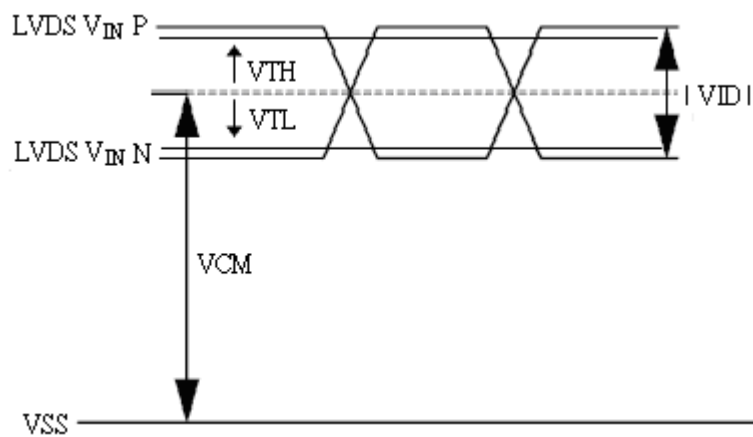

### 3.2 TFT-LCD Current Consumption

ITEM	SYMBOL	MIN.	TYP.	MAX.	UNIT	NOTE
LCD Power Current	$I_{CC}$	--	250	300	mA	【Note1】
LED Power Current	$I_{LED}$	--	160	175	mA	【Note2】

【Note1】 Typical: Under 64 gray pattern @  $V_{CC} = 3.3\text{ V}$  & Frame rate is 60 Hz.  
 Maximum: Under black pattern @  $V_{CC} = 3.0\text{ V}$  & Frame rate is 60 Hz.

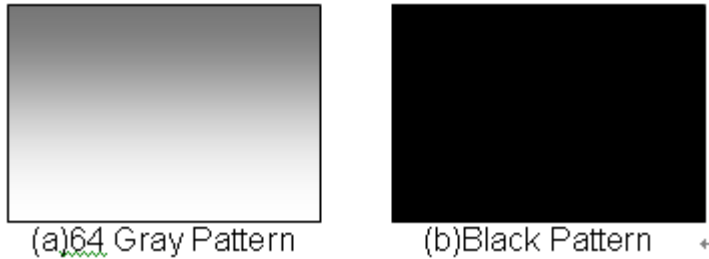

【Note2】  $V_{LED} = 12\text{ V}$  ; ADJ high pulse is 100 %

### 3.3 Power 、Signal sequence

- $0.5 < t_1 \leq 10\text{ms}$
- $0 < t_2 \leq 50\text{ms}$
- $0 < t_3 \leq 50\text{ms}$
- $0 < t_4 \leq 10\text{ms}$
- $200\text{ms} \leq t_5$
- $200\text{ms} \leq t_6$
- $200\text{ms} \leq t_7$

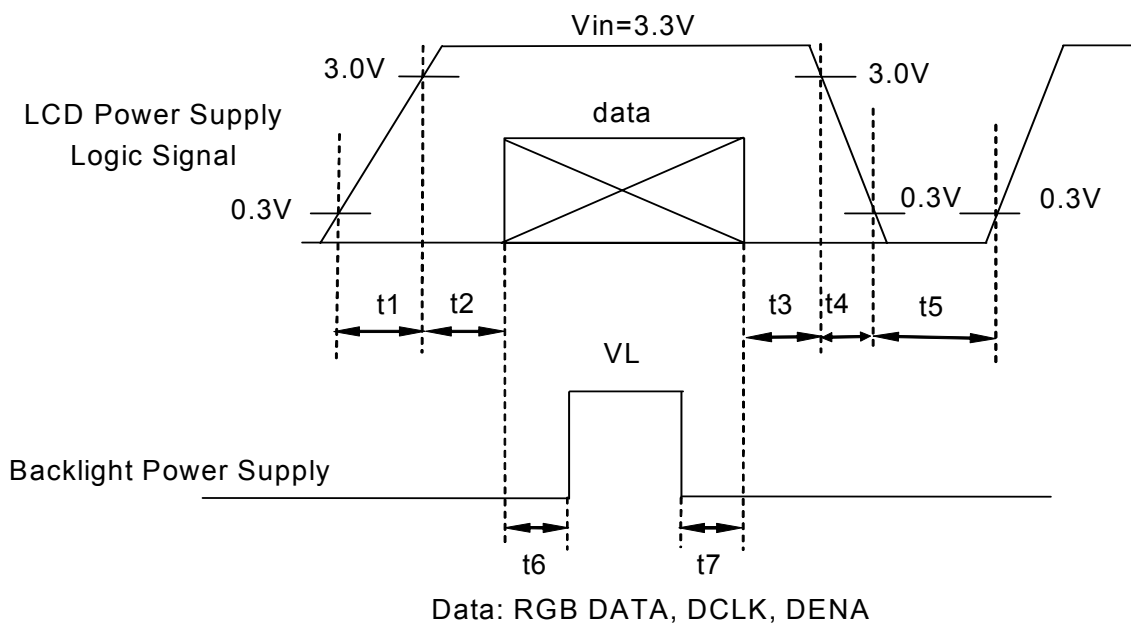

3.4 LED ON/OFF Sequence:

- 10ms  $\leq$  t1
- 10ms  $\leq$  t2
- 0ms  $\leq$  t3
- 10ms  $\leq$  t4

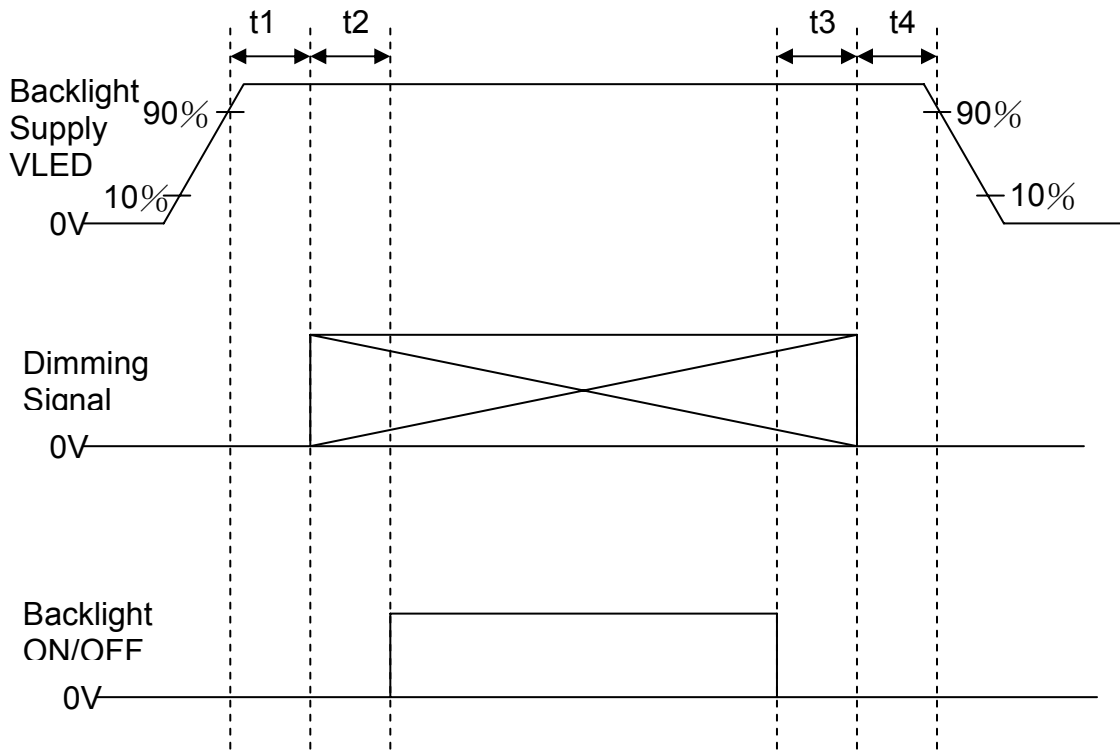

3.5 Backlight :

Ta=25°C

ITEM	SYMBOL	MIN	TYP	MAX	UNIT	NOTE
LED Lift Time	N/A	10,000			Hour	IF=20mA



## 4. INTERFACE CONNECTION

### 4.1 CN1

Connector type : I-PEX 20455-040E-12

Pin No.	SYMBOL	FUNCTION
1	NC	NC
2	V <sub>CC</sub>	+3.3V Power
3	V <sub>CC</sub>	+3.3V Power
4	V <sub>EDID</sub>	EDID 3.3V Power
5	BIST	
6	CLK <sub>EDID</sub>	EDID Clock
7	DATA <sub>EDID</sub>	EDID Data
8	RXIN0-	LVDS Signal(-)—channel 0
9	RXIN0+	LVDS Signal(+)—channel 0
10	GND	Ground
11	RXIN1-	LVDS Signal(-)—channel 1
12	RXIN1+	LVDS Signal(+)—channel 1
13	GND	Ground
14	RXIN2-	LVDS Signal(-)—channel 2
15	RXIN2+	LVDS Signal(+)—channel 2
16	GND	Ground
17	RXCLKIN-	LVDS Clock Signal(-)
18	RXCLKIN+	LVDS Clock Signal(+)
19	GND	Ground
20	NC	NC
21	NC	NC
22	GND	Ground
23	NC	NC
24	NC	NC
25	GND	Ground
26	NC	NC
27	NC	NC
28	GND	Ground
29	NC	NC
30	NC	NC
31	GND	Ground
32	GND	Ground
33	GND	Ground
34	NC	NC
35	ADJ	Adjust for LED brightness
36	LED-EN	LED Enable pin(+3V Input)
37	NC	NC
38	V <sub>LED</sub>	Power Supply for LED(V <sub>LED</sub> =5V-21V)
39	V <sub>LED</sub>	Power Supply for LED(V <sub>LED</sub> =5V-21V)
40	V <sub>LED</sub>	Power Supply for LED(V <sub>LED</sub> =5V-21V)

**【Note】**

1) ADJ adjust brightness to control Pin , Pulse duty the bigger the brighter.

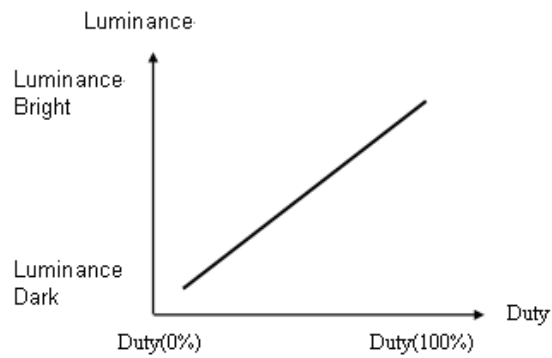

2) ADJ signal=0~3.3V, operation frequency : 100HZ~20KHz. ADJ pin should not connect to GND, it should pull-high if not adjust brightness.

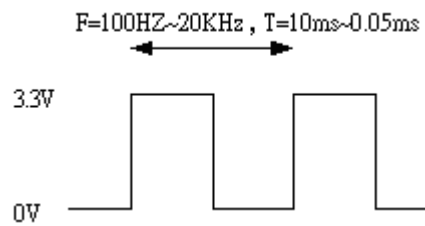

3) GND Pin must ground contact , can not be floating.

### 5. INPUT SIGNAL (DE MODE ONLY)

#### 5.1 Timing Specification:

ITEM			SYMBOL	MIN.	TYP.	MAX.	UNIT
LVDS input signal sequence	CLK Frequency		fCLKin	33	45	60-	MHz
	CLK Period		tCLKin	16.6	22.22	30.3	ns
LCD input timing	Horizontal	Horizontal Total Time	t <sub>H</sub>	1074	1200	1430	tCLK
		Horizontal Effective Time	t <sub>HA</sub>	--	1024	--	tCLK
		Horizontal Blank Time	t <sub>HB</sub>	50	176	406	tCLK
	Vertical	Frame	fV	50	60	65	Hz
		Vertical Total Time	t <sub>V</sub>	628	628	646	t <sub>H</sub>
		Vertical EffectiveTime	t <sub>VA</sub>	--	576	--	t <sub>H</sub>
		Vertical Blank Time	t <sub>VB</sub>	52	52	70	t <sub>H</sub>

#### 5.2 Timing sequence (Timing chart)

##### 5.2.1 Horizontal Timing Sequence

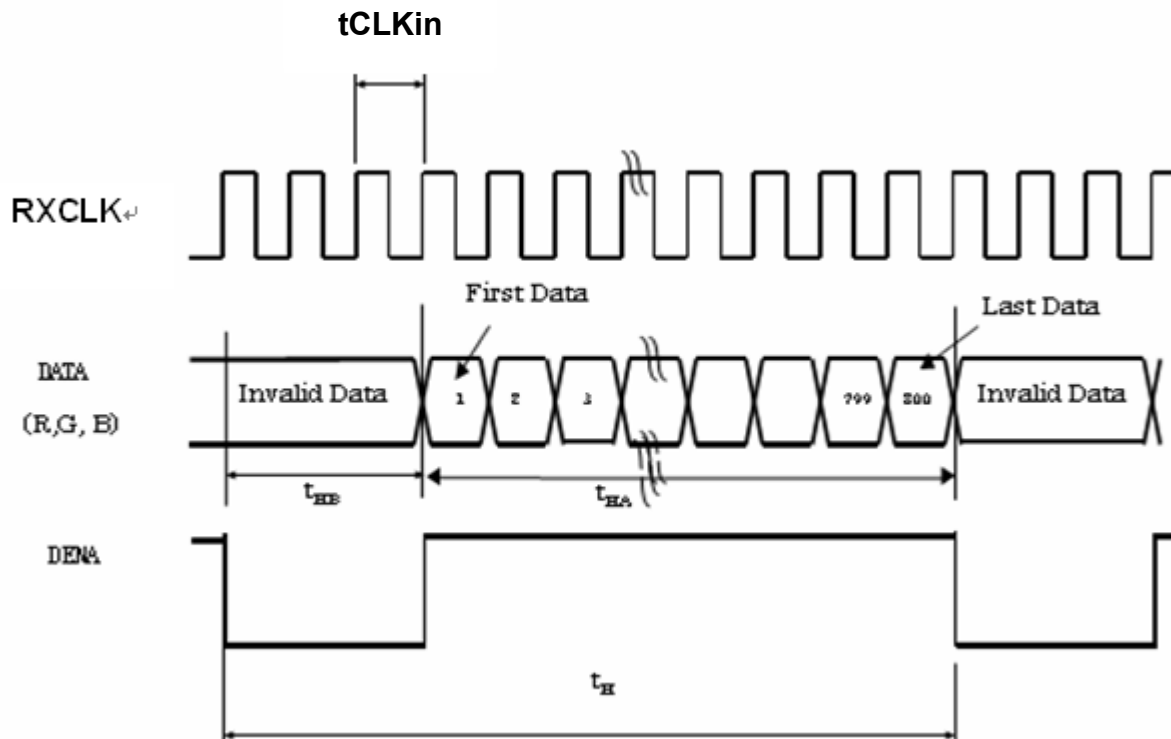

### 5.2.2 Vertical Timing Sequence

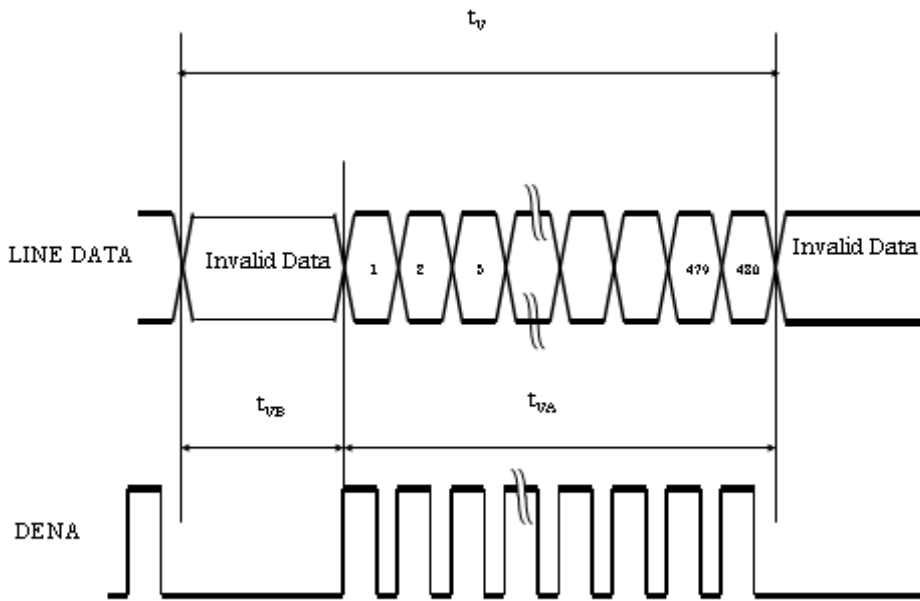

### 5.2.3 LVDS Input Data mapping

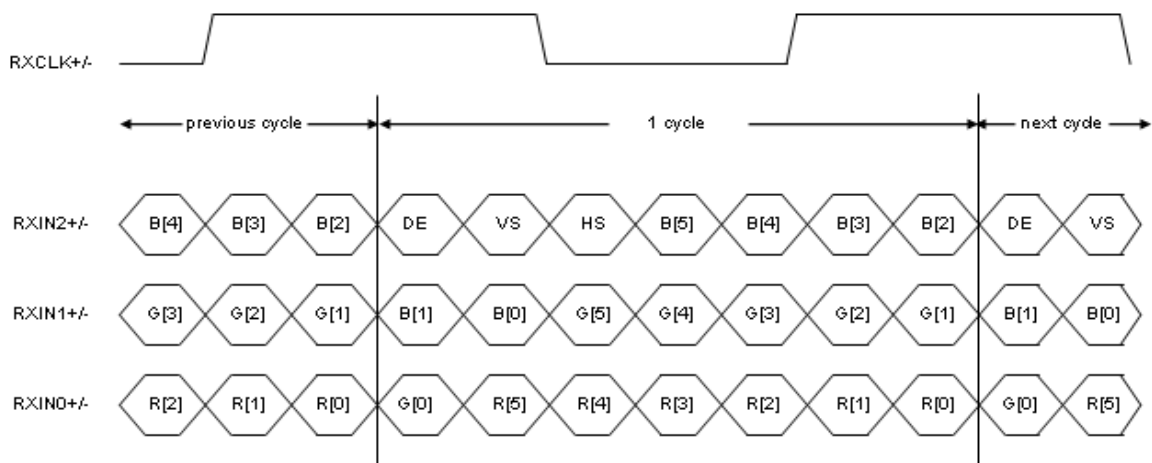

5.3 Color data assignment

COLOR	INPUT	R DATA						G DATA						B DATA					
		R5	R4	R3	R2	R1	R0	G5	G4	G3	G2	G1	G0	B5	B4	B3	B2	B1	B0
	DATA	MSB					LSB	MSB					LSB	MSB					LSB
BASIC COLOR	BLACK	0	0	0	0	0	0	0	0	0	0	0	0	0	0	0	0	0	0
	RED(63)	1	1	1	1	1	1	0	0	0	0	0	0	0	0	0	0	0	0
	GREEN(63)	0	0	0	0	0	0	1	1	1	1	1	1	0	0	0	0	0	0
	BLUE(63)	0	0	0	0	0	0	0	0	0	0	0	0	1	1	1	1	1	1
	CYAN	0	0	0	0	0	0	1	1	1	1	1	1	1	1	1	1	1	1
	MAGENTA	1	1	1	1	1	1	0	0	0	0	0	0	1	1	1	1	1	1
	YELLOW	1	1	1	1	1	1	1	1	1	1	1	1	0	0	0	0	0	0
	WHITE	1	1	1	1	1	1	1	1	1	1	1	1	1	1	1	1	1	1
RED	RED(0)	0	0	0	0	0	0	0	0	0	0	0	0	0	0	0	0	0	0
	RED(1)	0	0	0	0	0	1	0	0	0	0	0	0	0	0	0	0	0	0
	RED(2)	0	0	0	0	1	0	0	0	0	0	0	0	0	0	0	0	0	0
	RED(62)	1	1	1	1	1	0	0	0	0	0	0	0	0	0	0	0	0	0
	RED(63)	1	1	1	1	1	1	0	0	0	0	0	0	0	0	0	0	0	0
GREEN	GREEN(0)	0	0	0	0	0	0	0	0	0	0	0	0	0	0	0	0	0	0
	GREEN(1)	0	0	0	0	0	0	0	0	0	0	0	1	0	0	0	0	0	0
	GREEN(2)	0	0	0	0	0	0	0	0	0	0	1	0	0	0	0	0	0	0
	GREEN(62)	0	0	0	0	0	0	1	1	1	1	1	0	0	0	0	0	0	0
	GREEN(63)	0	0	0	0	0	0	1	1	1	1	1	1	0	0	0	0	0	0
BLUE	BLUE(0)	0	0	0	0	0	0	0	0	0	0	0	0	0	0	0	0	0	0
	BLUE(1)	0	0	0	0	0	0	0	0	0	0	0	0	0	0	0	0	0	1
	BLUE(2)	0	0	0	0	0	0	0	0	0	0	0	0	0	0	0	0	1	0
	BLUE(62)	0	0	0	0	0	0	0	0	0	0	0	0	1	1	1	1	1	0
	BLUE(63)	0	0	0	0	0	0	0	0	0	0	0	0	1	1	1	1	1	1

【Note1】 Definition of Gray Scale

color(n) : n is series of Gray Scale. The more n value is the bright Gray Scale.

【Note2】 Data:1-High, 0-Low.

### 6. BLOCK DIAGRAM

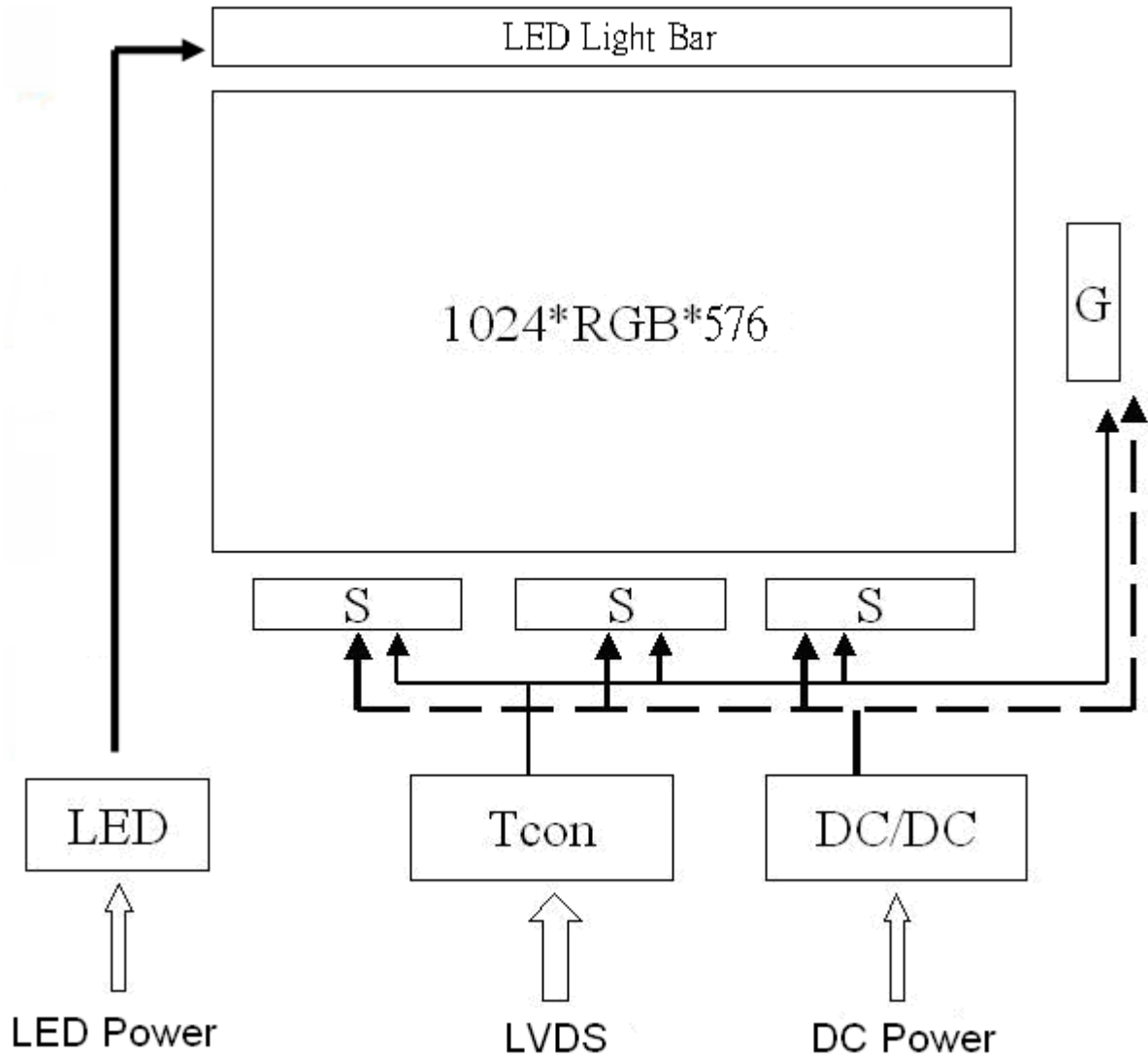

### 7. MECHANICAL DIMENSION

#### 7.1 Front Side

[Unit : mm]

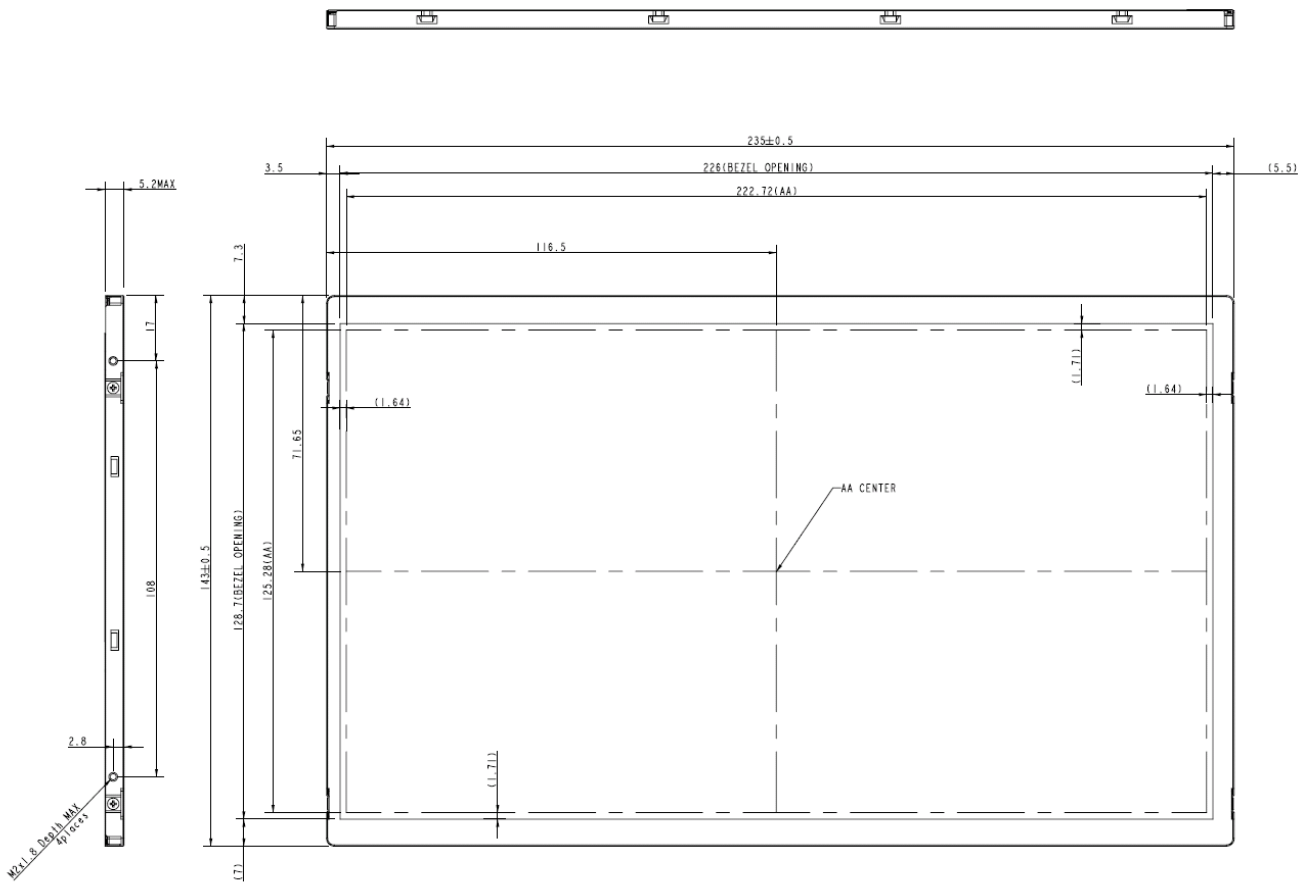

[Note] : Tolerance is ±0.3mm unless noted

#### 7.2 Rear Side

[Unit : mm]

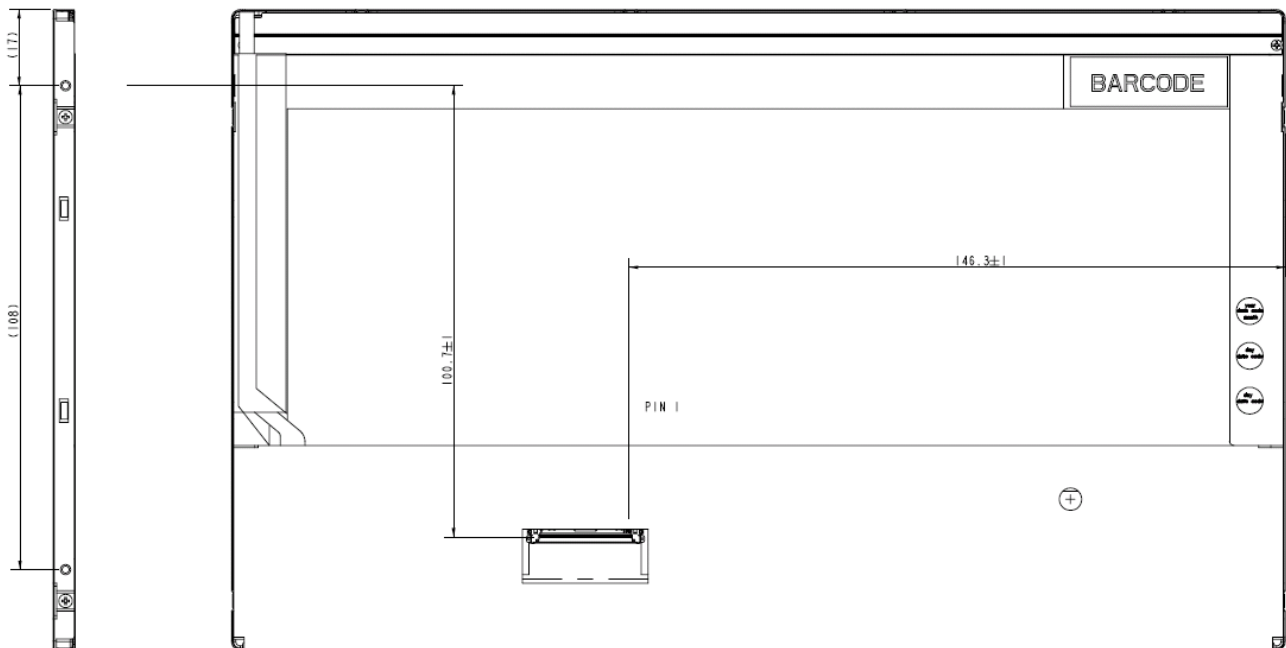

[Note] : 1.Tolerance is ±0.3mm unless noted  
 2.SCREW TORQUE Maximum= 2.0kgf-cm

## 8. OPTICAL CHARACTERISTICS

Ta = 25°C, V<sub>CC</sub> = 3.3V

ITEM		SYMBOL	CONDITION	MIN.	TYP.	MAX.	UNIT	NOTE
Constrast Ratio		CR	Point-7	320	500	--	--	*1)*2)*4)
Luminance*)		Lw	5 Points Avg	170	200	--	cd/m <sup>2</sup>	*1)*3)
Luminance Uniformity		ΔL	5 Points	--	--	1.25		*1)*4)
			13 Points	--	--	1.6		*1)*5)
Response Time (White - Black)		Tr+ Tf	Point-7	--	25	30	ms	*1)*4)*7)
Viewing Angle	Horizontal	ψ	CR ≥ 10	80	90	--	°	*1)*2)*7)
	Vertical	θ	Point-7	35	45	--	°	*1)*2)*7)
Color Coordinate	White	Wx	θ = φ = 0° Point-7	0.273	0.313	0.353	--	*1)
		Wy		0.289	0.329	0.369		
	Red	Rx		0.541	0.571	0.601		
		Ry		0.303	0.333	0.363		
	Green	Gx		0.311	0.341	0.371		
		Gy		0.536	0.566	0.596		
	Blue	Bx		0.123	0.153	0.183		
		By		0.077	0.107	0.137		

### 【Note】

\*1) Measure condition: 25°C±2°C, 60±10%RH, and V<sub>LED</sub>=12V (ADJ duty100%). To be measured in the dark room(under 10 Lux). To be measured on the center area of panel with a viewing angle 2° by BM-5A (TOPCON), after 15 minutes operation.

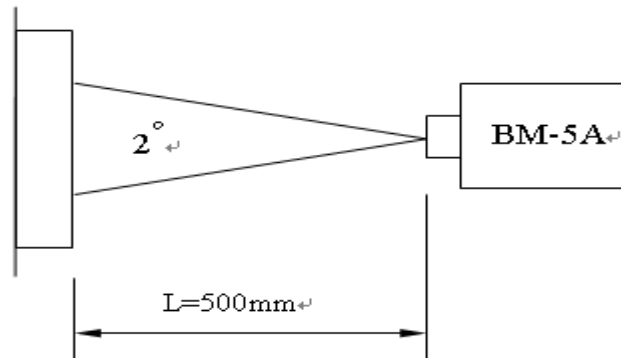

\*2) Definition of contrast ratio : Measure the point-7 as figure 8-1  
 Contrast Ratio (CR)= (White) Luminance of ON / (Black) Luminance of OFF

\*3) Definition of luminance: Measure white luminance on the 5 points as figure8-1  
 $L_{W,AVE} = [Lw(4) + Lw(5) + Lw(7) + Lw(9) + Lw(10)] / 5$

\*4) Definition of Luminance Uniformity:  
 Measure white luminance on the point 4、5、7、9、10 as figure8-1  
 $\Delta L = Lw(\text{Max})_{5\text{points}} \div Lw(\text{Min})_{5\text{points}}$

\*5) Definition of Luminance Uniformity :  
 Measure white luminance on the point 1~13 as figure8-1  
 $\Delta L = Lw(\text{Max})_{13\text{points}} \div Lw(\text{Min})_{13\text{points}}$



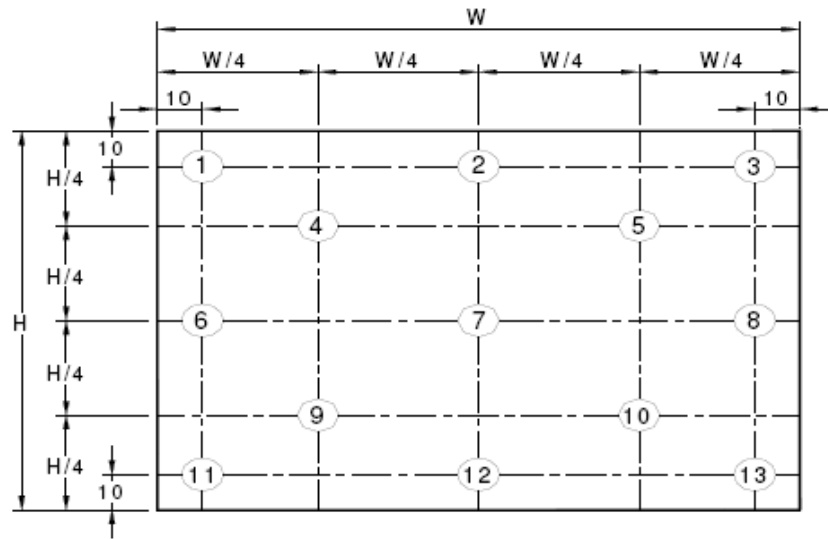

Fig8-1 Measuring point

\*6) Definition of Viewing Angle( $\theta, \psi$ ), refer to Fig8-2 as below : These items are measured by EZ-CONTRAST (ELDIM) in the dark room. (no ambient light).

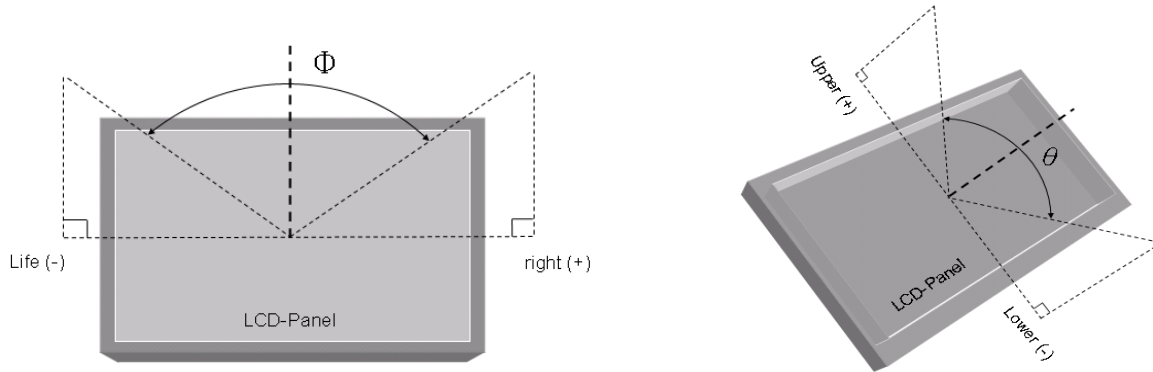

Fig8-2 Definition of Viewing Angle

\*7) Definition of Response Time.(White-Black)

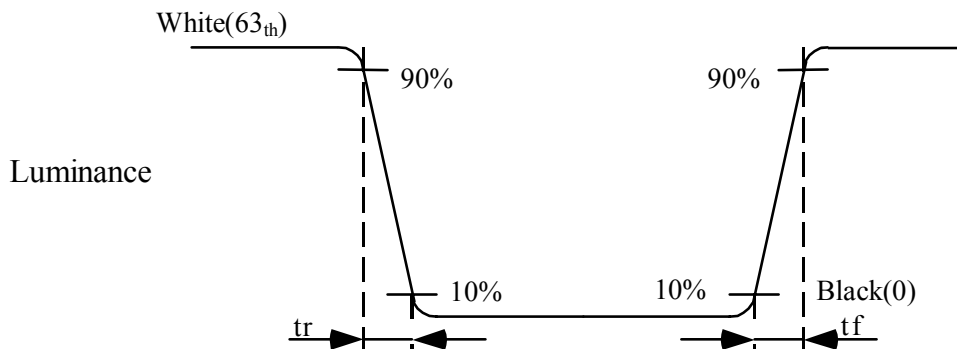

Fig8-3 Definition of Response Time (White-Black)

## 9. RELIABILITY TEST

### 9.1. Temperature and humidity

TEST ITEMS	CONDITIONS	NOTE
High Temperature Operation	50°C , 240Hrs	
High Temperature Storage	60°C , 240Hrs	
High Temperature High Humidity Operation	50°C , 90%RH , 240Hrs	No condensation
Low Temperature Operation	0°C , 240Hrs	
Low Temperature Storage	-20°C , 240Hrs	
Thermal Shock	-20°C (0.5Hr) ~ 60°C(0.5Hr) 200 cycles	

### 9.2. Shock and Vibration:

TEST ITEMS	CONDITIONS
Shock (Non-operation)	<ul style="list-style-type: none"> <li>● Shock level:980m/s<sup>2</sup>(equal to 100G)</li> <li>● Waveform:half sinusoidal wave,6ms.</li> <li>● Number of shocks:one shock input in each direction of three mutually perpendicular axes for a total of three shock inputs.</li> </ul>
Vibration (Non-operation)	<ul style="list-style-type: none"> <li>● Frequency range:8~33.3Hz</li> <li>● Stroke:1.3mm</li> <li>● Vibration:sinusoidal wave,perpendicularaxis(both x, z axis:2Hrs, y axis 4Hrs).</li> <li>● Sweep:2.9G,33.3Hz-400Hz</li> <li>● Cycle:15min</li> </ul>

### 9.3. ESD Test

ITEM	CONDITION	NOTE
ESD	150pF , 330Ω , ±8KV&±15KV air test	*1)
	200pF , 0Ω , ±250V contact test	*2)

NOTE:

\*1) LCD glass and metal bezel

\*2) IF connector pins

### 9.4 Judgment Standard

The Judgment of the above test should be made as follow:

Pass: Normal display image with no obvious non-uniformity and no line defect.Partial transformation of the module parts should be ignored.

Fail: No display image,obvious non-uniform,or line defect.