



Chunghwa Picture Tubes, Ltd.

Product Specification

Date : 070529

TFT LCD
CLAA090JB01CW

ACCEPTED BY : (V0.1)
Tentative

APPROVED BY	CHECKED BY	PREPARED BY
張聖暉	李家銘	紀熙豪

Prepared by :
Product Planning Management Division
Small & Medium TFT Product Business Unit
CHUNGHWA PICTURE TUBES, LTD.

1127 Hopin Rd., Padeh, Taoyuan, Taiwan 334, R.O.C.
TEL: +886-3-3675151 FAX: +886-3-377-3858

Doc.No:	SPEC_CLAA090JB01CW_V0.1_070529	Issue Date:	2007/05/02
---------	--------------------------------	-------------	------------

CONTENTS

1. OVERVIEW	4
2. ABSOLUTE MAXIMUM RATINGS	5
3. ELECTRICAL CHARACTERISTICS	6
3.1 Typical operation conditions	6
3.2 Current consumption.....	7
3.3 Timing characteristics of input signals	7
3.4 Sequence for power on/off and signal on/off	7
3.5 Backlight.....	8
4. INTERFACE CONNECTION	9
4.1 CN1	9
4.2 CN2 (Back Light)	11
5. MECHANICAL DIMENSION	12
5.1 Front Side	12
5.2 Rear Side	12
6. OPTICAL CHARACTERISTICS	13
7. RELIABILITY TEST CONDITIONS	15
7.1 Temperature and Humidity	15
7.2 Shock & Vibration.....	15
7.3 Electrostatic Discharge.....	15
7.4 Judgment standard.....	15

1. OVERVIEW

CLAA090JB01CW is 9" color TFT-LCD (Thin Film Transistor Liquid Crystal Display) module composed of LCD panel, driver ICs and backlight. By applying 640×220 images are displayed on the 9" diagonal screen. General specification are summarized in the following table:

ITEM	SPECIFICATION
Display Area (mm)	202.56(H) × 105.27(V)
Number of Pixels	640 (H)x3(RGB) × 220(V)
Pixel Pitch (mm)	0.1055(H) × 0.4785(V)
Color Pixel Arrangement	RGB vertical stripe
Display Mode	Normally white, TN
Number of Colors	Full color
Optimum Viewing Angle	6 o'clock
Brightness (cd/m ²)	180nit(min)/200nit(typ)
Contrast Ratio	350:1(typ)
Response Time (ms)	30 (typ)
Viewing Angle	120 degree (Horizontal.)
	110 degree (Vertical)
NTSC ratio	45%
Power Consumption	1.5W(typ.)
Module Size (mm)	219.4 (W)x 120.8(H) x 6.6(D)
Module Weight (g)	300 g(typ.)
Backlight Unit	LED
Surface Treatment	Anti-Glare

2. ABSOLUTE MAXIMUM RATINGS

The following are maximum values which, if exceeded, may cause faulty operation or damage to the unit.

ITEM	SYMBOL	MIN.	MAX.	UNIT	NOTE
Power Supply Voltage For LCD	VCC	-0.3	7.0	V	GND=0
	AVDD	-0.3	7	V	AVSS=0
	VGH	-0.3	25	V	GND=0
	VGL	-15	0.3	V	GND=0
Input Voltage	Vi	-0.2	AVDD+0.2	V	Note1
	VI	-0.3	VCC+0.3	V	Note2
Forward Current (per LED)	If		30	mA	
Reverse Voltage (per LED)	VR		5	V	
Pulse forward current (per LED)	I _{fp}		100	mA	Note3

[Note]

Note1 : Analog input voltage VR, VG, VB

Note2 : Logical signal STHL, STHR, OEH, L/R, CPH1~CPH3, STVR, STVL, OEV, CKV, U/D.

Note 3 : **I_{fp} Conditions : Duty 1/10@10ms**

3. ELECTRICAL CHARACTERISTICS

3.1 Typical operation conditions (GND = Avss = 0V)

Ta=25°C

ITEM	SYMBOL	MIN	TYP	MAX	UNIT	NOTE
Power Supply Voltage	VCC	3	5	5.5	V	
	AVDD	4.5	5	5.5	V	
	VGH	17	18	19	V	
	VGL	-7	-6	-5	V	
Signal Amplitude (VR, VG, VB)	ViA	0.4	-	AVDD-0.4	V	Note1
	ViAC	-	4	-	V	Note1
	ViDC	-	AVDD/2	-	V	Note1
VCOM	VCAC	4	5.6	6.5	Vp-p	Note1,2
	VCDC	1.8	2.0	2.2	V	Note1,3
Input Signal Voltage	VIH	0.7VCC	-	VCC	V	Note4
	VIL	0	-	0.3VCC	V	

[Note]

Note1 : Please refer to Fig.6

Note2 : Brightness level is adjusted by varying this amplitude V_{CAC}

Note3 : Please adjust V_{CDC} to make the flicker level be minimum.

Note4 : logical signal STHL,STHR,OEHL,L/R,CPH1~CPH3,STVR,STVL,OEVL,CKV,U/D

3.2 Current consumption (GND = Avss = 0V)

ITEM	SYMBOL	CONDITION	MIN	TYP	MAX	UNIT	NOTE
Drive Current	IGH	VGH = 18V	-	0.45	1	mA	
	IGL	VGL = -6V	-	0.12	1	mA	
	ICC	VCC = 5V	-	2.5	4.5	mA	
	IDD	AVDD = 5V	-	9	24	mA	

3.3 Timing characteristics of input signals

CHARACTERISTICS	SYMBOL	MIN	TYP	MAX	UNIT	NOTE
1 Field scanning period	T_{IV}	-	262.5	-	H	
1 Line scanning period	T_{IH}	-	66.52	-	μ s	
Source driver operating frequency	F_{OP}	-	11.5	-	MHz	
CLK pulse width	T_{CW}	100	104	108	ns	
CLK pulse high period	T_{CWH}	40	50	60	ns	
CLK pulse low period	T_{CWL}	40	50	60	ns	
CLK pulse delay	TC12 TC23 TC31	32.5	35.1	38.2	ns	CPH1~CPH3
STH start pulse width	T_{STH}	30	85.3	-	ns	STHR,STHL
STH start pulse setup time	T_{SUH}	20	55.7	-	ns	STHR,STHL
STH start pulse hold time	T_{HDH}	10	28.8	-	ns	STHR,STHL
OEH output enable pulse width	T_{OEH}	1.5	2	2.5	μ s	OEH
Sample and hold disable time OEH&STH	$T_{OEH-STH}$	-	8.2	-	μ s	OEH-STH
CLKV pulse width	T_{CKVW}	5	63.5	-	μ s	CKV
CLKV pulse high period	T_{CKVH}	2.5	16.5	-	μ s	CKV
CLKV pulse low period	T_{CKVL}	2.5	47	-	μ s	CKV
STV start pulse width	T_{STV}	5	63.5	-	μ s	STVR, STVL
STV start pulse setup time	T_{SUV}	2.5	48	-	μ s	STVR, STVL
STV start pulse hold time	T_{HDV}	2.5	15.5	-	μ s	STVR,STVL

[Note1] 1. High level of source driver and gate driver logic signal are 70%

2. Low level of source driver and gate driver logic signal are 30%

[Note2] Please refer to Fig. 4 and Fig. 5

3.4 Sequence for power on/off and signal on/off

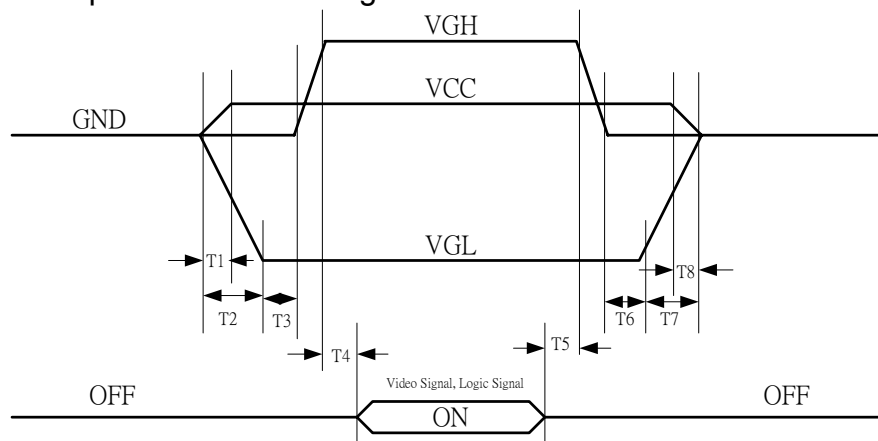

$$0 < T1 < T2 \leq 20\text{ms}$$

$$T3 \leq 10\text{ms}$$

$$T4 \leq 10\text{ms}$$

$$T5 \leq 10\text{ms}$$

$$T6 \leq 10\text{ms}$$

$$T8 < T7 \leq 10\text{ms}$$

3.5 Backlight

Electrical Characteristics

Ta=25°C

ITEM	SYMBOL	MIN	TYP	MAX	UNIT	NOTE
LED current	IL	--	140		mA	Note 1
LED voltage	VL	9.0	9.9	10.8	V	Note 1
Power consumption	WL	--	1.386	--	W	Note 1

[Note1]LED B/L circuit as below,A : Anode,K : Cathode

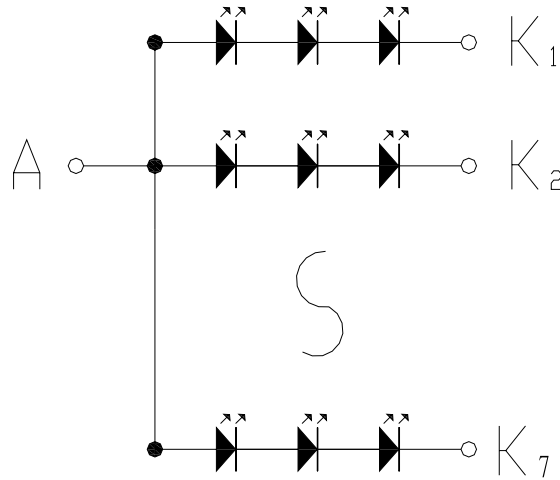

4. INTERFACE CONNECTION

4.1 CN1

Pin No.	SYMBOL	I/O	FUNCTION	NOTE
1	GND	-	Digital ground pin for Gate driver	
2	VCC		Supply power for gate digital circuit	
3	VGL		Gate driver negative voltage	
4	VGH		Gate driver positive voltage	
5	STVD	I/O	Gate scanning start signal	Note 1
6	STVU	I/O	Gate scanning start signal	Note 1
7	CKV		Gate driver scanning clock pulse	
8	U/D		Up/Down scanning change	Note 1
9	OEV		Gate driver output enable	
10	VCOM		Voltage applied to color filter substrate	
11	VCOM		Voltage applied to color filter substrate	
12	L/R		Left / Right scanning change	Note 2
13	MOD		Sampling mode change (H: Simultaneous, L: Sequential)	Note 3
14	OEH		Source driver output enable	
15	STHL	I/O	Source scanning start signal	Note 2
16	STHR	I/O	Source scanning start signal	Note 2
17	CPH3		Source driver clock input 3	
18	CPH2		Source driver clock input 2	
19	CHP1		Source driver clock input 1	
20	VCC		Supply power for source digital circuit	
21	GND	-	Digital ground pin for source driver	
22	VR		Red video signal	
23	VG		Green video signal	
24	VB		Blue video signal	
25	AVDD		Supply power for analog circuit	
26	AVSS	-	Analog ground pin	

Note1 : The function of STVR and STVL is changed as follows by the U/D terminal (up/down scanning)

U/D	STVR	STVL
H(VCC)	Signal Input	Signal Output
L(GND)	Signal Output	Signal Input

Note2 : The function of STHR and STHL is changed as follows by the L/R terminal(right/left scanning)

L/R	STHL	STHR
H(VCC)	Signal Input	Signal Output
L(GND)	Signal Output	Signal Input

Note3 : MOD=H:Simultaneous sampling (Set CPH2 and CPH3 to GND)

MOD=L:Sequential sampling

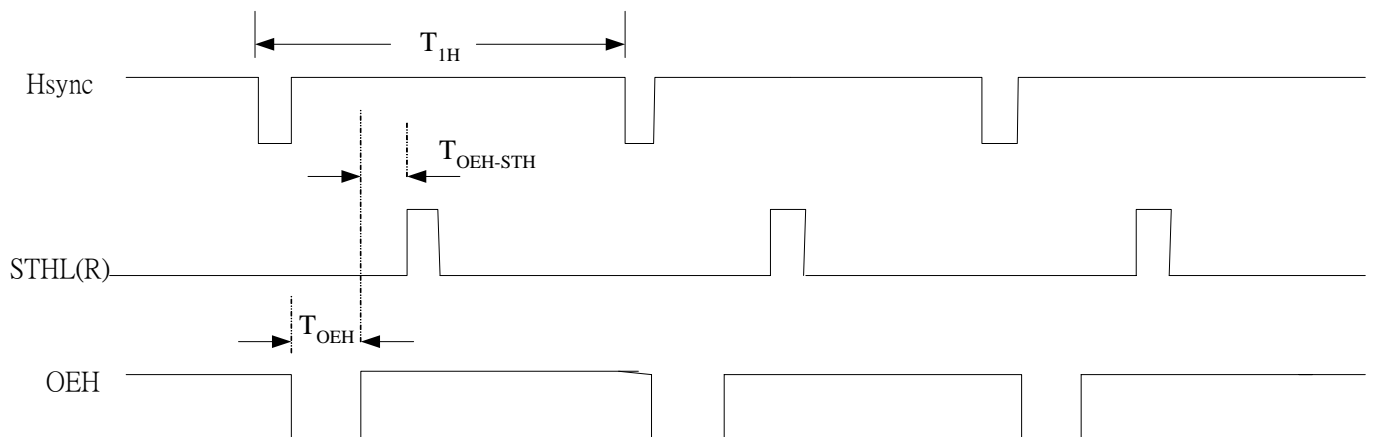

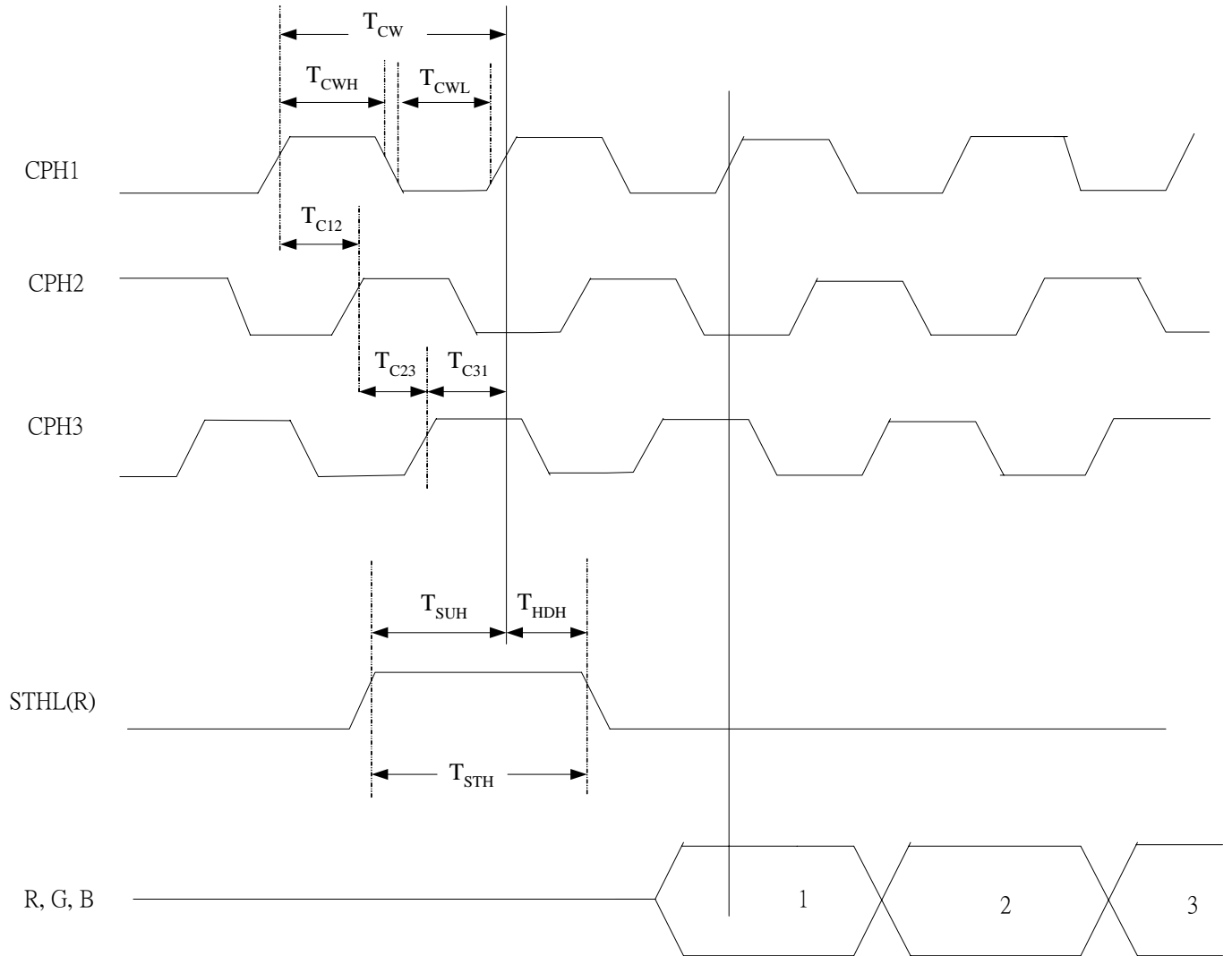

Fig.4 Horizontal Timing sequence

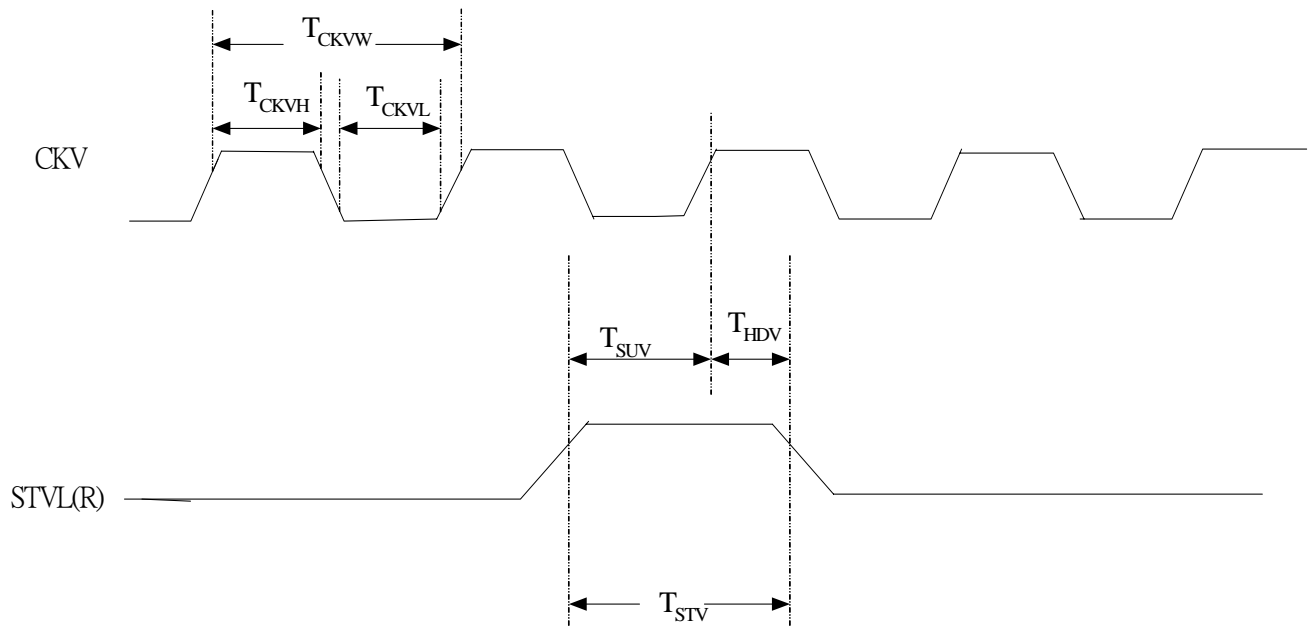

Fig.5 Vertical Timing sequence

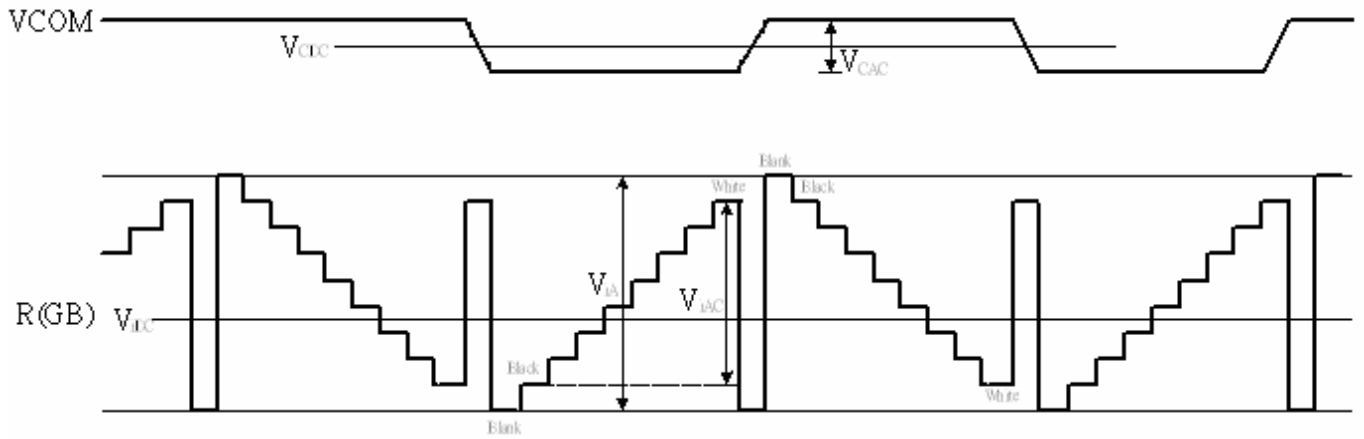

Fig.6 VCM-RGB

4.2 CN2 (Back Light)

Backlight-side connector: BHSR-02VS-1 (JST made)

Pin No.	SYMBOL	FUNCTION
1	CTH	VBLH (High voltage)
2	CTL	VBLL (Low voltage)

[Note] : VBLH-VBLL=VL

6. OPTICAL CHARACTERISTICS

Ta = 25°C,
VCC=3.3V

ITEM	SYMBOL	CONDITION	MIN.	TYP.	MAX.	UNIT	
Contrast	CR	*1)	300	350	--	--	
Luminance (CEN)	L	I _L = 20 mA	180	200	--	cd/m ²	
Luminance Uniformity	ΔL	*2)	70	80	--	%	
Color saturation			40	45		%	
Response Time	T	*4)	--	30	35	ms	
View angle	Horizontal	ψ*3)	CR ≥ 10	110	120		°
	Vertical	θ*3)		90	110		°
Color Coordinate	White	x y	θ = φ = 0°	(0.283) (0.299)	(0.313) (0.329)	(0.343) (0.359)	
	Red	x y	θ = φ = 0°		TBD		
	Green	x y	θ = φ = 0°		TBD		
	Blue	x y	θ = φ = 0°		TBD		

[Note]

● These items are measured by BM-5A (TOPCON) or CA-1000(MINOLTA) in the dark room. (no ambient light).

*1) Definition of contrast ratio :

Measure contrast ratio on the #5 points (refer to figure1) .

Contrast ratio is calculated with the following formula :

Contrast Ratio (CR)= (White) Luminance of ON ÷ (Black) Luminance of OFF

*2) Definition of Luminance Uniformity :

Measure maximum luminance(L(MAX))and minimum luminance (L(MIN))on the 9 points as figure 1(#1~#9 poin).Luminance Uniformity is calculated with the following formula :

$$\Delta L = (L(MIN) \div L (MAX)) \times 100$$

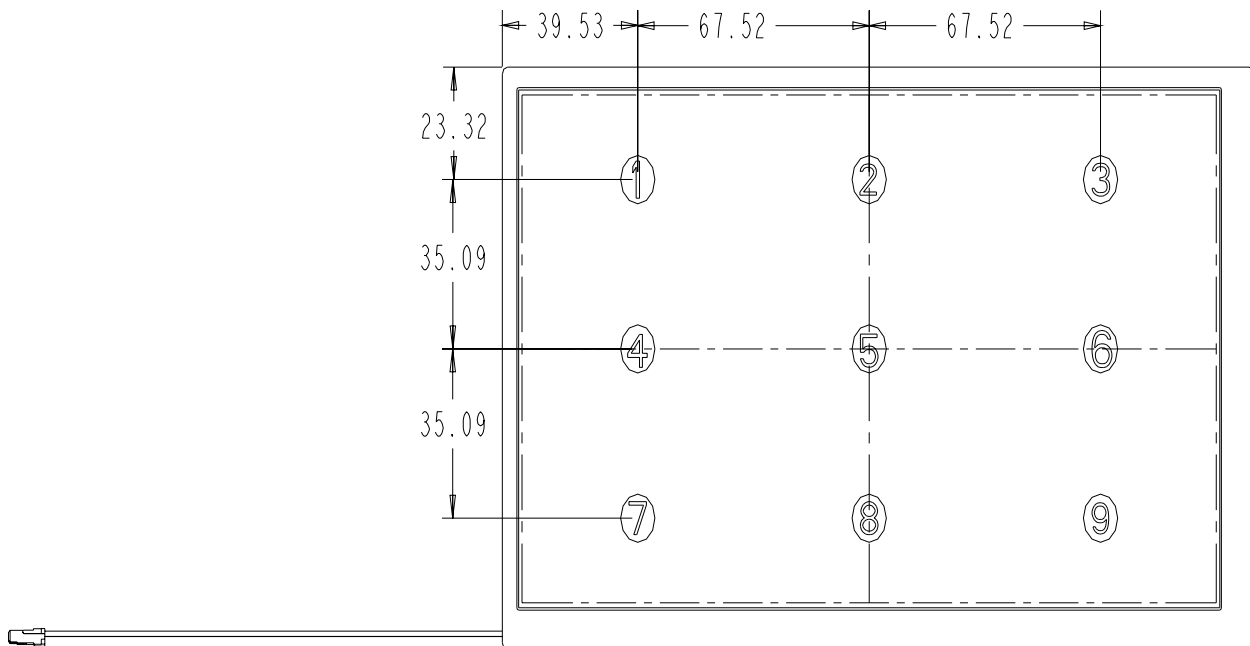

Fig.1 Measuring point

*3) Definition of Viewing Angle(θ, ψ), refer to Fig.2 as below :

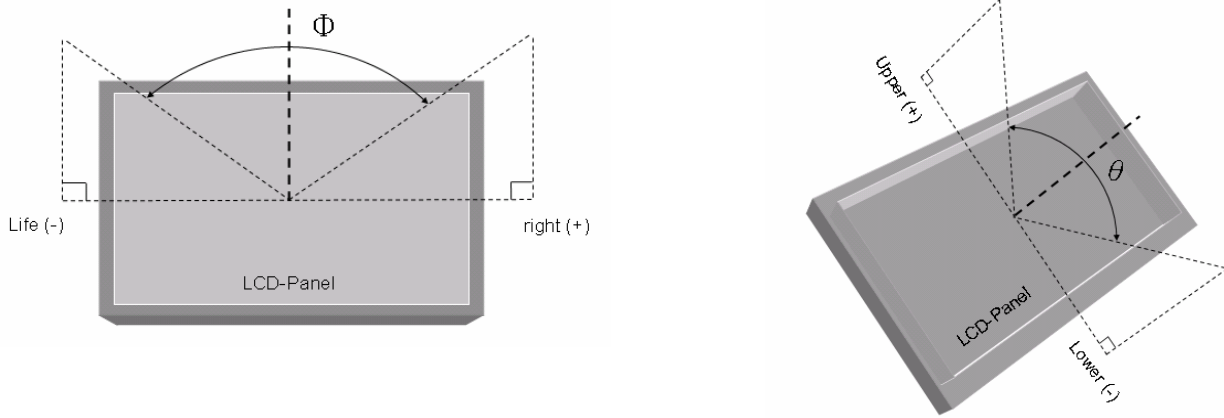

Fig.2 Definition of Viewing Angle

*4) Definition of Response Time.

The response time is defined as the time interval between the 10% and 90% amplitudes. Refer to figure 3 as below.

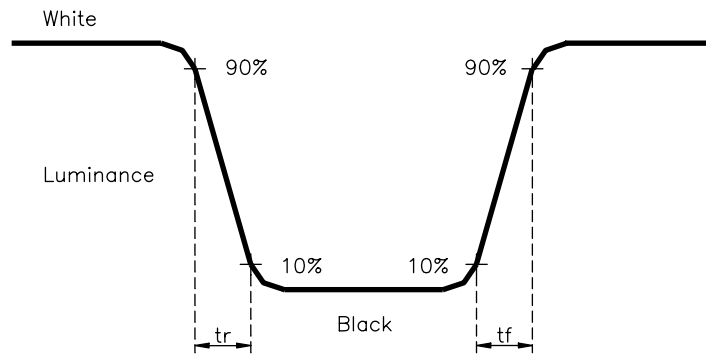

Fig.3 Definition of Response Time

7. RELIABILITY TEST CONDITIONS

7.1 Temperature and Humidity

TEST ITEMS	CONDITIONS
High Temperature Operation	85°C; 240hrs
High Temperature High Humidity Operation	60°C; 90%RH; 240hrs (No condensation)
High Temperature Storage	95°C; 240hrs
Low Temperature Operation	-30°C; 240hrs (Backlight unit always turn on)
Low Temperature Storage	-40°C; 240hrs
Thermal Shock (No operation)	Between -30°C (0.5hr) and 85°C (0.5hr); 200 Cycles

7.2 Shock & Vibration

ITEMS	CONDITIONS
Shock (Non-Operation)	980m/S ² (equal to 100G), 6ms, (1/2 Sine wave), Each axis X,Y,Z.
Vibration (Non-Operation)	Frequency range:8~33.3Hz Stoke : 1.3 mm Vibration: sinusoidal wave, perpendicular axis(both x,z axis: 2Hrs , y axis: 4Hrs). Sweep: 2.9G, 33.3~400Hz Cycle: 15 min

7.3 Electrostatic Discharge

TEST ITEM	CONDITIONS	Note
ESD	150pF , 330Ω , ±8kV&±15kV air & contact test	(1)
	200pF , 0Ω , ±200V contact test	(2)

[NOTE] Measure point : (1) LCD glass and metal bezel
(2) IF connector pins

7.4 Judgment standard

The judgment of the above test should be made as follow:

Pass: Normal display image with no obvious non-uniformity and no line defect.
(Partial transformation of the module parts should be ignored.)

Fail: No display image, obvious non-uniformity, or line defects.