



Chunghwa Picture Tubes, Ltd.

Product Specification

To :
Date : 071129

TFT LCD

CLAA080MB0GCW

ACCEPTED BY : (V0.7)

APPROVED BY	CHECKED BY	PREPARED BY
張聖暉	李家銘	莊志升

Prepared by :
Product Planning Management Division
Small & Medium TFT Product Business Unit
CHUNGHWA PICTURE TUBES, LTD.

1127 Hopin Rd., Padeh, Taoyuan, Taiwan 334, R.O.C.
TEL: +886-3-3675151 FAX: +886-3-377-3858

Doc.No:	SPEC_CLAA080MB0GCW_V0.7_071129	Issue Date:	2007/11/26
---------	--------------------------------	-------------	------------

CONTENTS

1. OVERVIEW	4
2. ABSOLUTE MAXIMUM RATINGS	5
3.ELECTRICAL CHARACTERISTICS	6
3.1TFT LCD Power Voltage.....	6
3.2 TFT-LCD current consumption	6
3.3 Power、 Signal sequence.....	7
4. INTERFACE CONNECTION.....	8
5. INPUT SIGNAL((TTL).....	10
5.1 Timing Specification.....	10
5.2 Horizontal Timing Chart.....	10
5.3 Vertical Timing Chart	11
5.4 Color Data Assignment.....	12
6. BLOCK DIAGRAM	13
7. MECHANICAL DIMENSION.....	14
7.1 Front Side	14
7.2 Rear Side.....	15
8. OPTICAL CHARACTERISTICS	16
9. RELIABILITY TEST	18
9.1. Temperature and humidity	18
9.2. Shock and Vibration.....	18
9.3. Judgment standard	18

1. OVERVIEW

CLAA080MB0GCW is 20.32cm(8") color TFT-LCD(Thin Film Transistor Liquid Crystal Display)module composed of LCD panel,driver ICs,power circuit,and backlight.

The 8.0" screen produces a high resolution image that is composed of 800×600 pixel elements in a stripe arrangement.Display 262K colors by 6 Bit R.G.B signal input.Inverter for backlight and drive board for panel are not included in this module.Use 3.3 voltage to drive the power of LCD system.

General specifications are summarized in the following table:

ITEM	SPECIFICATION
Panel Size	8 inch(panel diagonal)
Display Area (mm)	162.0(H)×121.5(W)
Number of Pixels	800(H) x 3(RGB) x 600(V)
Pixel Pitch (mm)	0.2025(H)×0.2025(V)
Color Pixel Arrangement	RGB vertical stripe
Display Mode	Normally white
Number of colors	262,144
Brightness(cd/m ²)	250 (typ.)
NTSC ratio	50 %
Response Time (Tr+Tf)	25 ms
Outline Dimension(in mm)	183(W) x 141(H) x 6.3(D) (TYP)
Viewing Angle(BL on,CR≥10)	140 degree(H) · 120 degree(V)
Power consumption (W)	2.5
BL unit	LED
Electrical Interface(data)	TTL
Viewing Direction	6 o'clock
Weight (g)	200 (typ.)
Surface Treatment	Anti-Glare · Hardness:3H

2. ABSOLUTE MAXIMUM RATINGS

Item	Symbol	Min.	Max.	Unit	Note
Power Supply Voltage	V _{cc}	-0.3	4.0	V	
Signal Input Voltage	R0~ R5 / G0~G5 B0~B5 / DCLK	-0.3	V _{cc} + 0.3	V	
Static Electricity	VESDc	-200	200	V	【Note2】
	VESDm	-15K	15K	V	
ICC Rush Current	IRUSH	-	1	A	【Note3】
Operation temperature	T _{op}	-30	70	°C	【Note1】
Storage temperature	T _{stg}	-40	80	°C	【Note1】
Forward Current (per LED)	I _f		30	mA	
Reverse Voltage (per LED)	VR		5	V	
Pulse forward current (per LED)	I _{fp}		100	mA	【Note4】

[Note]

*1) If users use the product out off the environment operation range (temperature and humidity),it will concern for visual quality.

*2)Test Condition: IEC 61000-4-2 ,

VESDc : Contact discharge to input connector

VESDm : Contact discharge to module

*3) The Input pulse-current measurement system as below :

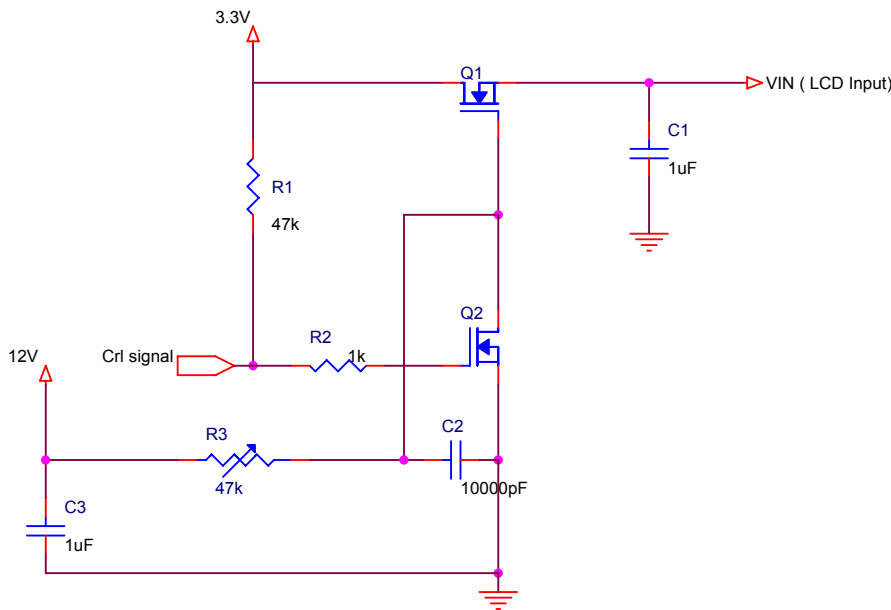

Control signal:High(+3.3V)→Low(GND)

Supply Voltage of rising time should be from R3 and C2 tune to 550 us.

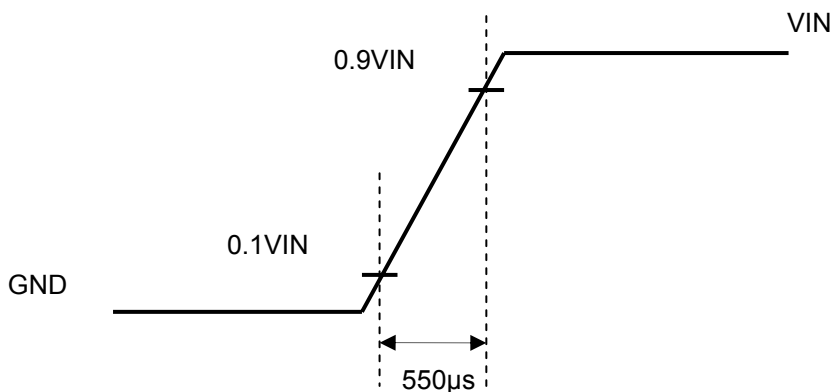

*4) I_{fp} Conditions : Pulse Width ≤ 10msec and Duty ≤ 1/10 ◦

3.ELECTRICAL CHARACTERISTICS

3.1TFT LCD Power Voltage

Ta=25°C

Item	Symbol	Min.	Typ	Max.	Unit	Note
Power Supply Voltage For LCD	VCC	3.0	3.3	3.6	V	[Note1]
Logic Input Voltage	VIH	0.7VCC		VCC	V	
	VIL	0		0.3VCC	V	

[Note1]VCC –dip codition:

- 1) When $2.7\text{ V} \leq VCC < 3.0\text{V}$, $td \leq 10\text{ms}$.
- 2) $VCC > 3.0\text{V}$, VCC-dip condition should be same as VCC-turn-on condition.

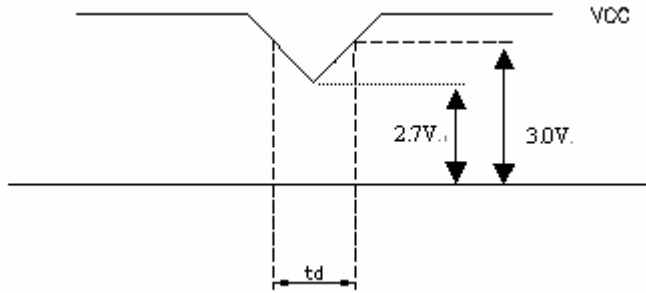

3.2 TFT-LCD current consumption

Item	Symbol	Min.	Typ	Max.	Unit	Note
LCD Power Current	ICC	--	150	250	mA	【Note1】

[Note1]

Vcc = 3.3V · Frequency = 60Hz

Typical: Under 64 gray pattern

Maximum: Under black pattern

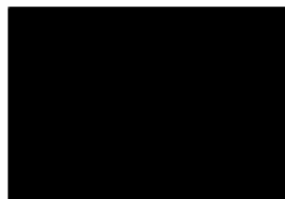

·· (a)64·Gray·Pattern······ (b)Black·Pattern···↵

3.3 Power 、 Signal sequence

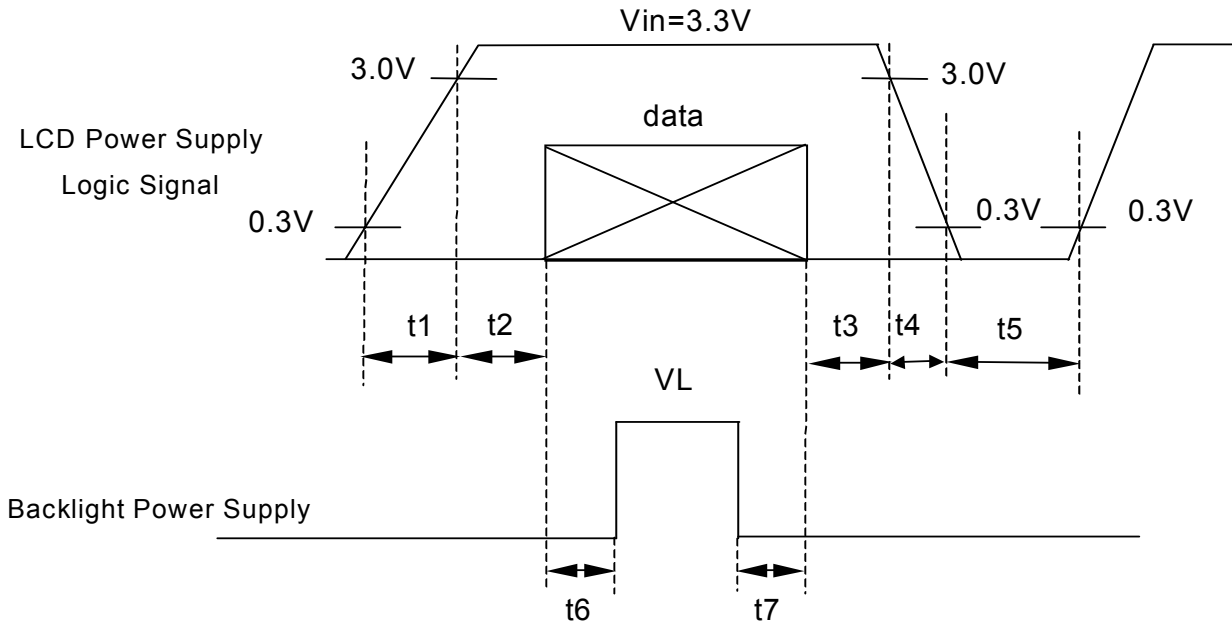

Data: RGB DATA, DCLK, DENA
 $t_1 \leq 10ms$ $1 \text{ sec} \leq t_5$
 $50ms \leq t_2$ $200ms \leq t_6$
 $0 < t_3 \leq 50ms$ $200ms \leq t_7$
 $0 < t_4 \leq 10ms$

3.4 Backlight unit

ITEM	SYMBOL	MIN.	TYP.	MAX.	UNIT	Note
LED current	I_L	--	160	--	mA	Note 1、2
LED voltage	V_L	9.0	9.6	10.65	V	Note 1、2
Power consumption	W_L	--	1.536	--	W	Note 1、2

($T_a=25^\circ C$)

Note 1 : The LED driving condition is defined for each LED module. (3 LED Serial)

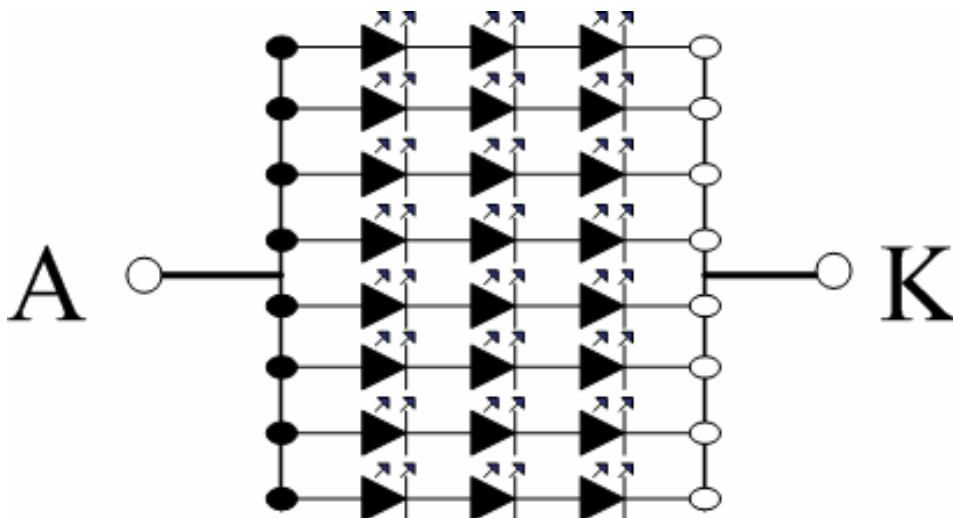

A : ANOD (+) K : CATHOD (-)

Note 2 : We suggest using the constant current control, $I_L=160mA$, to avoid the leakage light and brightness quality issue.

4. INTERFACE CONNECTION

Pin NO.	SYMBOL	DESCRIPTION
1	VCC	Power Supply
2	VCC	Power Supply
3	GND	Power Ground
4	GND	Power Ground
5	CLKH	Source Clock
6	GND	Power Ground
7	DIO1	Start pulse of source
8	SHL	Right or Left Shift Control
9	D00	Red Data(LSB)
10	D01	Red Data
11	D02	Red Data
12	D03	Red Data
13	D04	Red Data
14	D05	Red Data(MSB)
15	GND	Power Ground
16	D10	Green Data(LSB)
17	D11	Green Data
18	D12	Green Data
19	D13	Green Data
20	D14	Green Data
21	D15	Green Data(MSB)
22	GND	Power Ground
23	D20	Blue Data(LSB)
24	D21	Blue Data
25	D22	Blue Data
26	D23	Blue Data
27	D24	Blue Data
28	D25	Blue Data(MSB)
29	GND	Power Ground
30	LD	Latch Pulse
31	REV	Reverse Data
32	POL	Polarity
33	DIO2	Start Pulse of source
34	OEV	OE Enable
35	U/D	Up or Down Shift Control
36	GND	Power Ground
37	CLKV	Gate Clock
38	GND	Power Ground
39	STVU	Start Pulse of Gate
40	STVD	Start Pulse of Gate

Remarks :

- 1) GND Pin had been connected to “ground”, should not be “ Non-Connect ”.
- 2) SHL : Select left or right

SHL	DIO1	DIO2	SHIFT
1	Input	Output	Right
0	Output	Input	Left

- 3) UD : Shift up or down control

UD	STVD	STVU	SHIFT
1	Input	Output	UP
0	Output	Input	Down

5. INPUT SIGNAL((TTL)

5.1 Timing Specification

✚ Horizontal Timing spec :

ITEM	SYMBOL	SPECIFICATION			UNIT
		Min	Typ	Max	
CLKH Frequency	1/Tcph	32	38.28	43	MHz
CLKH Pulse Width	Tcw	--	26	--	ns
Data Set-up Time	Tsu	4	--	--	ns
Data Hold Time	Thd	2	--	--	ns
Propagation Delay of DIO2/1	Tphl	6	10	15	ns
Time That The Last Data to LD	Tld	1	--	--	Tcph
Pulse Width of LD	Twld	2	--	--	Tcph
Time That LD to DIO1/2	Tlds	5	--	--	Tcph
POL Set-up Time	Tpsu	6	--	--	ns
POL Hold Time	Tphd	6	--	--	ns

✚ Vertical Timing spec :

ITEM	SYMBOL	SPECIFICATION			UNIT
		Min	Typ	Max	
CLKV Frequency	1/Tcpv	--	37.6	41.0	KHz
CLKV Pulse Width	Tcpvh	24.4	26.5	--	μs
STVD/STVU Set-up Time	Tsu	700	--	--	ns
STVD/STVU Hold Time	Thd	700	--	--	ns
Output Enabled (OE) pulse width	Twoe	1	--	--	us

5.2 Horizontal Timing Chart

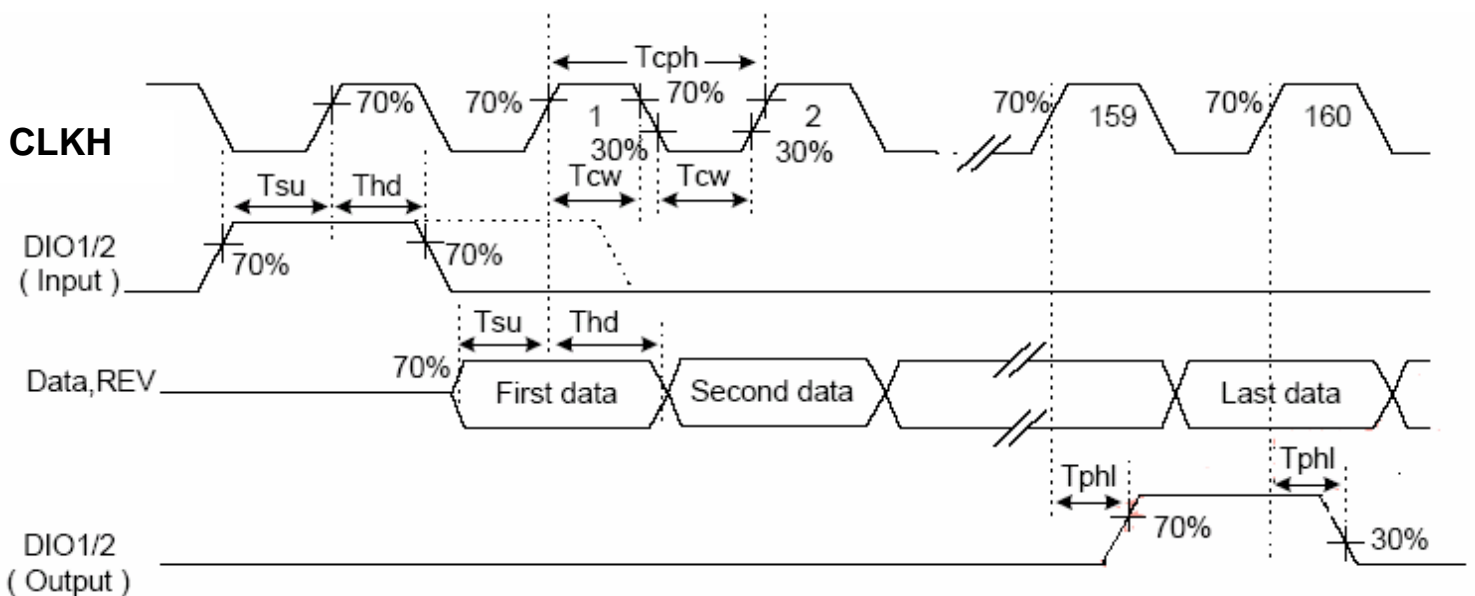

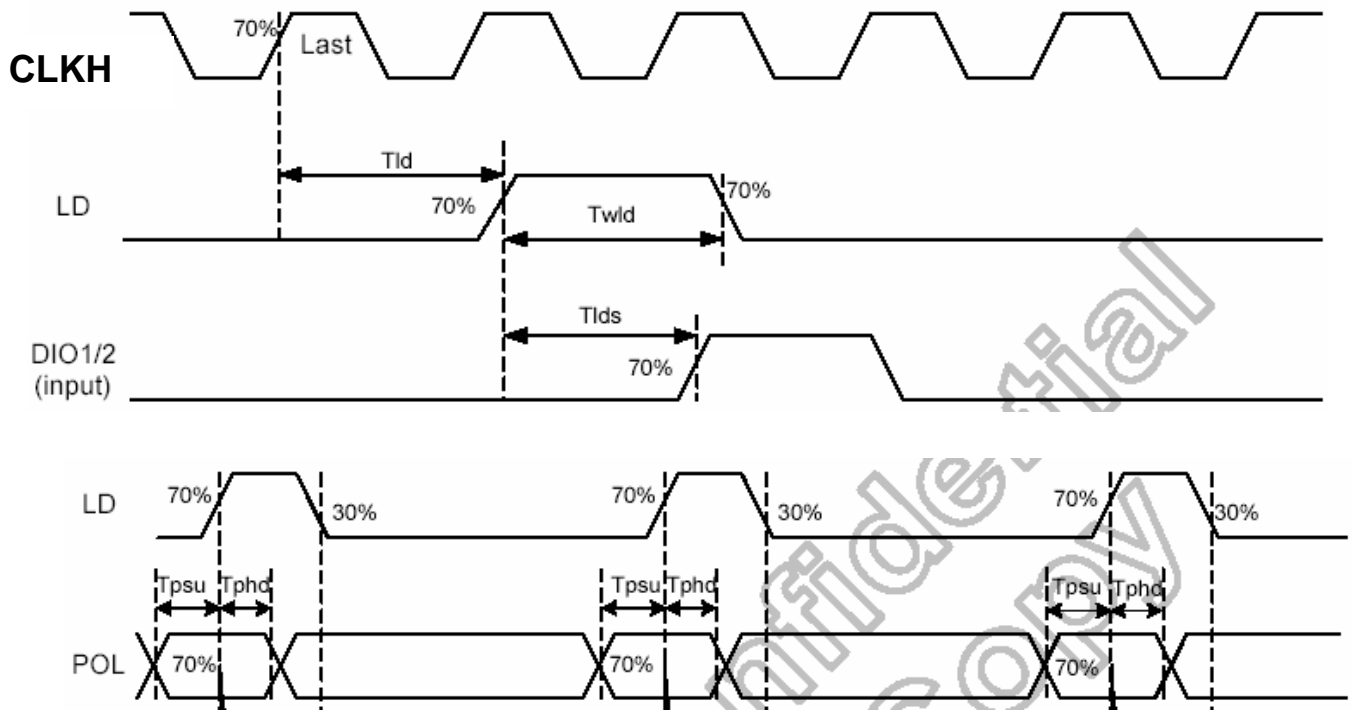

5.3 Vertical Timing Chart

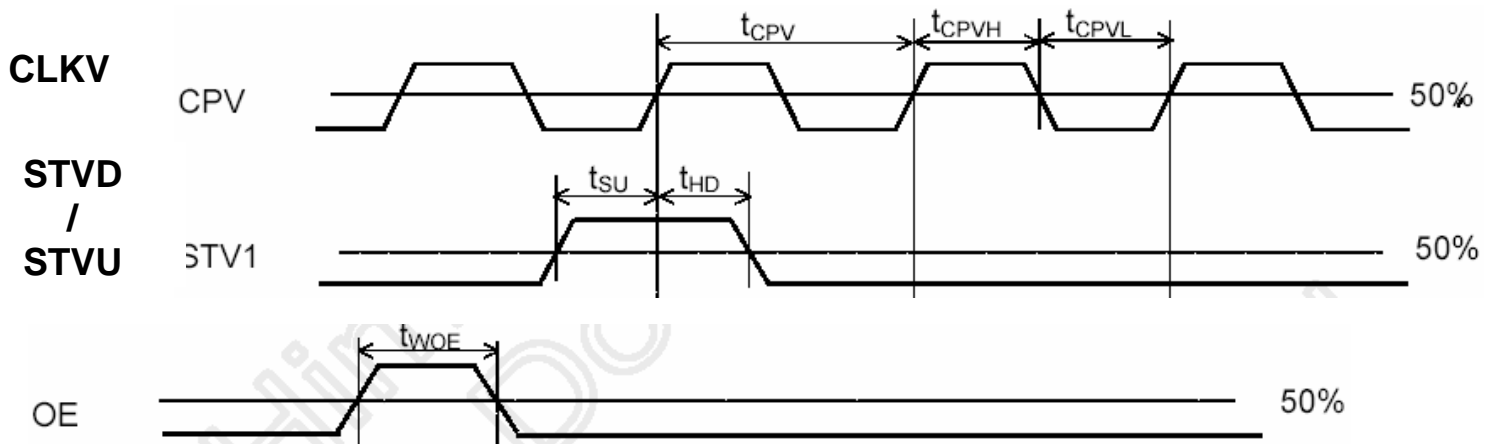

5.4 Color Data Assignment

COLOR	INPUT DATA	R DATA						G DATA						B DATA					
		R5	R4	R3	R2	R1	R0	G5	G4	G3	G2	G1	G0	B5	B4	B3	B2	B1	B0
		MSB					LSB	MSB					LSB	MSB					LSB
BASIC COLOR	BLACK	0	0	0	0	0	0	0	0	0	0	0	0	0	0	0	0	0	0
	RED(63)	1	1	1	1	1	1	0	0	0	0	0	0	0	0	0	0	0	0
	GREEN(63)	0	0	0	0	0	0	1	1	1	1	1	1	0	0	0	0	0	0
	BLUE(63)	0	0	0	0	0	0	0	0	0	0	0	0	1	1	1	1	1	1
	CYAN	0	0	0	0	0	0	1	1	1	1	1	1	1	1	1	1	1	1
	MAGENTA	1	1	1	1	1	1	0	0	0	0	0	0	1	1	1	1	1	1
	YELLOW	1	1	1	1	1	1	1	1	1	1	1	1	0	0	0	0	0	0
	WHITE	1	1	1	1	1	1	1	1	1	1	1	1	1	1	1	1	1	1
RED	RED(0)	0	0	0	0	0	0	0	0	0	0	0	0	0	0	0	0	0	0
	RED(1)	0	0	0	0	0	1	0	0	0	0	0	0	0	0	0	0	0	0
	RED(2)	0	0	0	0	1	0	0	0	0	0	0	0	0	0	0	0	0	0
	RED(62)	1	1	1	1	1	0	0	0	0	0	0	0	0	0	0	0	0	0
	RED(63)	1	1	1	1	1	1	0	0	0	0	0	0	0	0	0	0	0	0
GREEN	GREEN(0)	0	0	0	0	0	0	0	0	0	0	0	0	0	0	0	0	0	0
	GREEN(1)	0	0	0	0	0	0	0	0	0	0	0	1	0	0	0	0	0	0
	GREEN(2)	0	0	0	0	0	0	0	0	0	0	1	0	0	0	0	0	0	0
	GREEN(62)	0	0	0	0	0	0	1	1	1	1	1	0	0	0	0	0	0	0
	GREEN(63)	0	0	0	0	0	0	1	1	1	1	1	1	0	0	0	0	0	0
BLUE	BLUE(0)	0	0	0	0	0	0	0	0	0	0	0	0	0	0	0	0	0	0
	BLUE(1)	0	0	0	0	0	0	0	0	0	0	0	0	0	0	0	0	0	1
	BLUE(2)	0	0	0	0	0	0	0	0	0	0	0	0	0	0	0	0	1	0
	BLUE(62)	0	0	0	0	0	0	0	0	0	0	0	0	1	1	1	1	1	0
	BLUE(63)	0	0	0	0	0	0	0	0	0	0	0	0	1	1	1	1	1	1

[Note]

(1) Definition of Gray Scale

color(n) : n is series of Gray Scale. The more n value is, the bright Gray Scale.

(2)Data:1-High,0-Low

6. BLOCK DIAGRAM

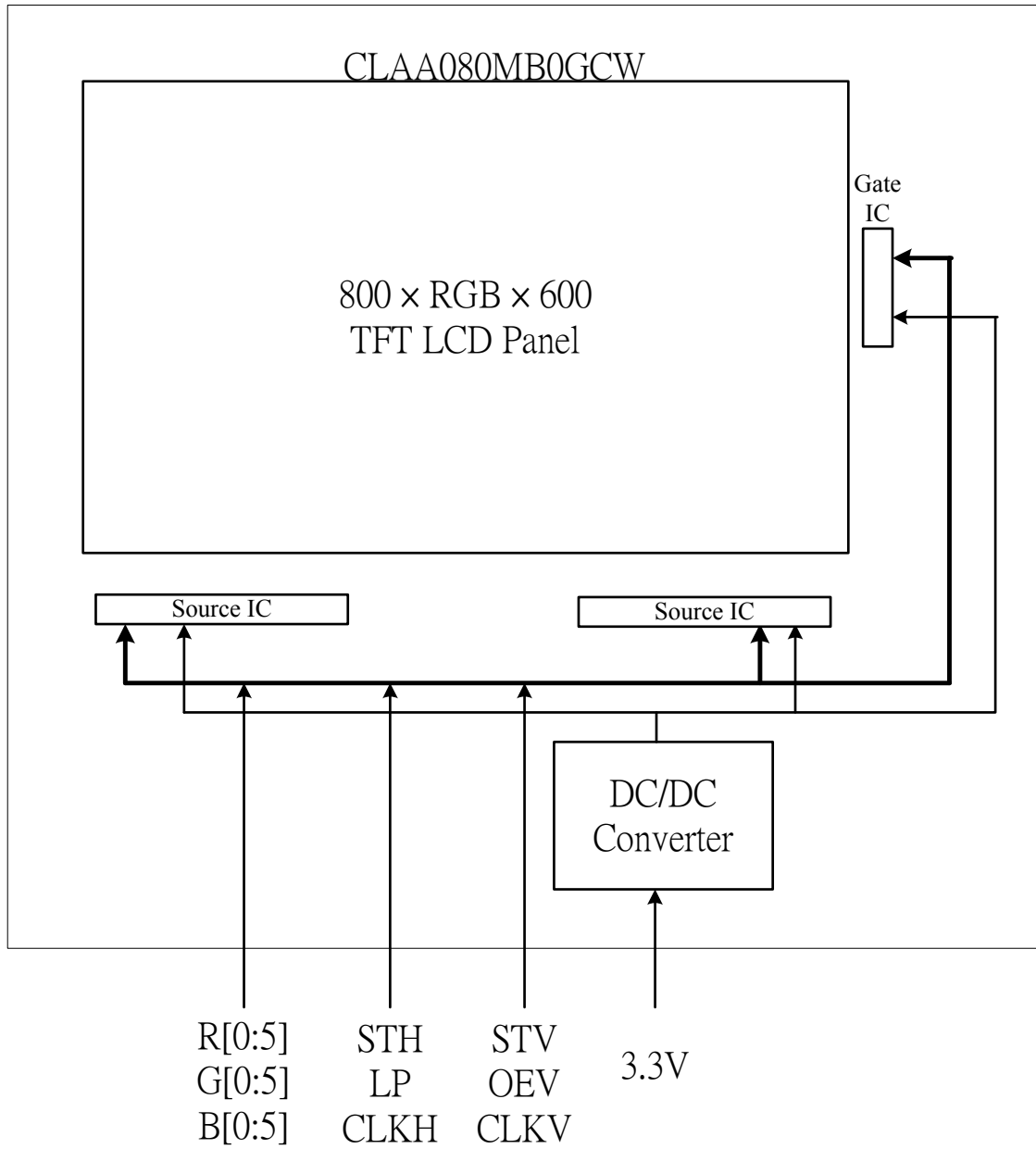

7. MECHANICAL DIMENSION

7.1 Front Side

[Unit : mm]

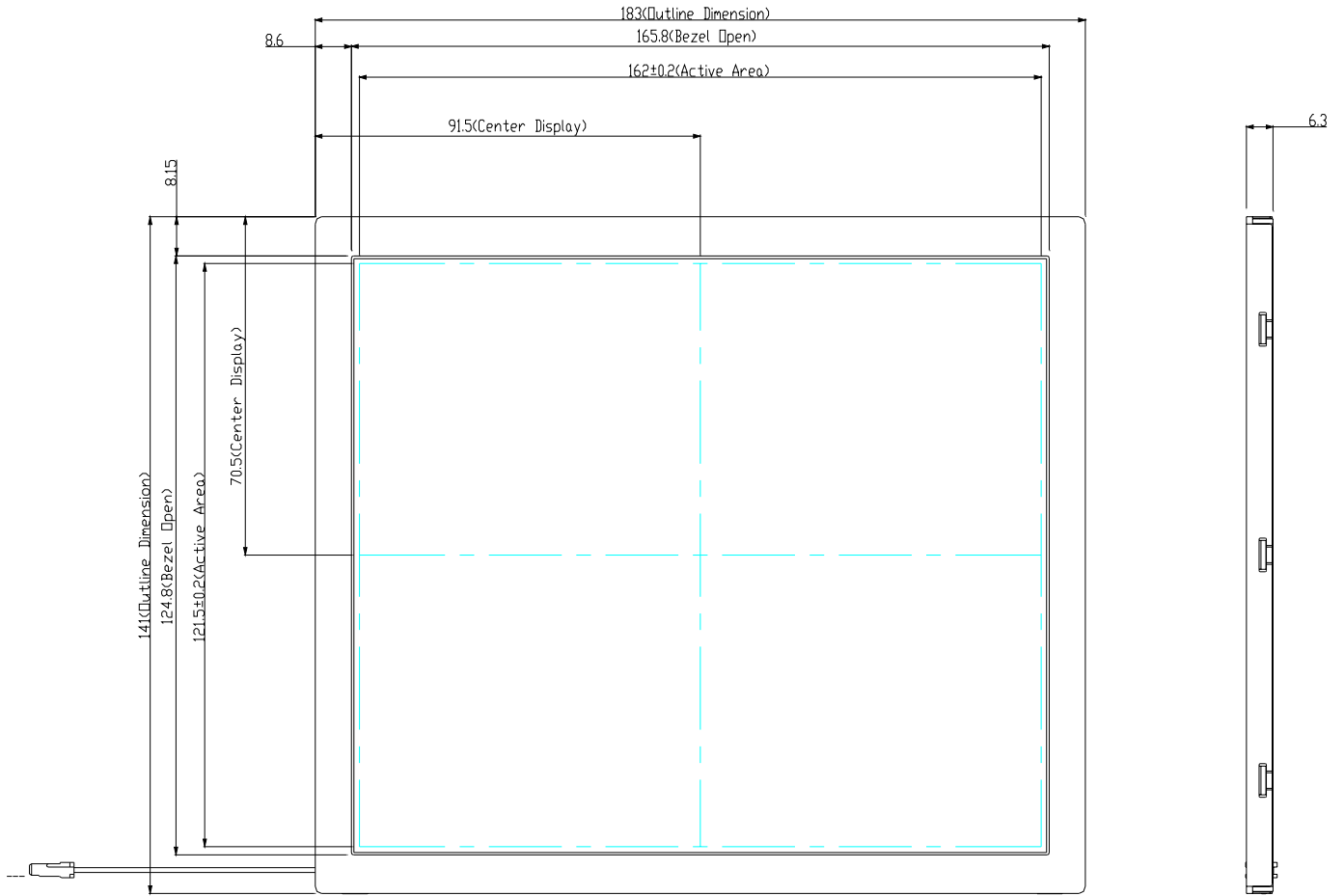

**A:LED(+)
BLACK**

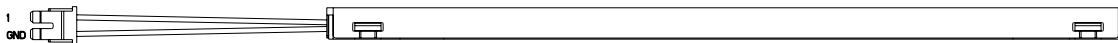

**K:LED(-)
WHITE**

7.2 Rear Side

[Unit : mm]

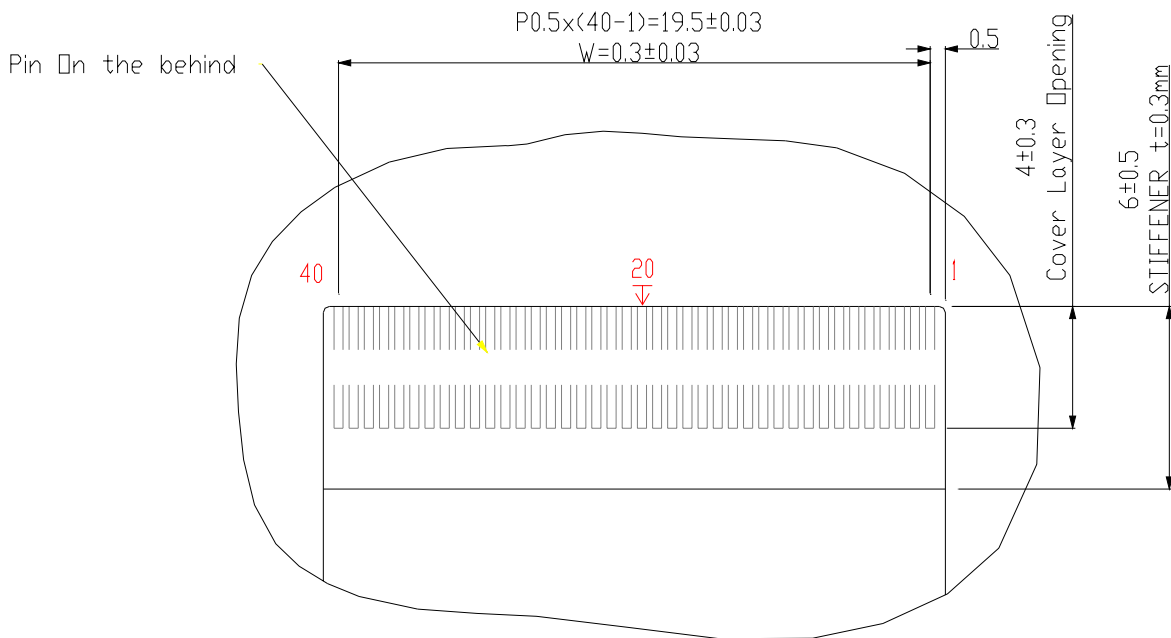
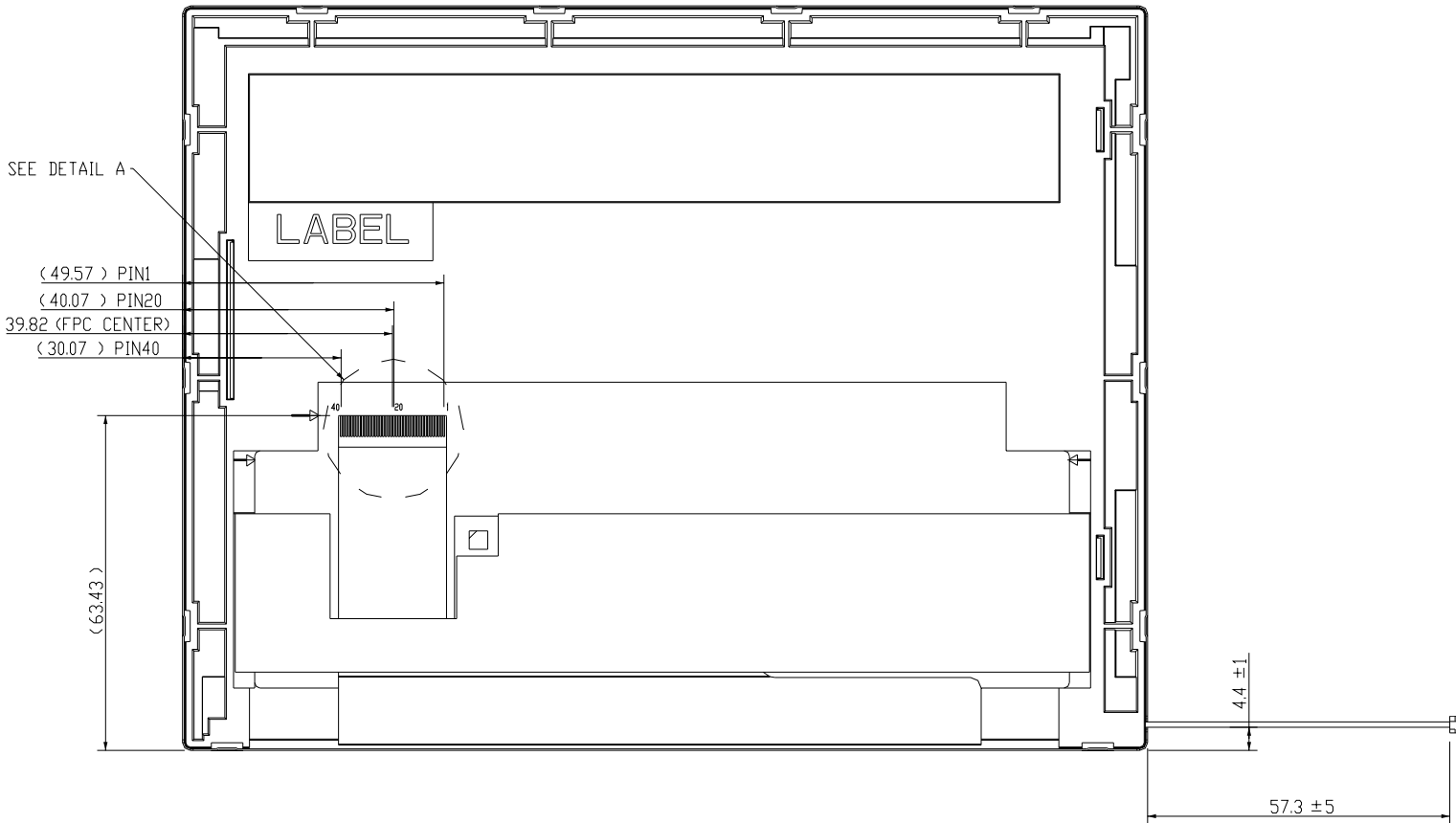

NOTE:

1. GENERAL TOLERANCE: ± 0.3mm
2. 6 O'CLOCK DIRECTION IS THE OPTIMUM VIEWING ANGLE.
3. SUGGEST CONNECTOR TYPE: STARCONN-89N40 or COMPATIBILITY.

8. OPTICAL CHARACTERISTICS

Ta=25°C

ITEM	SYMBOL	CONDITION	MIN.	TYP.	MAX.	UNIT	Remarks
Contrast	CR	$\theta = \phi = 0^\circ$ Point-5	450	500	--	--	*1)
Luminance	Luminance (CEN)	$\theta = \phi = 0^\circ$	200	250	--	cd/m ²	*2)
	Luminance Uniformity	$\theta = \phi = 0^\circ$	70	80	--	%	*2)
Color saturation			--	50		%	
Response Time	tr+tf	$\theta = \phi = 0^\circ$	--	25	30	ms	*3) *5)
View angle	Horizontal	CR \geq 10 Point-5	130	140	--	°	*4)
	Vertical		110	120	--	°	*4)
Color Coordinate	White	Wx Wy	0.273 0.289	0.313 0.329	0.353 0.369	--	*1)*2)*3)
	Red	Rx Ry	0.577 0.301	0.607 0.331	0.637 0.361	--	
	Green	Gx Gy	0.295 0.565	0.325 0.595	0.355 0.625	--	
	Blue	Bx By	0.117 0.065	0.147 0.095	0.177 0.125	--	

Remarks :

*1)Measure condition : 25°C \pm 2°C , 60 \pm 10%RH , under10 Lux in the dark room.BM-5A (TOPCON) , viewing angle2° , I_L=160mA , V_{CC}=3.3V.

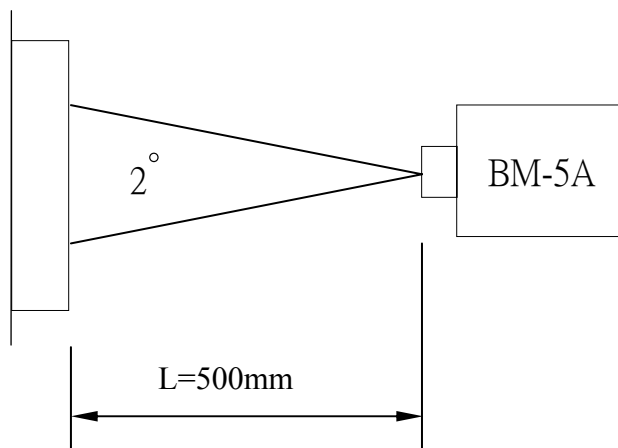

*2) Definition of contrast ratio :

Contrast Ratio (CR)= (White) Luminance of ON ÷ (Black) Luminance of OFF

*3) Definition of luminance :

Measure white luminance on the point 5 as figure8-1

Definition of Luminance Uniformity:

Measure white luminance on the point1~9 as figure8-1

$$\Delta L = [L(\text{Min})/L(\text{Max})] \times 100$$

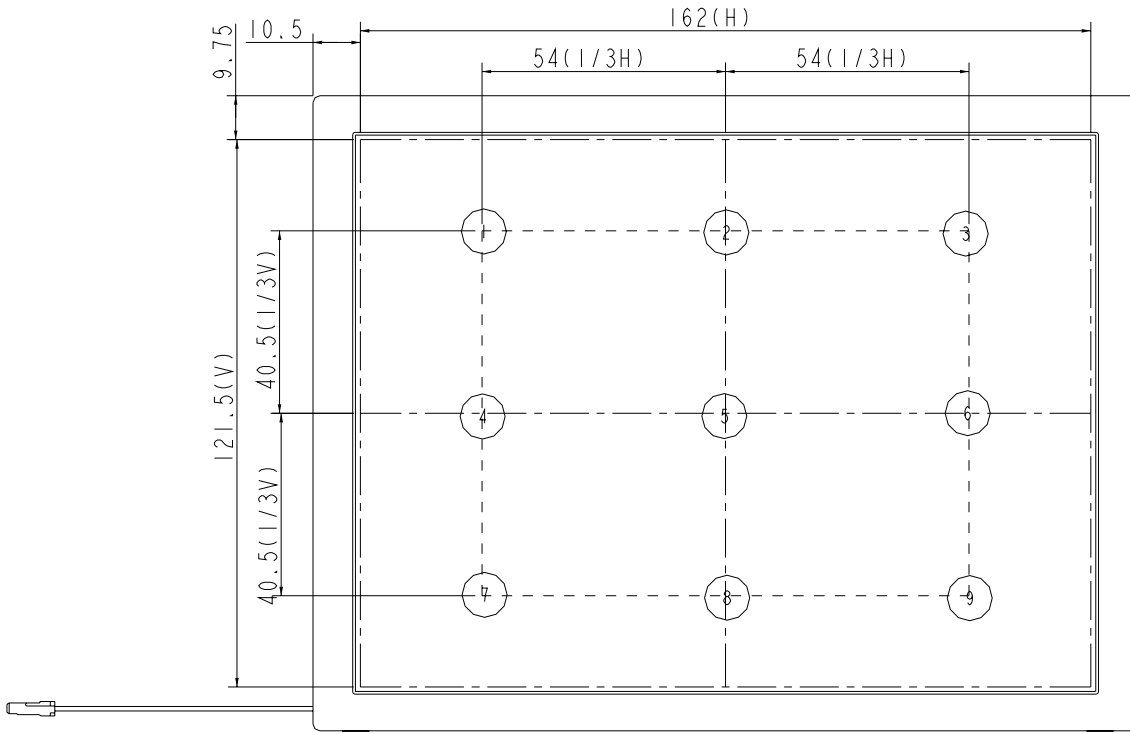

Fig8-1 Measuring point

*4) Definition of Viewing Angle(θ, ψ), refer to Fig8-2 as below :

These items are measured by EZ-CONTRAST(ELDIM) in the dark room. (no ambient light).

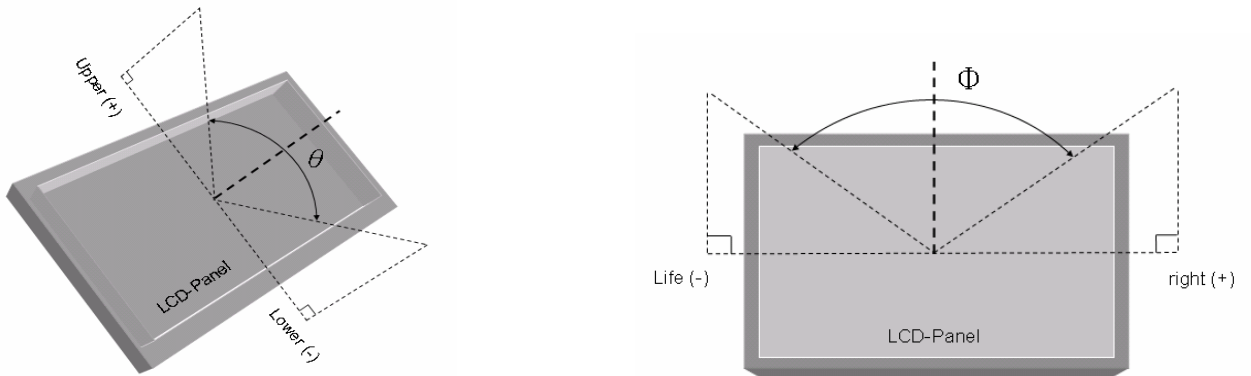

Fig8-2 Definition of Viewing Angle

*5) Definition of Response Time.(White-Black)

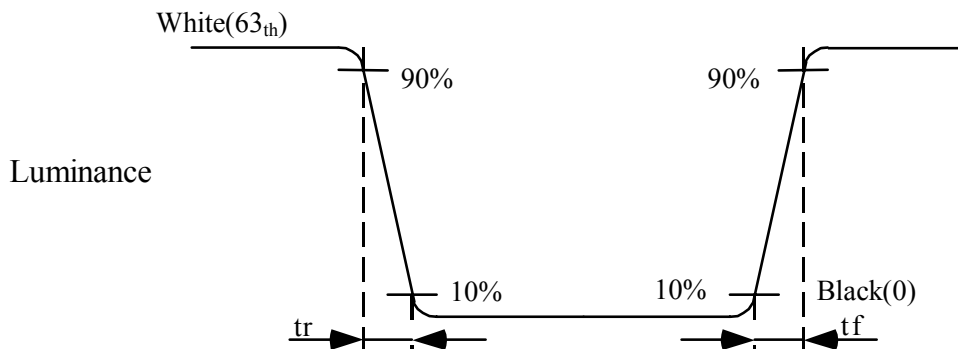

Fig8-3 Definition of Response Time(White-Black)

9. RELIABILITY TEST

9.1. Temperature and humidity

TEST ITEMS	CONDITIONS	REMARK
High Temperature Operation	70°C , 240Hrs	
High Temperature Storage	80°C , 240Hrs	
High Temperature High Humidity Operation	60°C , 90%RH , 240Hrs	No condensation
Low Temperature Operation	-30°C , 240Hrs	
Low Temperature Storage	-40°C , 240Hrs	
Thermal Shock	-30°C (0.5Hr) ~ 80°C(0.5Hr) 200 cycles	

9.2. Shock and Vibration

TEST ITEMS	CONDITIONS
Shock (Non-operation)	<ul style="list-style-type: none"> ● Shock level:980m/s²(equal to 100G) ● Waveform:half sinusoidal wave,6ms. ● Number of shocks:one shock input in each direction of three mutually perpendicular axes for a total of three shock inputs.
Vibration (Non-operation)	<ul style="list-style-type: none"> ● Frequency range:8~33.3Hz ● Stroke:1.3mm ● Vibration:sinusodial wave,perpendicularaxis(both x,z axis:2Hrs,y axis:4Hrs). ● Sweep:2.9G,33.3Hz-400Hz ● Cycle:15min

9.3. Judgment standard

The Judgment of the above test should be made as follow:

Pass:Normal display image with no obvious non-uniformity and no line defect.Partial transformation of the module parts should be ignored.

Fail:No display image,obvious non-uniformity,or line defect.