



Chunghwa Picture Tubes, Ltd.

Product Specification

To :
Date : 070830

TFT LCD
CLAA080JA11CW

ACCEPTED BY : Ver0.1
Tentative

APPROVED BY	CHECKED BY	PREPARED BY
張聖暉	李家銘	羅世奎

Prepared by :
Product Planning Management Division
Small & Medium TFT Product Business Unit
CHUNGHWA PICTURE TUBES, LTD.

1127 Hopin Rd., Padeh, Taoyuan, Taiwan 334, R.O.C.
TEL: +886-3-3675151 FAX: +886-3-377-3858

Doc.No:	SPEC_CLAA080JA11CW_V0.1_070830	Issue Date:	2007/08/14
---------	--------------------------------	-------------	------------

CONTENTS

1. OVERVIEW	4
2. ABSOLUTE MAXIMUM RATINGS	5
3. ELECTRICAL CHARACTERISTICS	5
4. INTERFACE CONNECTION.....	7
5. MECHANICAL DIMENSION.....	11
5.1 Front Side	11
5.2 Rear Side.....	11
6. OPTICAL CHARACTERISTICS	12
7. RELIABILITY TEST	13
7.1. Temperature and humidity	13
7.2. Shock and Vibration.....	14
7.3. Electrostatic Discharge	14

1. OVERVIEW

CLAB080JA11CW is 8" color TFT-LCD (Thin Film Transistor Liquid Crystal Display) module composed of LCD panel and driver ICs, control circuit and backlight.

The 8.0" screen produces 480(*3) x 220 WQVGA resolution image. By applying R.G.B. input signal, full color images are displayed.

General specification are summarized in the following table:

ITEM	SPECIFICATION
Display Area (mm)	180.72(H) × 94.27(V)
Number of Pixels	480 (H)x3(RGB) × 220(V)
Pixel Pitch (mm)	0.3765(H) ×0.4285(V)
Color Pixel Arrangement	RGB vertical stripe
Display Mode	Normally white, TN
Number of Colors	Full color
Optimum Viewing Angle	6 o'clock
Brightness (cd/m ²)	200nit(min)/250nit(typ)
Contrast Ratio	400:1(typ)
Response Time (ms)	30ms(typ)
Viewing Angle	120 degree(Horizontal) ; 110 degree(Vertical)
NTSC ratio	45%
Power Consumption	1.742 W (typ)
Module Size (mm)	193 (W) x 108.3(H) x 6.5(D)
Module Weight (g)	225(TYP)
Backlight Unit	LED
Surface Treatment	Anti-Glare

2. ABSOLUTE MAXIMUM RATINGS

The following are maximum values which, if exceeded, may cause faulty operation or damage to the unit.

ITEM	SYMBOL	MIN.	MAX.	UNIT	NOTE
Power Supply Voltage For LCD	VCC	-0.3	7.0	V	GND=0
	AVDD	-0.3	7	V	AVSS=0
	VGH	-0.3	25	V	GND=0
	VGL	-15	0.3	V	GND=0
Input Voltage	Vi	-0.2	AVDD+0.2	V	Note1
	VI	-0.3	VCC+0.3	V	Note2
Forward Current (per LED)	If		30	mA	
Reverse Voltage (per LED)	VR		5	V	
Pulse forward current (per LED)	I _{fp}		100	mA	Note3

[Note]

Note1 : Analog input voltage VR, VG, VB

Note2 : Logical signal STHL, STHR, OEH, L/R, CPH1~CPH3, STVR, STVL, OEV, CKV, U/D.

Note 3 : I_{fp} Conditions : Duty 1/10@1KHz

3. ELECTRICAL CHARACTERISTICS

(a) 3.1 Typical operation conditions (GND = Avss = 0V)

Ta=25°C

ITEM	SYMBOL	MIN	TYP	MAX	UNIT	NOTE
Power Supply Voltage	VCC	3	5	5.5	V	
	AVDD	4.5	5	5.5	V	
	VGH	17	18	19	V	
	VGL	-7	-6	-5	V	
Signal Amplitude (VR, VG, VB)	ViA	0.4	-	AVDD-0.4	V	Note1
	ViAC	-	4	-	V	Note1
	ViDC	-	AVDD/2	-	V	Note1
VCOM	V _{CAC}	4	5.6	6.5	V _{p-p}	Note1,2
	V _{CDC}	1.8	1.9	2.1	V	Note1,3
Input Signal Voltage	V _{IH}	0.7V _{CC}	-	V _{CC}	V	Note4
	V _{IL}	0	-	0.3V _{CC}	V	

[Note]

Note1 : Please refer to Fig.6

Note2 : Brightness level is adjusted by varying this amplitude V_{CAC}

Note3 : Please adjust V_{CDC} to make the flicker level be minimum.

Note4 : logical signal

STHL,STHR,OEH,L/R,CPH1~CPH3,STVR,STVL,OEV,CKV,U/D.

(b) Current consumption (GND = Avss = 0V)

ITEM	SYMBOL	CONDITION	MIN	TYP	MAX	UNIT	NOTE
Drive Current	I _{GH}	V _{GH} = 18V	-	0.12	1	mA	
	I _{GL}	V _{GL} = -6V	-	0.45	1	mA	
	I _{CC}	V _{CC} = 5V	-	2.5	4.5	mA	
	I _{DD}	AV _{DD} = 5V	-	9	24	mA	

(c) Timing characteristics of input signals:

CHARACTERISTICS	SYMBOL	MIN	TYP	MAX	UNIT	NOTE
1 Field scanning period	T _{IV}	-	262.5	-	H	
1 Line scanning period	T _{IH}	-	63.5	-	μs	
Source driver operating frequency	F _{OP}	-	9.6	-	MHz	
CLK pulse width	T _{CW}	75	104	2000	ns	
CLK pulse high period	T _{CWH}	40	50	60	% T _{CW}	
CLK pulse low period	T _{CWL}	40	50	60	% T _{CW}	
CLK pulse delay	T _{C12} T _{C23} T _{C31}	12	35	1000	ns	CPH1~CPH 3
STH start pulse width	T _{STH}	32	107	-	ns	STHR,STHL
STH start pulse setup time	T _{SUH}	16	35	-	ns	STHR,STHL
STH start pulse hold time	T _{HDH}	16	72	-	ns	STHR,STHL
OEH output enable pulse width	T _{OEH}	1			T _{CW}	OEH
Sample and hold disable time OEH& STH	T _{OEH-STH}	-	8.2	-	μs	OEH-STH
CLKV pulse width	T _{CKVW}	5	64	-	μs	CKV
CLKV pulse high period	T _{CKVH}	2.5	16.5	-	μs	CKV
CLKV pulse low period	T _{CKVL}	1	47	-	μs	CKV
STV start pulse width	T _{STV}	0.5	64	-	μs	STVR, STVL
STV start pulse setup time	T _{SUV}	0.2	50	-	μs	STVR, STVL
STV start pulse hold time	T _{HDV}	0.3	15	-	μs	STVR,STVL

< Note1 > 1. High level of source driver and gate driver logic signal are 70%

2. Low level of source driver and gate driver logic signal are 30%

< Note2 > Please refer to Fig. 4 and Fig. 5

(d) Sequence for power on/off and signal on/off

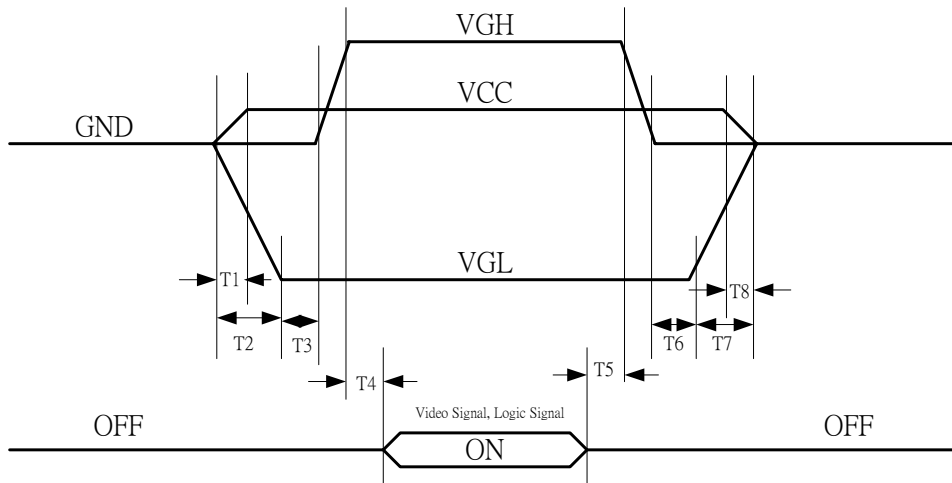

$$0 < T1 < T2 \leq 20\text{ms}$$

$$T3 \leq 10\text{ms}$$

$$T4 \leq 10\text{ms}$$

$$T5 \leq 10\text{ms}$$

$$T6 \leq 10\text{ms}$$

$$T8 < T7 \leq 10\text{ms}$$

(e) Backlight

a. Electrical Characteristics
 Ta=25°C

ITEM	SYMBOL	MIN	TYP	MAX	UNIT	NOTE
LED current	IL	--	140	--	mA	Note 1
LED voltage	VL	--	12	--	V	Note 1
Power consumption	WL	--	1.68	--	W	Note 1

< Note1 > LED B/L circuit如下圖,A : Anode,K : Cathode。

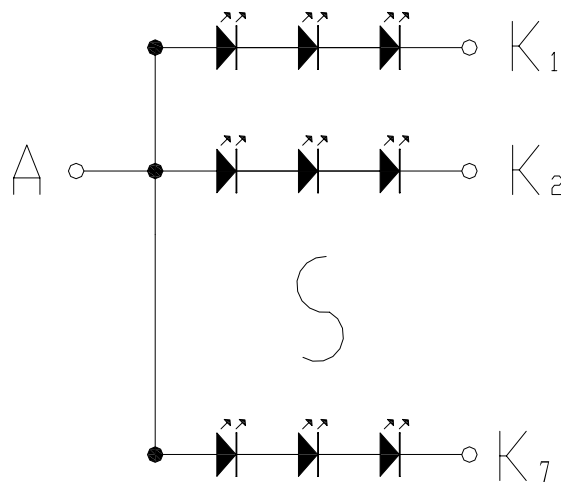

4. INTERFACE CONNECTION

(a.) CN1

Pin No.	SYMBOL	I/O	FUNCTION	NOTE
1	GND	-	Digital ground pin for Gate driver	
2	VCC		Supply power for gate digital circuit	
3	VGL		Gate driver negative voltage	
4	VGH		Gate driver positive voltage	
5	STVD	I/O	Gate scanning start signal	Note 1
6	STVU	I/O	Gate scanning start signal	Note 1
7	CKV		Gate driver scanning clock pulse	
8	U/D		Up/Down scanning change	Note 1
9	OEV		Gate driver output enable	
10	VCOM		Voltage applied to color filter substrate	
11	VCOM		Voltage applied to color filter substrate	
12	L/R		Left / Right scanning change	Note 2
13	MOD		Sampling mode change (H: Simultaneous, L: Sequential)	Note 3
14	OEH		Source driver output enable	
15	STHL	I/O	Source scanning start signal	Note 2
16	STHR	I/O	Source scanning start signal	Note 2
17	CPH3		Source driver clock input 3	
18	CPH2		Source driver clock input 2	
19	CHP1		Source driver clock input 1	
20	VCC		Supply power for source digital circuit	
21	GND	-	Digital ground pin for source driver	
22	VR		Red video signal	
23	VG		Green video signal	
24	VB		Blue video signal	
25	AVDD		Supply power for analog circuit	
26	AVSS	-	Analog ground pin	

Note1 : The function of STVD and STVU is changed as follows by the U/D terminal (up/down scanning)

U/D	STVD	STVU
H(VCC)	Signal Input	Signal Output
L(GND)	Signal Output	Signal Input

Note2 : The function of STHR and STHL is changed as follows by the L/R terminal(right/left scanning)

L/R	STHL	STHR
H(VCC)	Signal Input	Signal Output
L(GND)	Signal Output	Signal Input

Note3 : MOD=H:Simultaneous sampling (Set CPH2 and CPH3 to GND)
MOD=L:Sequential sampling

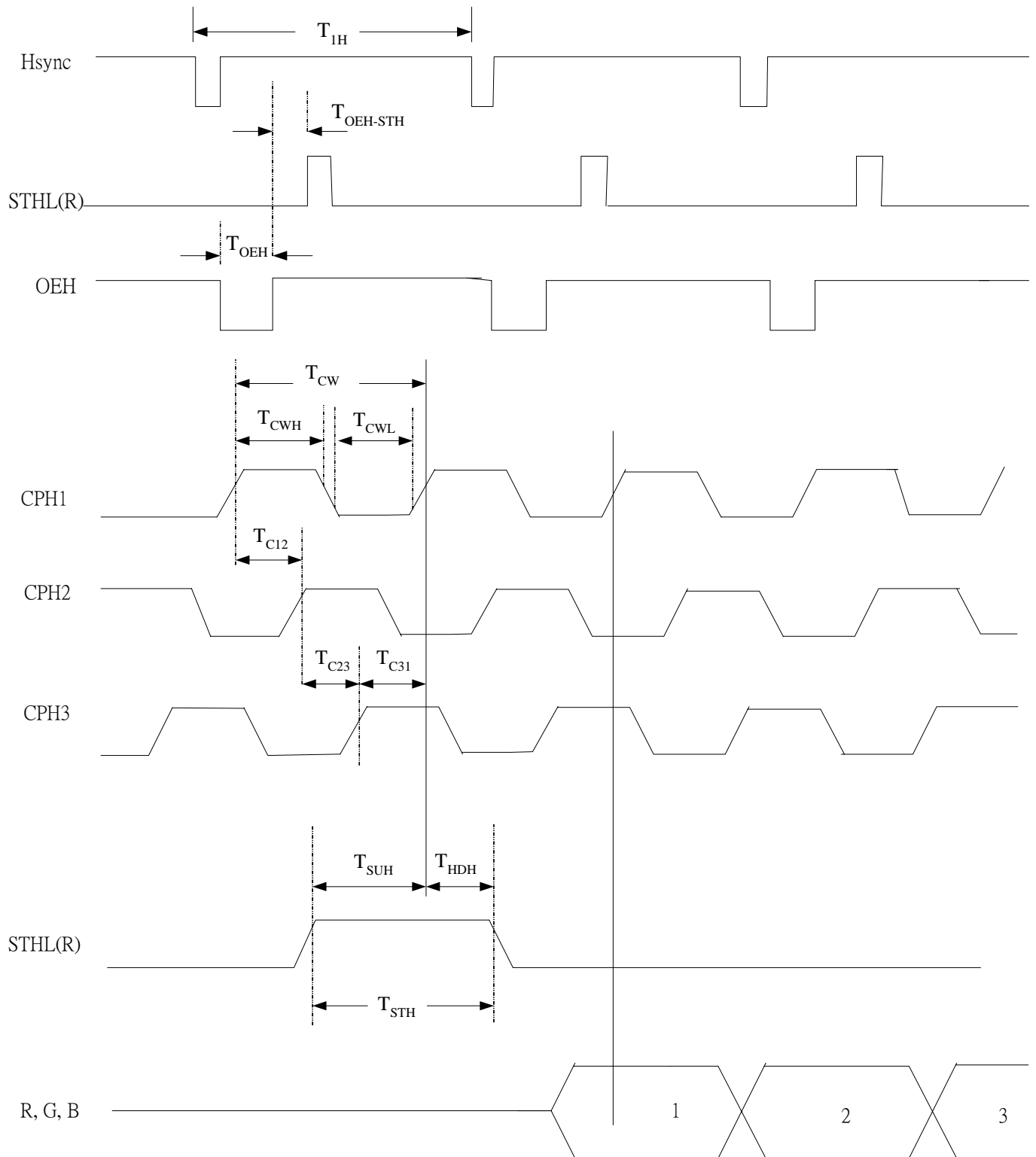

Fig.4 Horizontal Timing sequence

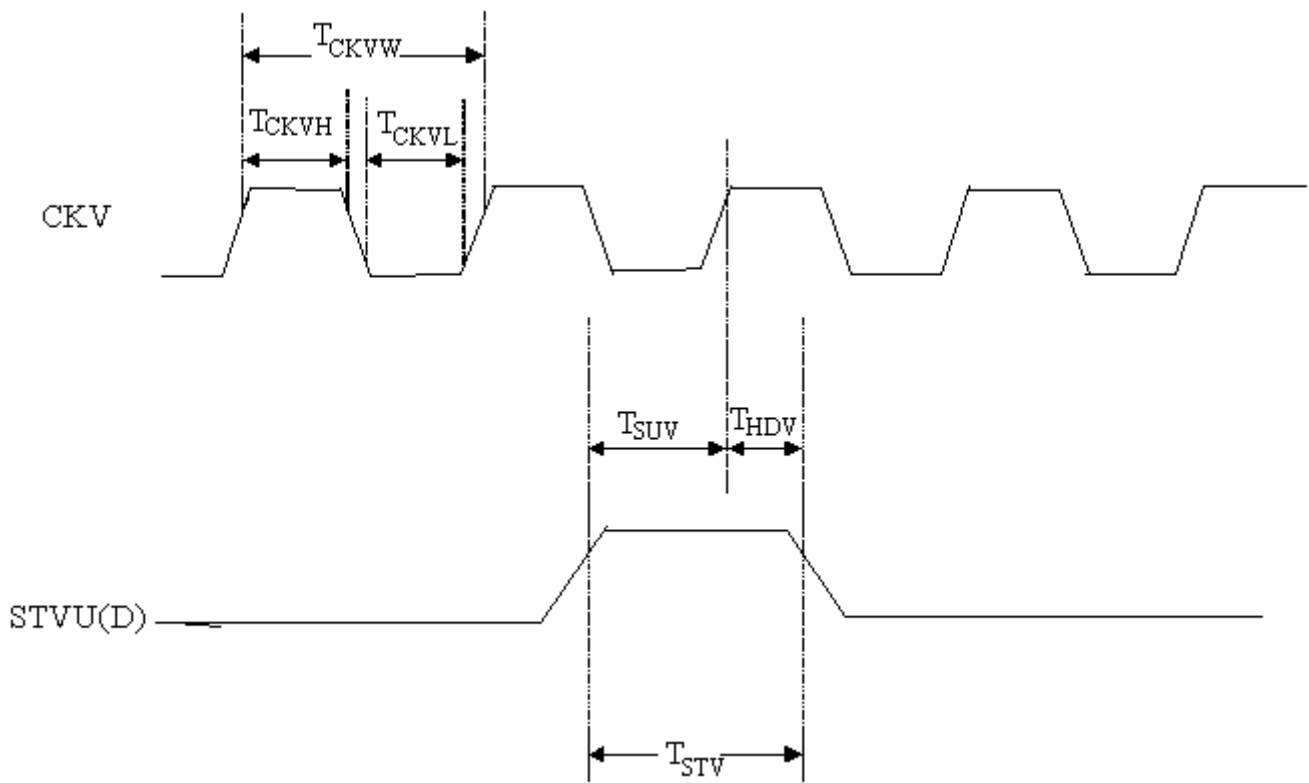

Fig.5 Vertical Timing sequence

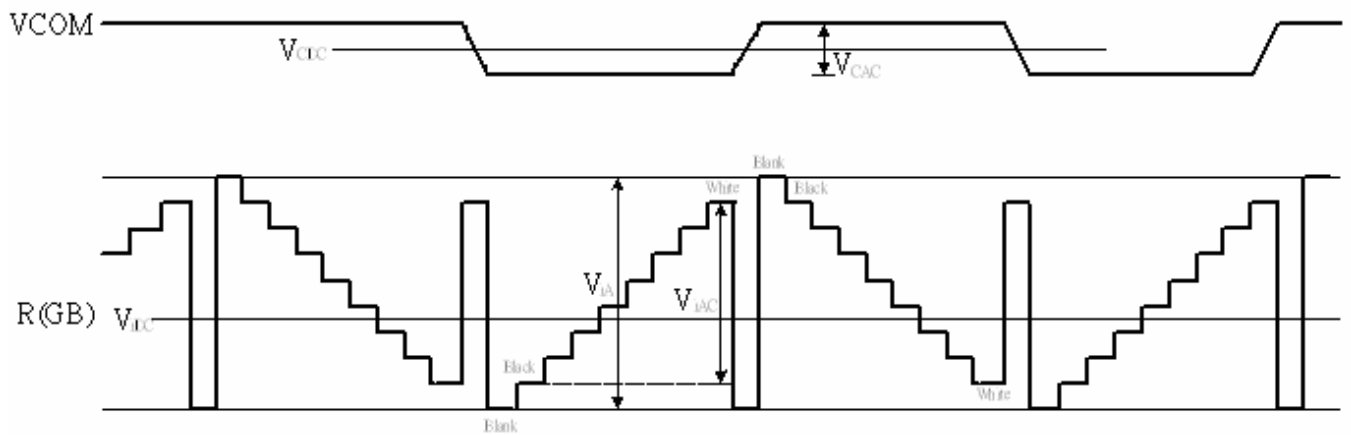
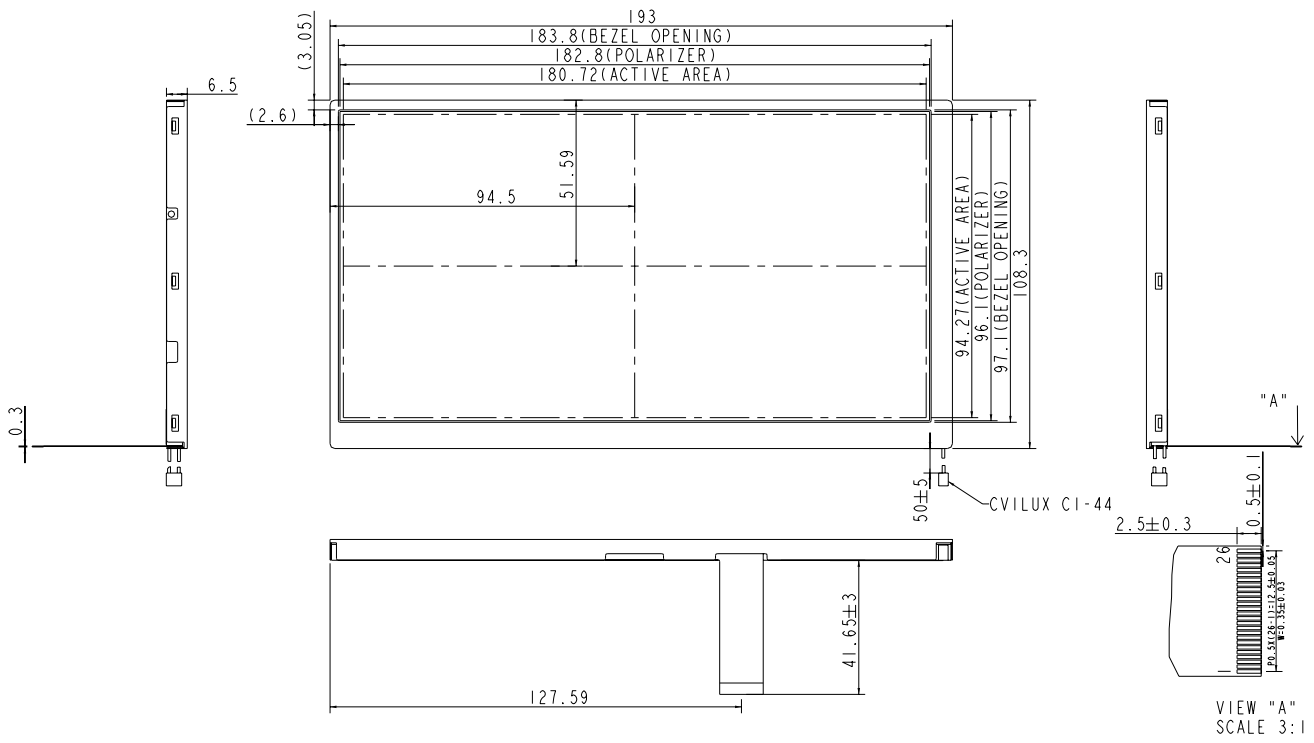

Fig.6 VCM-RGB

5. MECHANICAL DIMENSION

5.1 Front Side

[Unit : mm]



VIEW "A"
SCALE 3:1

5.2 Rear Side

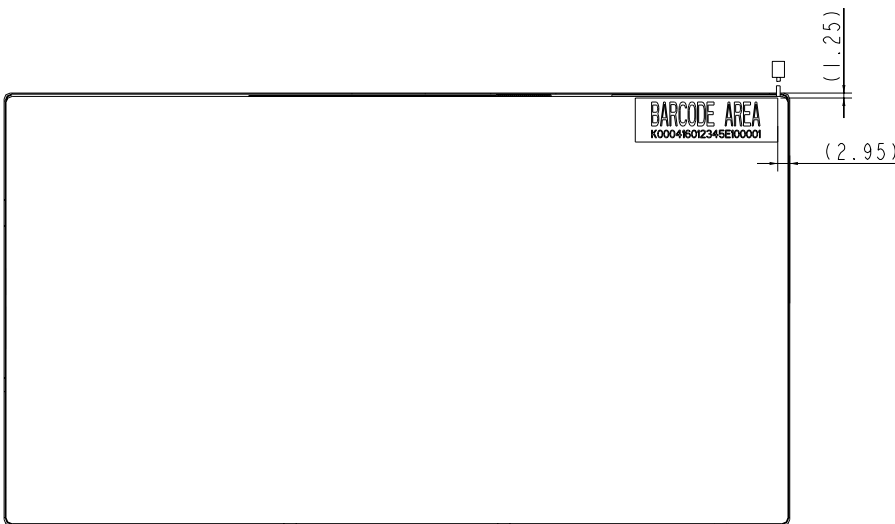

NOTE :
UNDEFINED TOLERANCE TO BE ±0.3mm

6. OPTICAL CHARACTERISTICS

Ta = 25°C, VCC=3.3V

ITEM	SYMBOL	MIN.	TYP.	MAX.	UNIT	NOTE
Contrast	CR	320	400	--	--	*1)
Luminance (CEN)	L	200	250	--	cd/m ²	I _L = 20 mA
Luminance Uniformity	ΔL	70	80	--	%	*2)
Color saturation		40	45		%	
Response Time	T	--	30	45	ms	*4)
View angle	Horizontal ψ	100	120		°	*3)
	Vertical θ	90	110		°	*3)
Color Coordinate	White	x y	0.273 0.289	0.313 0.329	0.353 0.369	θ = φ = 0°
	Red	x y	TBD	TBD	TBD	θ = φ = 0°
	Green	x y	TBD	TBD	TBD	θ = φ = 0°
	Blue	x y	TBD	TBD	TBD	θ = φ = 0°

[Note]

- These items are measured by BM-5A (TOPCON) in the dark room. (no ambient light).

*1) Definition of contrast ratio :

Measure contrast ratio on the #5 point (refer to figure 1).

Contrast ratio is calculated with the following formula :

Contrast Ratio (CR)= (White) Luminance of ON ÷ (Black) Luminance of OFF

*2) Definition of Luminance Uniformity :

Measure maximum luminance(L(MAX))and minimum luminance (L(MIN))on the 9 points as figure 1(#1~#9 poin).Luminance Uniformity is calculated with the following formula :

$$\Delta L = (L(\text{MIN}) \div L(\text{MAX})) \times 100$$

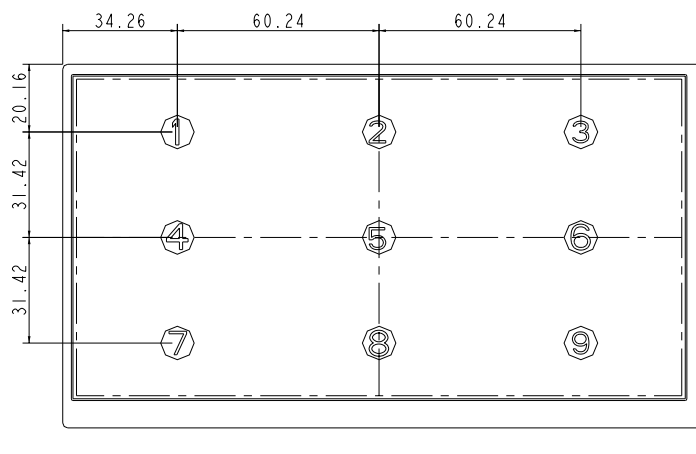

Fig.1 Measuring point

*3) Definition of Viewing Angle(θ,ψ),refer to Fig.2 as below :

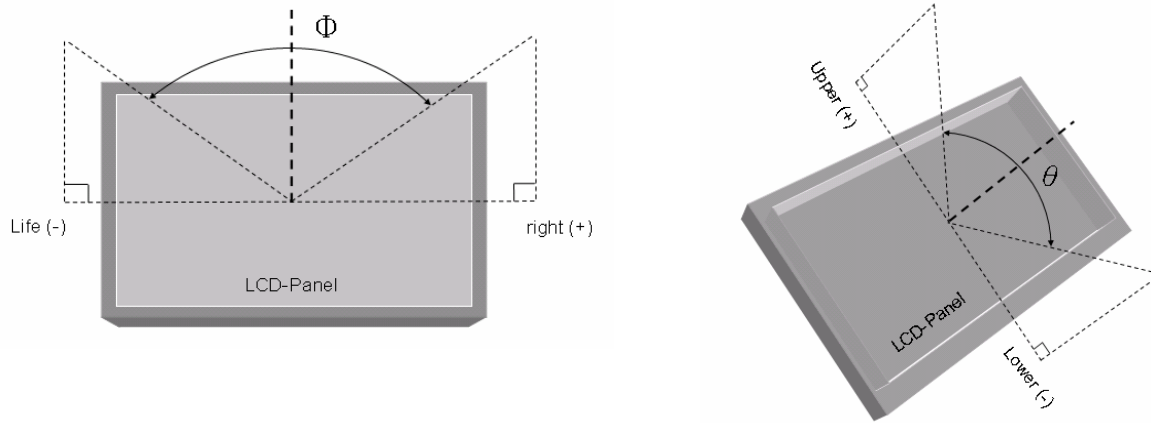

Fig.2 Definition of Viewing Angle

*4) Definition of Response Time.

The response time is defined as the time interval between the 10% and 90% amplitudes. Refer to figure 3 as below.

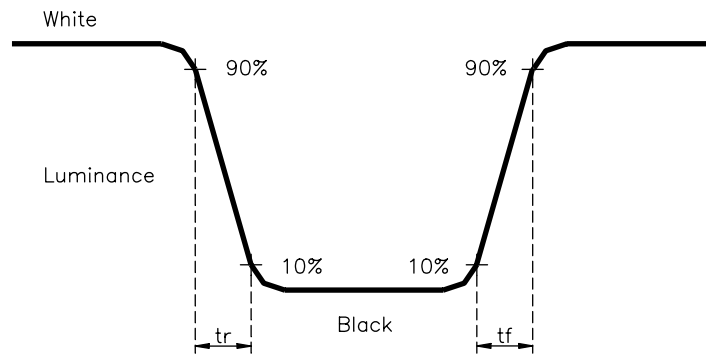

Fig.3 Definition of Response Time

7. RELIABILITY TEST

7.1. Temperature and humidity

TEST ITEMS	CONDITIONS
High Temperature Operation	85°C; 240hrs
High Temperature High Humidity Operation	60°C; 90%RH; 240hrs (No condensation)
High Temperature Storage	95°C; 240hrs
Low Temperature Operation	-30°C; 240hrs (Backlight unit always turn on)
Low Temperature Storage	-40°C; 240hrs
Thermal Shock (No operation)	Between -30°C (0.5hr) and 85°C (0.5hr); 200 Cycles

7.2. Shock and Vibration

ITEMS	CONDITIONS
Shock (Non-Operation)	980m/S ² (equal to 100G), 6ms, (1/2 Sine wave), Each axis X,Y,Z.
Vibration (Non-Operation)	Frequency range:8~33.3Hz Stoke : 1.3 mm Vibration: sinusoidal wave, perpendicular axis(both x,z axis: 2Hrs , y axis: 4Hrs). Sweep: 2.9G, 33.3~400Hz Cycle: 15 min

7.3. Electrostatic Discharge

TEST ITEM	CONDITIONS	Note
ESD	150pF , 330Ω , ±8kV&±15kV air & contact test	(1)
	200pF , 0Ω , ±200V contact test	(2)

[NOTE]Measure point :(1)LCD glass and metal bezel
(2)IF connector pins

(4) The judgment of the above test should be made as follow:

Pass: Normal display image with no obvious non-uniformity and no line defect.

(Partial transformation of the module parts should be ignored.)

Fail: No display image, obvious non-uniformity, or line defects.