



Chunghwa Picture Tubes, Ltd.

Technical Specification

To :

Date : 2005/2/25

TFT LCD

CLAA070WA03

ACCEPTED BY :

APPROVED BY	CHECKED BY	PREPARED BY

Prepared by : TFT Business Unit
Small & Medium Product General Division
CHUNGHWA PICTUER TUBES, LTD.

1127 Hopin Rd., Padeh, Taoyuan, Taiwan 334, R.O.C.
TEL: +886-3-3675151 FAX: +886-3-377-3001

Doc.No:	CLAA070WA03-tentative-2005/2/25	Issue Date:	
---------	---------------------------------	-------------	--

REVISION STATUS

Revision Notice	Description	Page	Rev. Date
V.0	First revision (Tentative)	-	2005/2/25

1. OVERVIEW

CLAA070WA03 is 7" color TFT-LCD (Thin Film Transistor Liquid Crystal Display) module composed of LCD panel , driver ICs, control circuit, and backlight. Utilizes a panel with a 16:9 aspect ratio.

The 7.0" screen produces a high resolution image that is composed of 112,320(480×234) pixel elements in a stripe arrangement. Inverter for backlight is not included in this module.

General specifications are summarized in the following table:

ITEM	SPECIFICATION
Display Area(mm)	154.08(H) x 86.58(V) (7-inch diagonal)
Number of Pixels(dot)	480(H) X 3(RGB) X 234(V)
Pixel Pitch(mm)	0.321(H) x 0.37(V)
Color Pixel Arrangement	RGB vertical stripe
Display Mode	normally white TN
Number of Colors	Full color
Optimum Viewing Angle	6 o'clock
Brightness(cd/m ²)	350 (6.0mA)
Video Signal Interface	Analog Video Interface
Module Size(mm)	164.9(W) x 100.0(H) x 5.7(D)Typ.
Module Weight(g)	160(Max)
Backlight Unit	CCFL , 1 tube
Surface Treatment	Anti-Glare

The LCD Products listed on this document are not suitable for use of aerospace equipment, submarine cables, nuclear reactor control system and life support systems. If customers intend to use these LCD products for above application or not listed in "Standard" as follows, please contact our sales people in advance.

Standard: The applications are Portable DVD, Multimedia applications and others AV system.

2. ABSOLUTE MAXIMUM RATINGS

Item	Symbol	Condition	Min.	Max.	Unit	Remark
Power voltage	V _{CC}	GND=0	-0.3	7	V	
	AV _{DD}	AV _{SS} =0	-0.3	7	V	
	V _{GH}	GND=0	-0.3	18	V	
	V _{GL}		-15	0.3	V	
	V _{GH} -V _{GL}		-	33	V	
Input signal voltage	V _i		-0.3	AV _{DD} +0.3	V	*1)
	V _I		-0.3	V _{CC} +0.3	V	*2)
	V _{COM}		-2.9	5.2	V	

*1) VR, VG, VB

*2) STHL, STHR, OEH, L/R, CPH1~CPH3, STVR, STVL, OEV, CKV, U/D.

3. ELECTRICAL CHARACTERISTICS

(a) Typical operation conditions (GND = AV_{SS} = 0 V)

T_a=25°C

Parameter	Symbol	Min.	Typ.	Max.	Unit	Remark
Power supply	V _{CC}	4.5	5	5.5	V	
	AV _{DD}	4.5	5	5.5	V	
	V _{GH}	14.3	15	15.7	V	
	V _{GL}	-	-6	-	V	
Video signal amplitude (VR, VG, VB)	V _{iA}	0.4	-	AV _{DD} -0.4	V	Note1
	V _{iAC}	-	1.8	2.8	V	
	V _{iDC}	-	AV _{DD} /2	-	V	
VCOM	V _{CAC}	3.8	4.2	4.6	Vp-p	
	V _{CDC}	1.7	1.85	2.0	V	
Input signal voltage	V _{IH}	0.8V _{CC}	-	V _{CC}	V	Note2
	V _{IL}	0	-	0.2V _{CC}	V	

Note1 : Refer to Fig.5

Note2 : STHL,STHR,OEHL,L/R,CPH1~CPH3,STVR,STVL,OEVL,CKV,U/D.

(b) Current consumption (GND = AV_{SS} = 0 V)

Parameter	Symbol	Condition	Min.	Typ.	Max.	Unit	Remark
Current for Driver	I _{GH}	V _{GH} =15V	-	0.20	0.5	mA	
	I _{GL}	V _{GL} =-10V	-	0.80	1.5	mA	
	I _{CC}	V _{CC} =5V	-	3.0	6.0	mA	
	I _{DD}	AV _{DD} =5V	-	17.0	30	mA	

(c) Backlight driving condition

T_a=25°C

Parameter	Symbol	Condition	Min.	Typ.	Max.	Unit
Lamp voltage(I _L =6.0mA)	V _L	-		521	590	V _{rms}
Lamp current	I _L			6.0	7.0	mA
Frequency	F _L	*1)		50	80	kHz
Lamp lift time	Life L	*2)	10,000	-		Hr
Lamp starting voltage	T _a =0°C	V _s	*3)	-	-	940
	T _a =25°C		*3)	-	-	830

[Note] : Sign "()" means tentative value.

*1) The time that module luminance reduced to 50% of initial value, Base on T_a=25°C, I_L=6mA continuous. °

*2) "Life time" is defined as the lamp brightness decrease to 50% original brightness at I_L=6.0mA, continuous lighting, T_a=25°C. °

*3) For starting the backlight unit, the output voltage of DC/AC's transformer should be larger than the maximum lamp starting voltage. °

(d) Panel timing

Parameter	Symbol	Min.	Typ.	Max.	Unit	Remark
Rising time	t_r	-	-	10	ns	Note 1
Falling time	t_f	-	-	10	ns	
High and low level pulse width	t_{CPH}	99	103.7	107	ns	CPH1~CPH3
CPH pulse duty	t_{CWH}	25	33.2	60	%	CPH1~CPH3
CPH pulse delay	t_{C12} t_{C23} t_{C31}	30	37	$t_{CPH}/2$	ns	CPH1~CPH3
STH setup time	t_{SUH}	20	57.5	-	ns	STHR,STHL
STH hold time	t_{HDH}	20	42	-	ns	STHR,STHL
STH pulse width	t_{STH}	-	104.5	-	t _{cph}	STHR,STHL
STH period	t_H	61.5	63.5	65.5	μs	STHR,STHL
OEH pulse width	t_{OEH}	-	2.93	-	μs	OEH
Sample and hold disable time	t_{DIS1}	-	8.5	-	μs	
OEV pulse width	t_{OEV}	-	5.18	-	μs	OEV
CKV pulse width	t_{CKV}	-	15.7	-	μs	CKV
Clean enable time	t_{DIS2}	-	2.54	-	μs	
STV setup time	t_{SUV}	-	47.8	-	ns	STVL,STVR
STV hold time	t_{HDV}	-	15.7	-	ns	STVL,STVR
STV pulse width	t_{STV}	-	63.5	-	t _H	STVL,STVR
VCOM rising time	t_{rCOM}		3	5	μs	
VCOM falling time	t_{fCOM}		2.41	5	μs	

Note 1 : For all of the logic signals.

Note 2 : Timing Diagram

Please refer to the attached drawing ,from Fig.4 to Fig.7.

4. INTERFACE CONNECTION

(1) CN1 (INTERFACE SIGNAL)

Pin No.	Symbol	I/O	Function	Remark
1	GND	-	Ground for logic circuit	
2	V _{CC}	I	Supply voltage of logic control circuit for scan driver	
3	V _{GL}	I	Negative power for scan driver	
4	V _{GH}	I	Positive power for scan driver	
5	STVR	I/O	Vertical start pulse	Note 1
6	STVL	I/O	Vertical start pulse	Note 1
7	CKV	I	Shift clock input for scan driver	
8	U/D	I	UP/DOWN scan control input	Note 1
9	OEV	I	Output enable input for driver	
10	VCOM	I	Common electrode driving signal	
11	VCOM	I	Common electrode driving signal	
12	L/R	I	LEFT/RIGHT scan control input	Note 1
13	MOD	I	Sequential sampling and simultaneous sampling setting	Note 2
14	OEH	I	Output enable input for data driver	
15	STHL	I/O	Start pulse for horizontal scan line	Note 1
16	STHR	I/O	Start pulse for horizontal scan line	Note 1
17	CPH3	I	Sampling and shifting clock pulse for data drive	
18	CPH2	I	Sampling and shifting clock pulse for data drive	
19	CHP1	I	Sampling and shifting clock pulse for data drive	
20	V _{CC}	I	Supply voltage of logic control circuit for data driver	
21	GND	-	Ground for logic circuit	
22	VR	I	Alternated video signal input(Red)	
23	VG	I	Alternated video signal input(Green)	
24	VB	I	Alternated video signal input(Blue)	
25	AV _{DD}	I	Supply voltage for analog circuit	
26	AV _{SS}	-	Ground for analog circuit	

Note1 :

Setting of scan control input		IN/OUT state for start pulse				Scanning direction
U/D	L/R	STVR	STVL	STHR	STHL	
GND	V _{CC}	OUT	IN	OUT	IN	From up to down ,and from left to right
V _{CC}	GND	IN	OUT	IN	OUT	From down to up ,and from right to left
GND	GND	OUT	IN	IN	OUT	From up to down ,and from right to left
V _{CC}	V _{CC}	IN	OUT	OUT	IN	From down to up ,and from left to right

Note2 : MOD=H:Simultaneous sampling. (Please set CPH2 and CPH3 to Ground)

MOD=L:Sequential sampling.

(b) CN2 (BACK LIGHT)

Backlight-side connector: BHSR-02VS-1 (JST made)

Inverter-side connector: SM02B-BHSS-1 (JST)

Pin No.	Symbol	Function
1	CTH	VBLH (High voltage)
3	CTL	VBLL (Low voltage)

[Note] : VBLH-VBLL=VL

5. MECHANICAL DIMENSION

(1) Front / Rear side

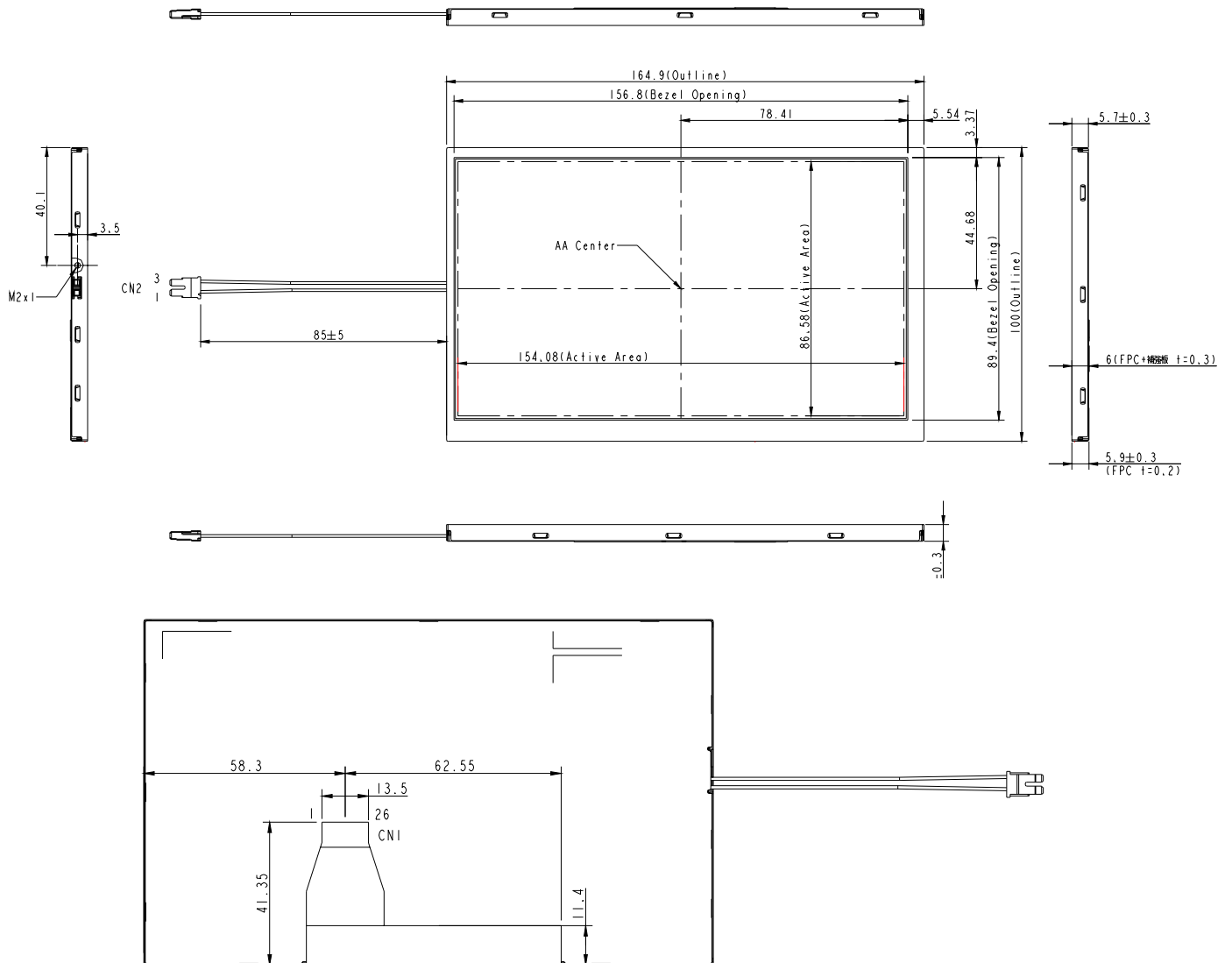

[Note]

1. Undefined tolerances to be ±0.5 mm.
2. CN2 BHSR-02V-1 (JST)

[Note] Undefined tolerances to be ±0.5 mm

[unit : mm]

6. OPTICAL CHARACTERISTICS

Ta=25°C , VCC=3.3V

ITEM	SYMBOL	CONDITION	MIN.	TYP.	MAX.	UNIT
Contrast Ratio	CR	*1)	350	400	--	--
Luminance *)	L	*2) I _L = 6.0mA	--	350	--	cd/m ²
5P Luminance			--	280		
Luminance Uniformity	ΔL	*4)	--	--	30	%
Response Time	T _r	*5)	--	12	-	ms
	T _f		--	18	-	ms
Viewing Angle	Horizontal	φ *3)	CR ≥ 10	45~45	--	°
	Vertical			θ *3)	25~35	--
Color Coordinate	White	x	0.27	0.30	0.33	--
		y	0.28	0.31	0.34	

[Note]

- These items are measured by BM-5A (TOPCON) or CA-1000(MINOLTA) in the dark room (no ambient light).
- Brightness conditions : I_L = 6.0 mA , Inverter:HIU-766 (52K) (Harison made)

*1) Definition of contrast ratio :

Measure contrast ratio on the below 5 points (refer to figure1, #1~#5 point) and take the average value.

Contrast ratio is calculated with the following formula :

$$\text{Contrast Ratio (CR)} = (\text{White})\text{Luminance of ON} \div (\text{Black})\text{Luminance of OFF}$$

*2) Definition of luminance :

Measure white luminance on the same 5 points and take the average value.

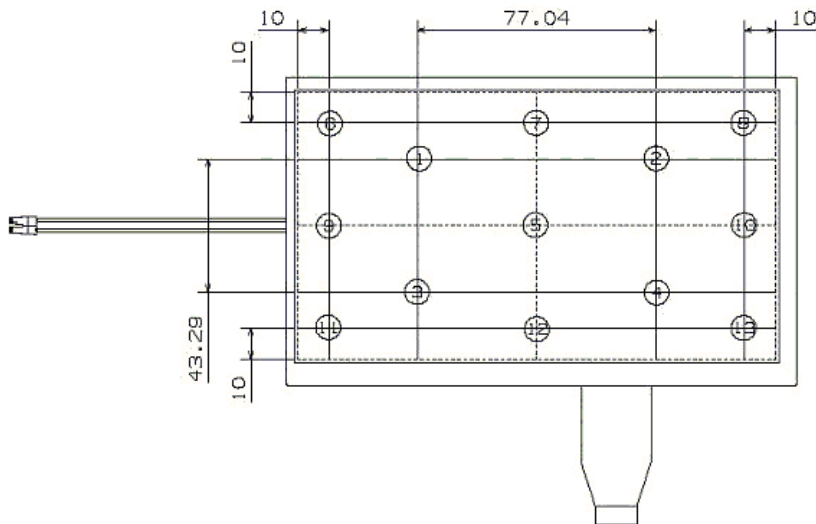

Fig.1 Measuring point

*3) Definition of Viewing Angle(θ , ϕ),refer to Fig.2 as below :

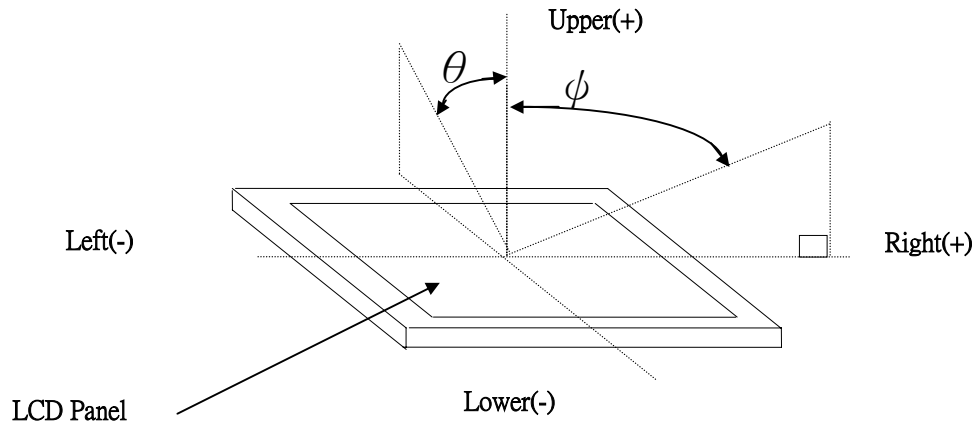

Fig.2 Definition of Viewing Angle

*4) Definition of Luminance Uniformity

Measure maximum luminance(L(MAX))and minimum luminance (L(MIN))on the 5 points as figure 1.Luminance Uniformity is calculated with the following formula :

$$\Delta L = [L(\text{MAX})/L(\text{MIN})-1] \times 100$$

*5) Definition of Response Time.

The response time is defined as the time interval between the 10% and 90% amplitudes.Refer to figure 3 as below.

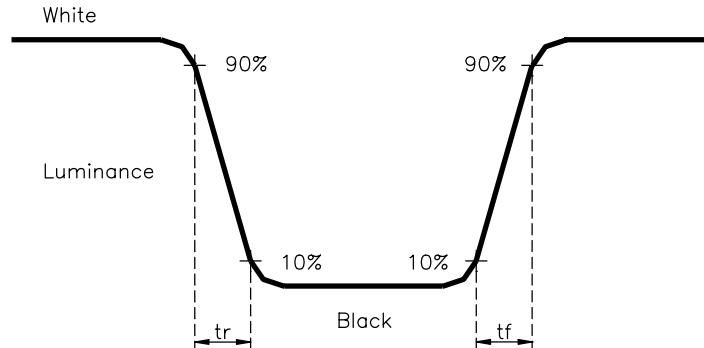

Fig.3 Definition of Response Time

7. RELIABILITY TEST CONDITIONS

(1) Temperature and Humidity

TEST ITEMS	CONDITIONS
HIGH TEMPERATURE OPERATION	60° C ; 240Hrs
HIGH TEMPERATURE AND HIGH HUMIDITY OPERATION	40° C ; 95% RH ; 240Hrs
HIGH TEMPERATURE AND HIGH HUMIDITY STORAGE	60° C ; 90% RH Max. ; 48Hrs
HIGH TEMPERATURE STORAGE	70° C ; 240Hrs
LOW TEMPERATURE OPERATION	0° C ; 240Hrs, Backlight unit always turn on
LOW TEMPERATURE STORAGE	-25° C ; 240Hrs
THERMAL SHOCK (No operation)	-20° C (1Hr)~60° C (1Hr) 200 CYCLE

(2) Shock & Vibration

TEST ITEMS	CONDITIONS
SHOCK (NON-OPERATION)	<ul style="list-style-type: none"> ● Shock level: 980m/s²(equal to 100G). ● Waveform: half sinusoidal wave,6ms. ● Number of shocks: one shock input in each direction of three mutually perpendicular axes for a total of three shock inputs.
VIBRATION (NON-OPERATION)	<ul style="list-style-type: none"> ● Frequency range: 8~33.3Hz ● Stoke : 1.3 mm ● Vibration: sinusoidal wave, perpendicular axis(both x,z axis: 2Hrs , y axis: 4Hrs). ● Sweep: 2.9G, 33.3~400Hz ● Cycle: 15 min

(3) Judgment standard

The judgment of the above test should be made as follow:

Pass: Normal display image with no obvious non-uniformity and no line defect. Partial transformation of the module parts should be ignored.

Fail: No display image, obvious non-uniformity, or line defects.

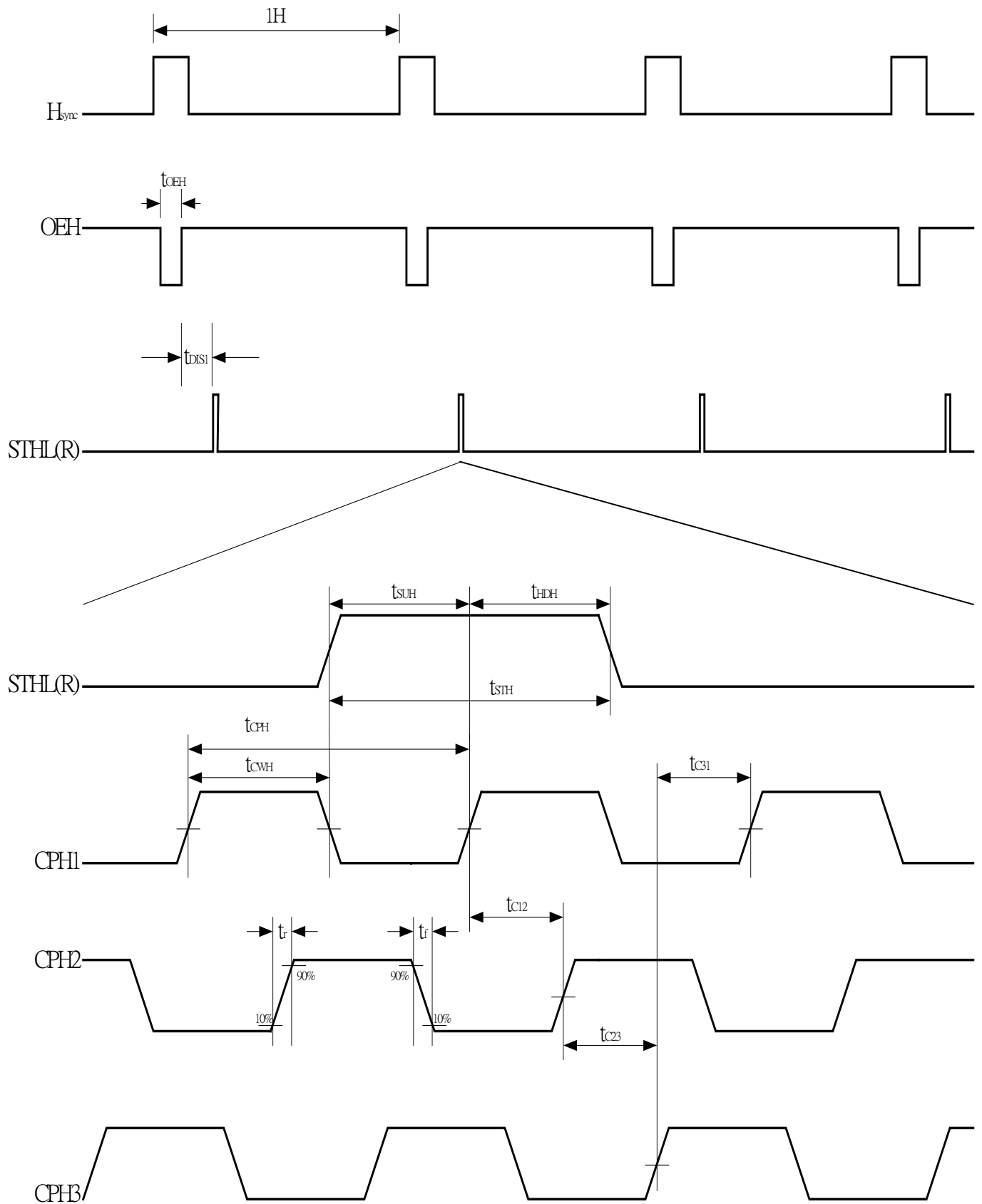

Fig.4 Horizontal timing

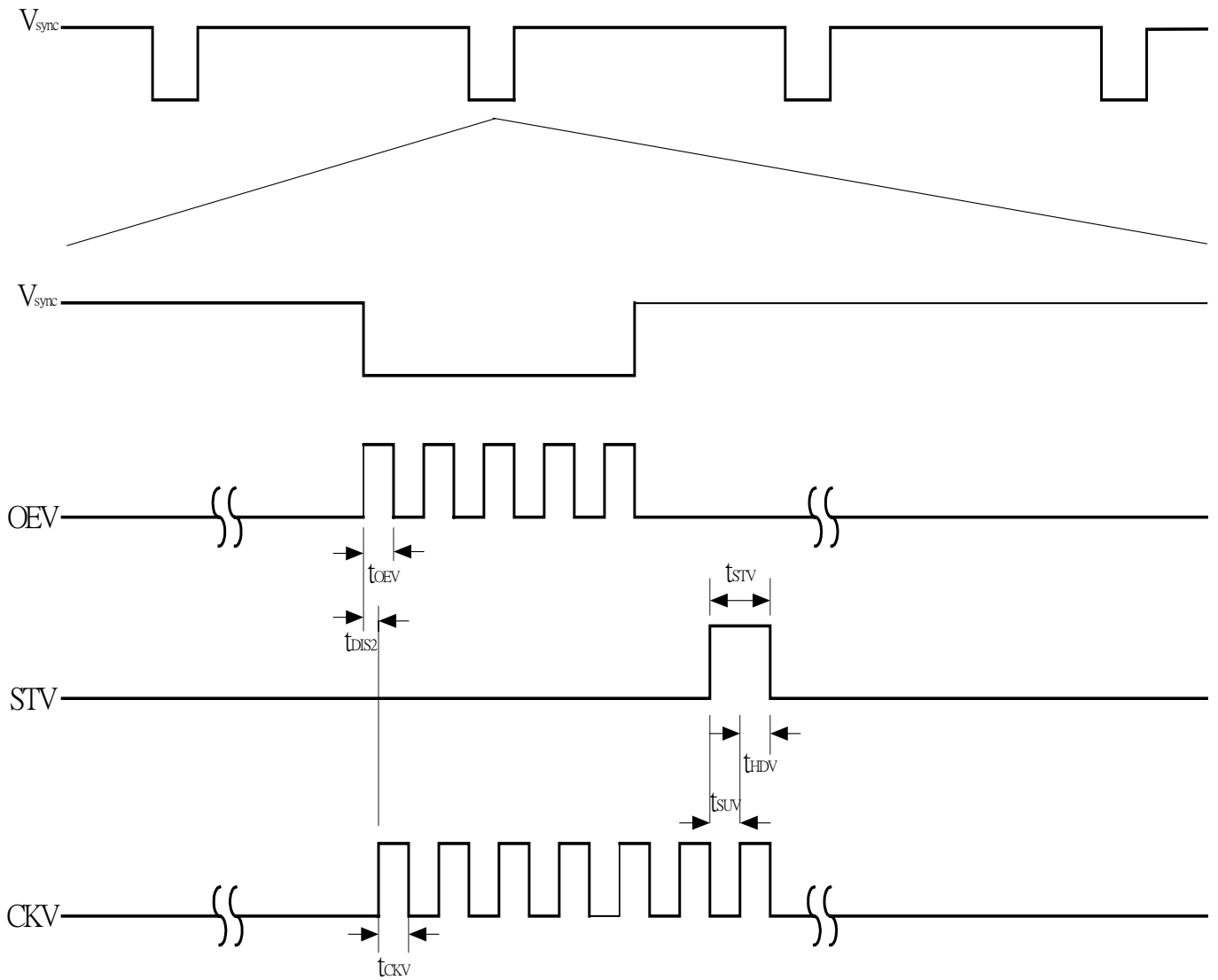

Fig.5 Vertical timing

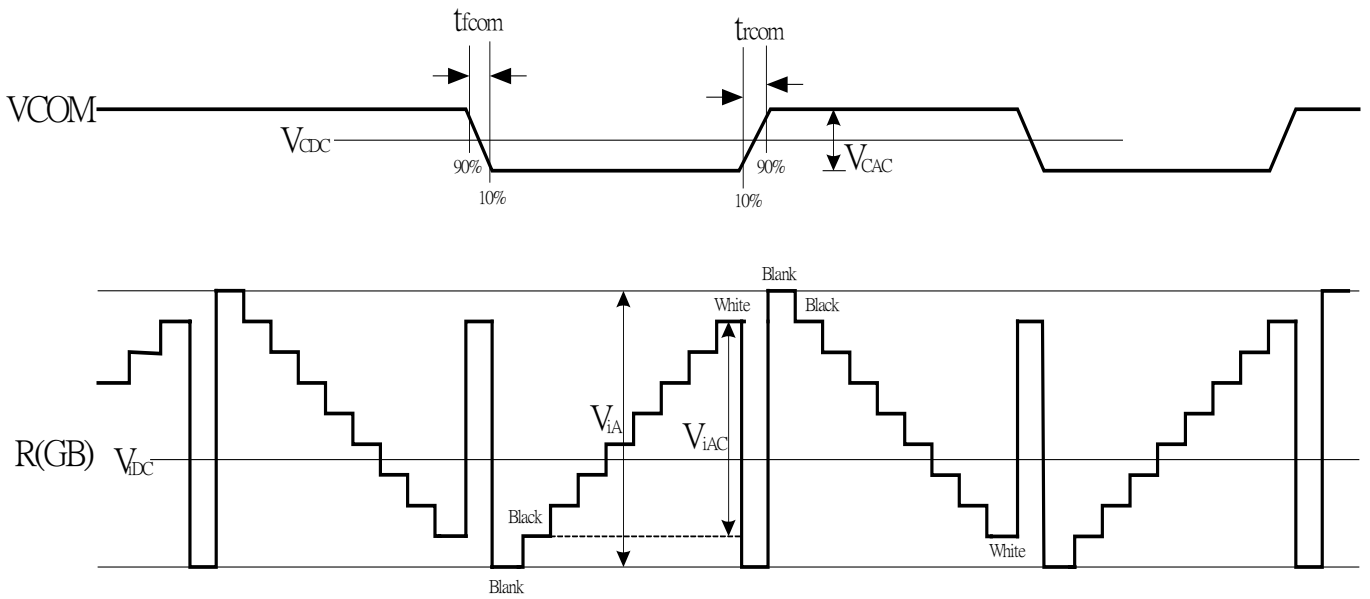
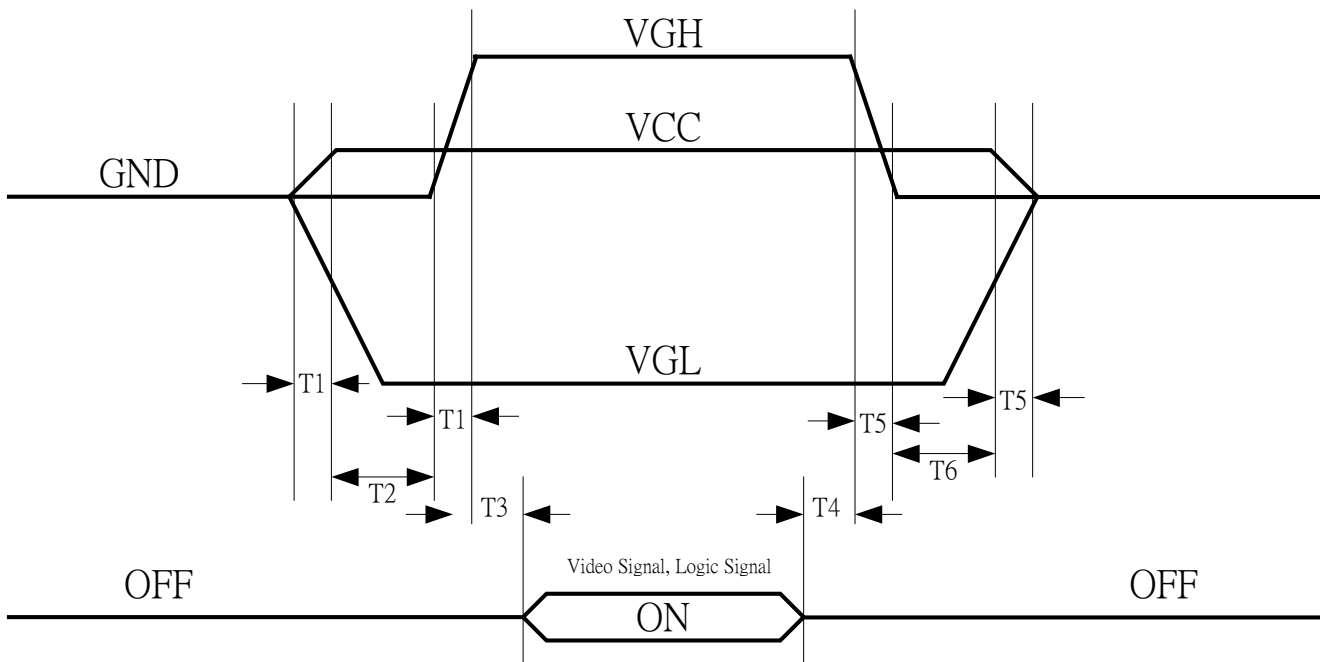

Fig.6 Relation of V_{GL} and V_{COM}



- $T1 \leq 15\text{ms}$ (From $10\% \cdot V_{CC}$ to $90\% \cdot V_{CC}$, when V_{CC} is Low to High) ;
- $T2 \leq 10\text{ms}$ (From $90\% \cdot V_{CC}$ to $10\% \cdot V_{GH}$, when V_{CC} is Low to High) ;
- $T3 \leq 10\text{ms}$ (From $90\% \cdot V_{GH}$ to Video Signal , when V_{GH} is Low to High) ;
- $T4 \leq 10\text{ms}$ (From Video signal to $90\% \cdot V_{GH}$, when V_{GH} is High to Low) ;
- $T5 \leq 20\text{ms}$ (From $90\% \cdot V_{CC}$ to $10\% \cdot V_{CC}$, when V_{CC} is High to Low) ;
- $T6 \leq 10\text{ms}$ (From $10\% \cdot V_{GH}$ to $90\% \cdot V_{CC}$, when V_{CC} is Low to High) ;

Fig 7 Power Sequence

8. HANDLING PRECAUTIONS FOR TFT-LCD MODULE

Please pay attention to the followings in handling- TFT-LCD products;

(A) ASSEMBLY PRECAUTION

- (1) Please use the mounting hole on the module side in installing and do not beading or wrenching LCD in assembling. And please do not drop, bend or twist LCD module in handling.
- (2) Please design display housing in accordance with the following guide lines.
 - (2.1) Housing case must be destined carefully so as not to put stresses on LCD all sides and not to wrench module. The stresses may cause non-uniformity even if there is no non-uniformity statically.
 - (2.2) Keep sufficient clearance between LCD module back surface and housing when the LCD module is mounted. Approximately 1.0 mm of the clearance in the design is recommended taking into account the tolerance of LCD module thickness and mounting structure height on the housing.
 - (2.3) When some parts, such as, FPC cable and ferrite plate, are installed underneath the LCD module, still sufficient clearance is required, such as 0.5mm. This clearance is, especially, to be reconsidered when the additional parts are implemented for EMI countermeasure.
 - (2.4) Design the inverter location and connector position carefully so as not to give stress to lamp cable, or not to interface the LCD module by the lamp cable.
 - (2.5) Keep sufficient clearance between LCD module and the others parts, such as inverter and speaker so as not to interface the LCD module. Approximately 1.0mm of the clearance in the design is recommended.
- (3) Please do not push or scratch LCD panel surface with any-thing hard. And do not soil LCD panel surface by touching with bare hands. (Polarizer film, surface of LCD panel is easy to be flawed.)
- (4) Please do not press any parts on the rear side such as source TCP, gate TCP, control circuit board and FPCs during handling LCD module. If pressing rear part is unavoidable, handle the LCD module with care not to damage them.
- (5) Please wipe out LCD panel surface with absorbent cotton or soft cloth in case of it being soiled.
- (6) Please wipe out drops of adhesives like saliva and water on LCD panel surface immediately. They might damage to cause panel surface variation and color change.
- (7) Please do not take a LCD module to pieces and reconstruct it. Resolving and reconstructing modules may cause them not to work well.
- (8) Please do not touch metal frames with bare hands and soiled gloves. A color change of the metal frames can happen during a long preservation of soiled LCD modules.
- (9) Please pay attention to handling lead wire of backlight so that it is not tugged in connecting wit inverter.

(B) OPERATING PRECAUTIONS

- (1) Please be sure to turn off the power supply before connecting and disconnecting signal input cable.
- (2) Please do not change variable resistance settings in LCD module. They are adjusted to the most suitable value. If they are changed, it might happen LCD does not satisfy the characteristics specification.
- (3) Please consider that LCD backlight takes longer time to become stable of radiation characteristics in low temperature than in room temperature.
- (4) A condensation might happen on the surface and inside of LCD module in case of sudden charge of ambient temperature.
- (5) Please pay attention to displaying the same pattern for very long time. Image might stick on

LCD. If then, time going on can make LCD work well.

- (6) Please obey the same caution descriptions as ones that need to pay attention to ordinary electronic parts.

(C) PRECAUTIONS WITH ELECTROSTATICS

- (1) This LCD module use CMOS-IC on circuit board and TFT-LCD panel, and so it is easy to be affected by electrostatics. Please be careful with electrostatics by the way of your body connecting to the ground and so on.
- (2) Please remove protection film very slowly on the surface of LCD module to prevent from electrostatics occurrence.

(D) STORAGE PRECAUTIONS

- (1) When you store LCDs for a long time, it is recommended to keep the temperature between 0°C-40°C without the exposure of sunlight and to keep the humidity less than 90%RH.
- (2) Please do not leave the LCDs in the environment of high humidity and high temperature such as 60°C 90%RH.
- (3) Please do not leave the LCDs in the environment of low temperature; below -20°C.

(E) SAFETY PRECAUTIONS

- (1) When you waste LCDs, it is recommended to crush damaged or unnecessary LCDs into pieces and wash them off with solvents such as acetone and ethanol, which should later be burned.
- (2) If any liquid leaks out of a damaged-glass cell and comes in contact with the hands, wash off thoroughly with soap and water.

(F) OTHERS

- (1) A strong incident light into LCD panel might cause display characteristics' changing inferior because of polarizer film, color filter, and other materials becoming inferior. Please do not expose LCD module direct sunlight and strong UV rays.
- (2) Please pay attention to a panel side of LCD module not to contact with other materials in preserving it alone.
- (3) For the packaging box, please pay attention to the followings:
 - (3.1) Packaging box and inner case for LCD are designed to protect the LCDs from the damage or scratching during transportation. Please do not open except picking LCDs up from the box.
 - (3.2) Please do not pile them up more than 5 boxes. (They are not designed so.) And please do not turn over.
 - (3.3) Please handle packaging box with care not to give them sudden shock and vibrations. And also please do not throw them up.
 - (3.4) Packing box and inner case for LCDs are made of cardboard. So please pay attention not to get them wet. (Such like keeping them in high humidity or wet place can occur getting them wet.)