



# Chunghwa Picture Tubes, Ltd.

## Product Specification

To : EECHAIN

Date : 070518

**TFT LCD**

**CLAA057VA01CT**

ACCEPTED BY : (V0.4)

Tentative

APPROVED BY	CHECKED BY	PREPARED BY
張聖暉	李家銘	羅世奎

Prepared by :

Product Planning Management Division  
Small & Medium TFT Product Business Unit  
**CHUNGHWA PICTURE TUBES, LTD.**

1127 Hopin Rd., Padeh, Taoyuan, Taiwan 334, R.O.C.  
TEL: +886-3-3675151 FAX: +886-3-377-3858

Doc.No:	SPEC_CLAA057VA01CT_V0.4_070518	Issue Date:	2007/04/19
---------	--------------------------------	-------------	------------



## CONTENTS

<b>1. OVERVIEW</b> .....	<b>4</b>
<b>2. ABSOLUTE MAXIMUM RATINGS</b> .....	<b>5</b>
<b>3. ELECTRICAL CHARACTERISTICS</b> .....	<b>6</b>
3.1TFT LCD .....	6
3.2TFT-LCD current consumption.....	6
3.3 Power 、Signal sequence.....	7
<b>4. INTERFACE CONNECTION</b> .....	<b>8</b>
<b>5. INPUT SIGNAL(DE ONLY MODE)</b> .....	<b>10</b>
5.1 Timing Specification .....	10
5.2 Timing sequence(Timing chart).....	11
5.3 Color Data Assignment.....	13
<b>6. CHARACTERISTIC OF TOUCH PANEL</b> .....	<b>14</b>
6.1 Basis characteristic .....	14
6.2 Design guideline for Touch-Panel.....	14
6.3 Circuit Diagram .....	15
<b>7. BLOCK DIAGRAM</b> .....	<b>16</b>
<b>8. MECHANICAL DIMENSION</b> .....	<b>17</b>
8.1 Front Side .....	17
8.2 Rear Side .....	17
<b>9. OPTICAL CHARACTERISTICS</b> .....	<b>18</b>
<b>10. RELIABILITY TEST</b> .....	<b>21</b>
10-1. Temperature and humidity.....	21
10-2. Shock and Vibration .....	21
10-3. Judgment standard .....	21

## 1. OVERVIEW

CLAA057VAO1CT is 5.7" color TFT-LCD(Thin Film Transistor Liquid Crystal Display)module composed of LCD panel,driver ICs,control circuit,and LED backlight.

The 14.52cm(5.7") screen produces a high resolution image that is composed of 640×480 pixel elements in a stripe arrangement.Display 262K colors by 6 Bit R.G.B signal input.Use 3.3 Voltage to drive the power of LCD system,and 5 Voltage to drive the LED back light.

General specifications are summarized in the following table:

ITEM	SPECIFICATION
Panel Size	5.7 inch(panel diagonal)
Display Area (mm)	116.16(W)×87.12(H)
Number of Pixels	640×3(H)×480(V)
Pixel Pitch (mm)	0.1815(H)×0.1815(V)
Color Pixel Arrangement	RGB vertical stripe
Display Mode	Normally white
Number of colors	262,144
Viewing Direction	6 o'clock
Response Time (Tr+Tf)	30ms
Brightness(cd/m <sup>2</sup> )	180nit(typ)
NTSC ratio	50%
Viewing Angle(BL on,CR ≥ 10)	140 degree(H) · 100degree(V)
Electrical Interface(data)	TTL
Power consumption(W)	2W
Outline Dimension(in mm)	127(W)×100(H)×7.85(D)
Weight(g)	~132g
BL unit	LED
Surface Treatment	Anti-Glare · Hardness:3H
Type of touch screen	4 Wire resistance type

## 2. ABSOLUTE MAXIMUM RATINGS

Item	Symbol	Min.	Max.	Unit	Note
Power Supply Voltage	Vcc	-0.5	5.0	V	
Signal Input Voltage	DCLK,DE,R0,G0 ,B0~R5,G5,B5	-0.5	Vcc + 0.5	V	
Static Electricity	VESDc	-200	+200	V	*2)
	VESDm	-15K	+15K	V	
ICC Rush Current	IRUSH	-	1	A	*3)
Operation Temperature	T <sub>op</sub>	-30	85	°C	*1)
Storage Temperature	T <sub>stg</sub>	-40	95	°C	*1)

Remarks :

\*1) If users use the product out off the environment operation range ( temperature and humidity ) ,it will concern for visual quality.

\*2) Test Condition: IEC 61000-4-2 ,

VESDc : Contact discharge to input connector

VESDm : Contact discharge to module

\*3) The input pulse-current measurement system as below :

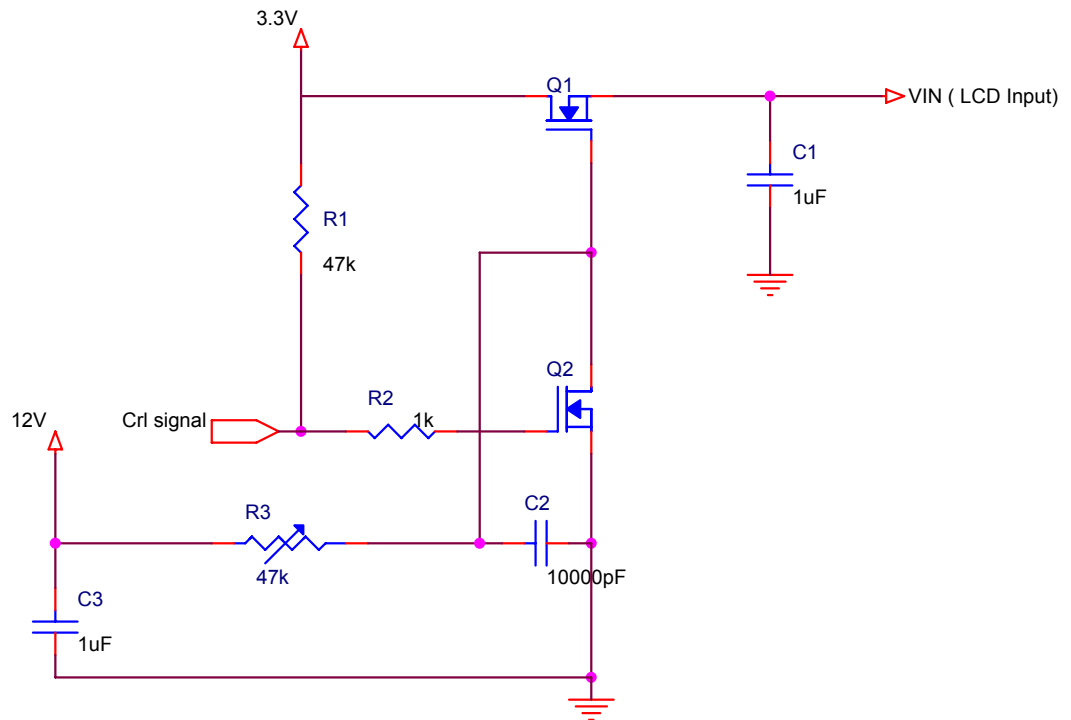

Control signal:High(+3.3V)→Low(GND)

Supply Voltage of rising time should be from R3 and C2 tune to 550 us.

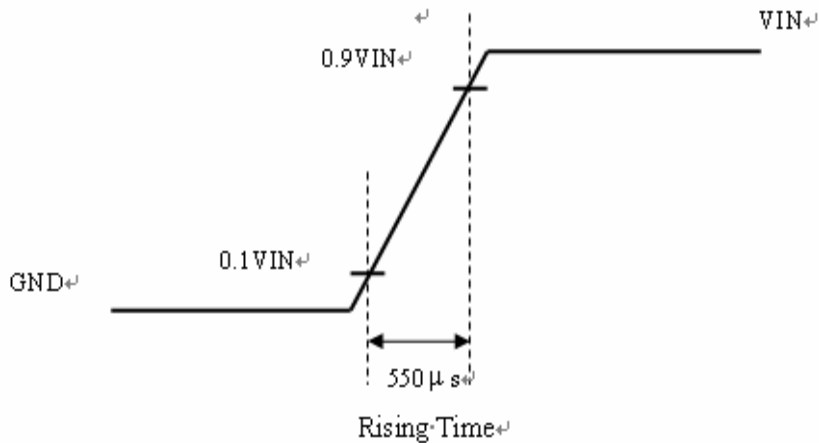

### 3. ELECTRICAL CHARACTERISTICS

#### 3.1TFT LCD

Ta=25°C

Item	Symbol	Min.	Typ	Max.	Unit	Note
Power Supply Voltage For LCD	V <sub>CC</sub>	3.0	3.3	3.6	V	*1)
Power Supply Voltage For LED	V <sub>LED</sub>	4.5	5	5.5	V	
Logic Input Voltage	V <sub>IH</sub>	V <sub>CC</sub> *0.7	--	V <sub>CC</sub>	V	
	V <sub>IL</sub>	0	--	V <sub>CC</sub> *0.3	V	
ADJ Input Voltage	Threshold Voltage(high)	V <sub>IH</sub>	3.0	--	3.3	V
	Threshold Voltage(low)	V <sub>IL</sub>	GND	--	0.3	V

Remarks :

\*1) VCC –dip condition:

When  $2.7V \leq V_{CC} < 3.0V$ ,  $t_d \leq 10ms$ .

$V_{CC} > 3.0V$ , VCC-dip condition should be same as VCC-turn-on condition.

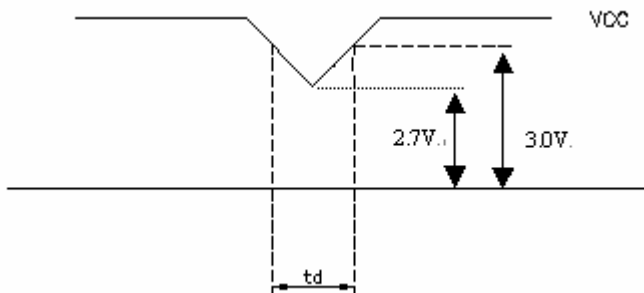

#### 3.2TFT-LCD current consumption

Item	Symbol	Min.	Typ	Max.	Unit	Note
LCD power current	I <sub>CC</sub>	--	140	190	mA	*1)
LED power current	I <sub>LED</sub>		300	350	mA	*2)

\*1) Typical: Under 64 gray pattern  
Maximum: Under black pattern

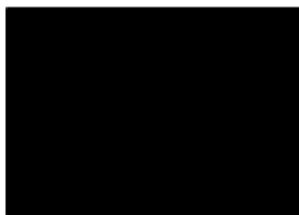

(a) 64-Gray Pattern (b) Black Pattern

\*2) Typical: When V<sub>LED</sub> is 5.0V  
Maximum: When V<sub>LED</sub> is 4.5V

3.3 Power · Signal sequence

- $t1 \leq 10\text{ms}$        $1 \text{ sec} \leq t5$
- $50\text{ms} \leq t2$        $200\text{ms} \leq t6$
- $0 < t3 \leq 50\text{ms}$        $200\text{ms} \leq t7$
- $0 < t4 \leq 10\text{ms}$

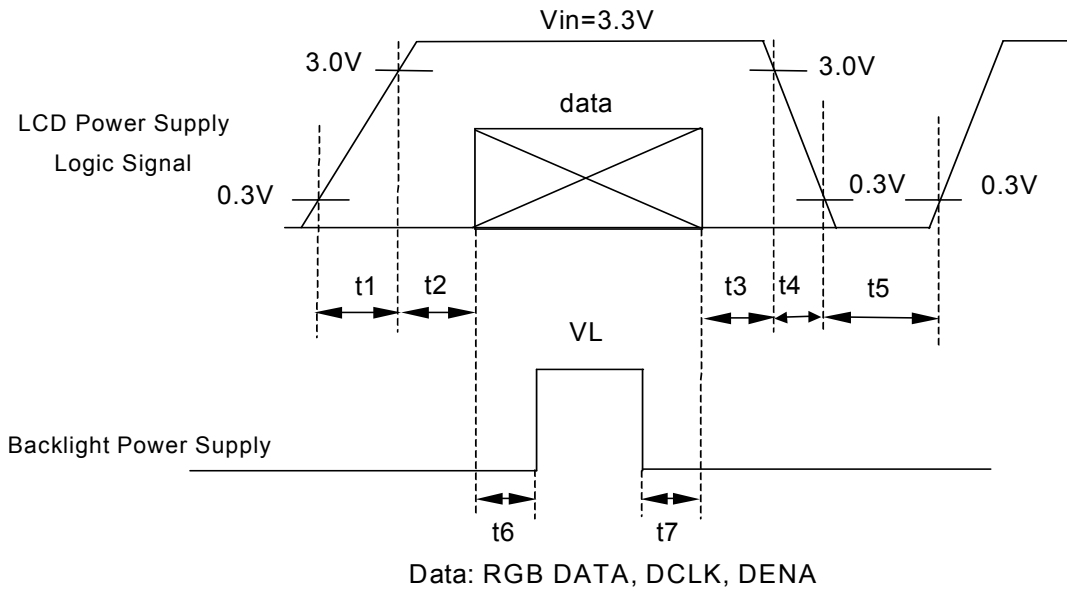

## 4. INTERFACE CONNECTION

CN1 : Starconn 089N40-000R00-G2

Pin NO.	SYMBOL	DESCRIPTION
1	U/D	Up / Down Display Control
2	DMS	DE / SYNC Mode Selection
3	Hsync	Horizontal SYNC.
4	V <sub>LED</sub>	Power Supply for LED
5	V <sub>LED</sub>	Power Supply for LED
6	V <sub>LED</sub>	Power Supply for LED
7	V <sub>CC</sub>	Power Supply for LCD
8	Vsync	Vertical SYNC.
9	DE	Data Enable
10	X2	TSP control (Left)
11	Y1	TSP control (Up)
12	ADJ	Adjust for LED brightness
13	B5	Blue Data 5 (MSB)
14	B4	Blue Data 4
15	B3	Blue Data 3
16	V <sub>SS</sub>	Power Ground
17	B2	Blue Data 2
18	B1	Blue Data 1
19	B0	Blue Data 0 (LSB)
20	V <sub>SS</sub>	Power Ground
21	G5	Green Data 5 (MSB)
22	G4	Green Data 4
23	G3	Green Data 3
24	V <sub>SS</sub>	Power Ground
25	G2	Green Data 2
26	G1	Green Data 1
27	G0	Green Data 0 (LSB)
28	V <sub>SS</sub>	Power Ground
29	R5	Red Data 5 (MSB)
30	R4	Red Data 4
31	R3	Red Data 3
32	V <sub>SS</sub>	Power Ground
33	R2	Red Data 2
34	R1	Red Data 1
35	R0	Red Data 0 (LSB)
36	X1	TSP control (Right)
37	Y2	TSP control (Down)
38	DCLK	Clock Signals
39	V <sub>SS</sub>	Power Ground
40	L/R	Left / Right Display Control

Remarks :

1).ADJ adjust brightness to control Pin , Pulse duty the bigger the brighter.

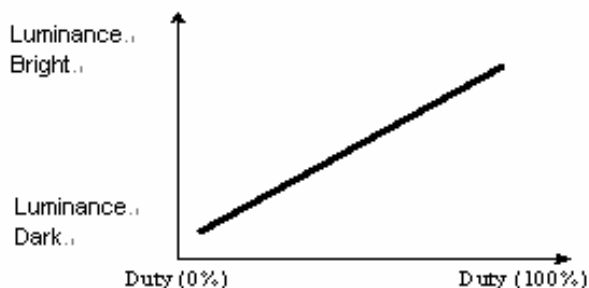



2) ADJ signal = 0~3.3V , operation frequency: 20±10KHZ

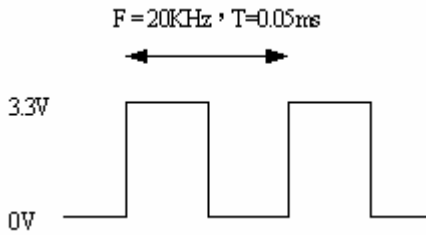

3) VSS Pin must ground contact , can not be floating.

4) U/D and L/R are controlled function

L/R	U/D	Function
1	0	Normally display
0	0	Left and Right opposite
1	1	Up and Down opposite
0	1	Left and Right opposite , Up and Down opposite

5) DMS ( Selection DE / SYNC mode )

DMS	Function
1	DE Mode
0	SYNC Mode

## 5. INPUT SIGNAL(DE ONLY MODE)

### 5.1 Timing Specification

characteristics		SYMBOL	MIN.	TYP.	MAX.	UNIT	NOTE
DE MODE	Dot Clock	$F_{OSC}$	23	25	30	MHz	
	Horizontal Period	$T_H$	750	800	900	$T_{OSC}$	
	Horizontal Valid	$T_{HV}$	640				
	Horizontal Blank	$T_{HBK}$	110	160	260		
	Vertical Period	$T_{VP}$	515	525	560	$T_H$	
	Vertical Valid	$T_{VV}$	480				
	Vertical Blank	$T_{VBK}$	35	45	80		
	Vertical Frequency	$F_V$	55	60	65	Hz	
SYNC MODE	Horizontal Period	$T_H$	750	800	900	$T_{OSC}$	
	Horizontal Pulse Width	$T_{HS}$	1	1	1		
	Horizontal Pulse Width + Back Proch	$T_{HPWB}$	46	46	46		
	Horizontal Front Proch	$T_{HF}$	64	114	214		
	Horizontal Valid	$T_{HV}$	640			$T_H$	
	Vertical Period	$T_{VP}$	515	525	560		
	Vertical Pulse Width	$T_{VS}$	1	1	1		
	Vertical Pulse Width + Back Proch	$T_{VPWB}$	34	34	34		
	Vertical Front Proch	$T_{VF}$	1	11	46		
	Vertical Valid	$T_{VV}$	480				
	Vertical Frequency	$F_V$	55	60	65		Hz

5.2 Timing sequence(Timing chart)

Horizontal Timing Sequence

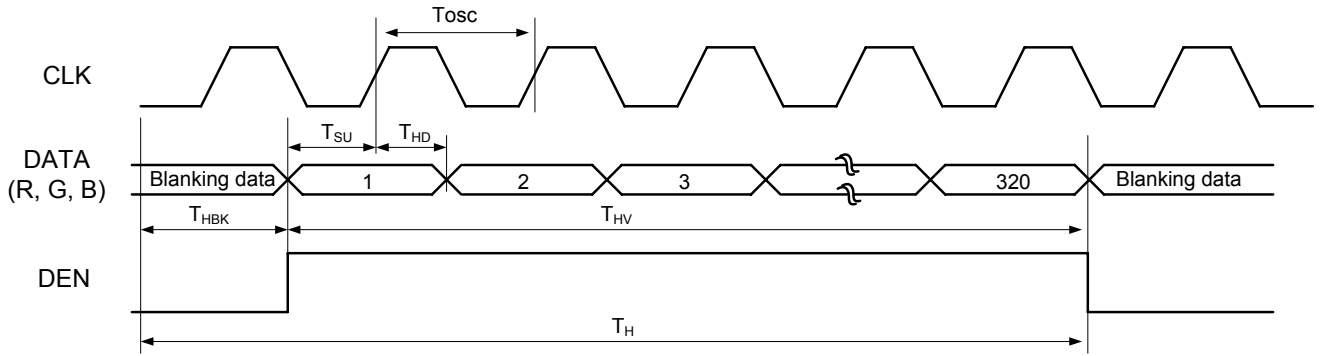

Vertical Timing Sequence

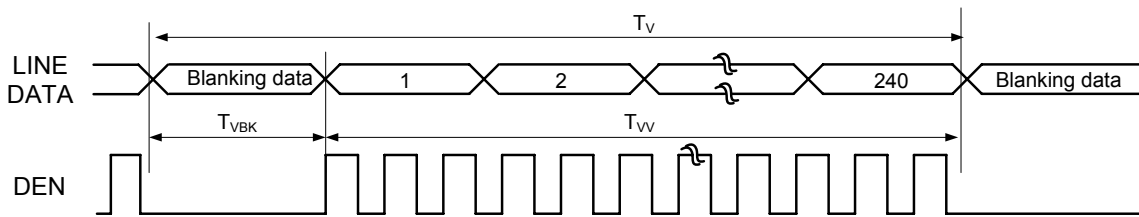

DE mode Timing

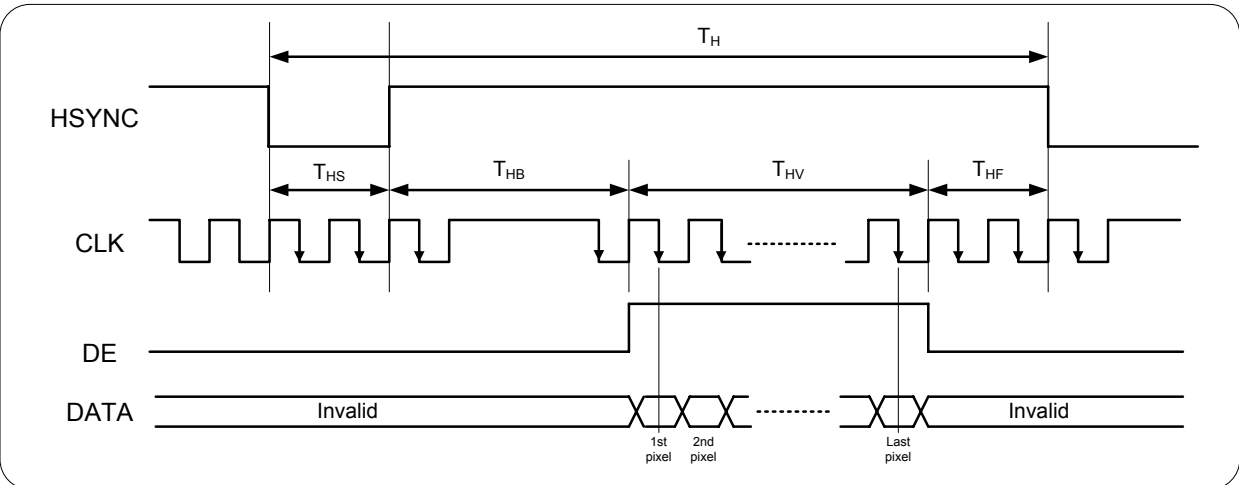
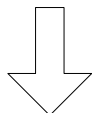
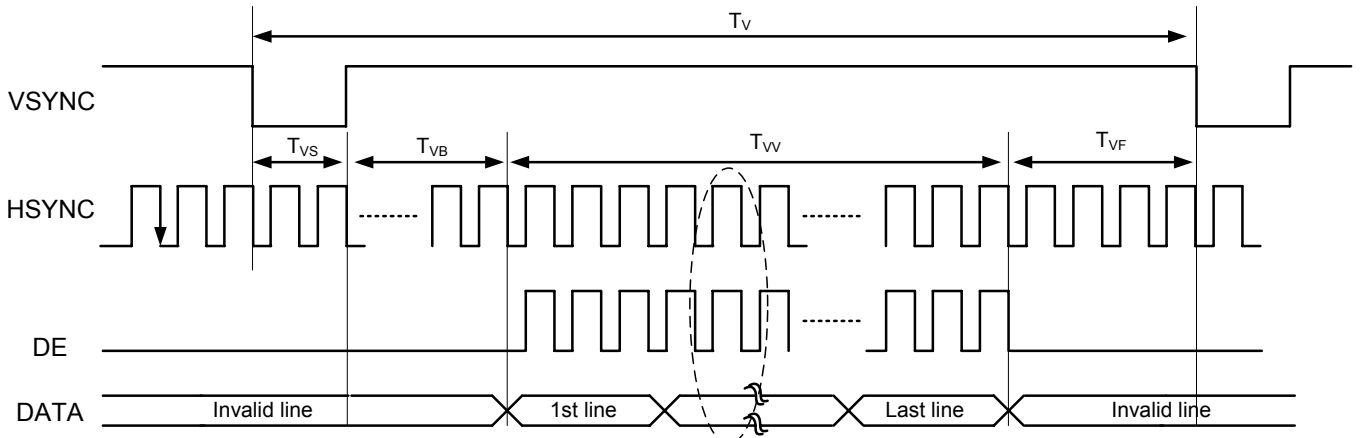

Sync mode Timing

5.3 Color Data Assignment

COLOR	INPUT	R DATA						G DATA						B DATA					
		R5	R4	R3	R2	R1	R0	G5	G4	G3	G2	G1	G0	B5	B4	B3	B2	B1	B0
	DATA	MSB					LSB	MSB					LSB	MSB					LSB
	BLACK	0	0	0	0	0	0	0	0	0	0	0	0	0	0	0	0	0	0
	RED(63)	1	1	1	1	1	1	0	0	0	0	0	0	0	0	0	0	0	0
BASIC	GREEN(63)	0	0	0	0	0	0	1	1	1	1	1	1	0	0	0	0	0	0
COLOR	BLUE(63)	0	0	0	0	0	0	0	0	0	0	0	0	1	1	1	1	1	1
	CYAN	0	0	0	0	0	0	1	1	1	1	1	1	1	1	1	1	1	1
	MAGENTA	1	1	1	1	1	1	0	0	0	0	0	0	1	1	1	1	1	1
	YELLOW	1	1	1	1	1	1	1	1	1	1	1	1	0	0	0	0	0	0
	WHITE	1	1	1	1	1	1	1	1	1	1	1	1	1	1	1	1	1	1
	RED(0)	0	0	0	0	0	0	0	0	0	0	0	0	0	0	0	0	0	0
	RED(1)	0	0	0	0	0	1	0	0	0	0	0	0	0	0	0	0	0	0
	RED(2)	0	0	0	0	1	0	0	0	0	0	0	0	0	0	0	0	0	0
RED																			
	RED(62)	1	1	1	1	1	0	0	0	0	0	0	0	0	0	0	0	0	0
	RED(63)	1	1	1	1	1	1	0	0	0	0	0	0	0	0	0	0	0	0
	GREEN(0)	0	0	0	0	0	0	0	0	0	0	0	0	0	0	0	0	0	0
	GREEN(1)	0	0	0	0	0	0	0	0	0	0	0	1	0	0	0	0	0	0
	GREEN(2)	0	0	0	0	0	0	0	0	0	0	1	0	0	0	0	0	0	0
GREEN																			
	GREEN(62)	0	0	0	0	0	0	1	1	1	1	1	0	0	0	0	0	0	0
	GREEN(63)	0	0	0	0	0	0	1	1	1	1	1	1	0	0	0	0	0	0
	BLUE(0)	0	0	0	0	0	0	0	0	0	0	0	0	0	0	0	0	0	0
	BLUE(1)	0	0	0	0	0	0	0	0	0	0	0	0	0	0	0	0	0	1
	BLUE(2)	0	0	0	0	0	0	0	0	0	0	0	0	0	0	0	0	1	0
BLUE																			
	BLUE(62)	0	0	0	0	0	0	0	0	0	0	0	0	1	1	1	1	1	0
	BLUE(63)	0	0	0	0	0	0	0	0	0	0	0	0	1	1	1	1	1	1

Remarks :

(1) Definition of Gray Scale

color(n) : n is series of Gray Scale

The more n value is, the bright Gray Scale.

(2)Data:1-High,0-Low

## 6. CHARACTERISTIC OF TOUCH PANEL

### 6.1 Basis characteristic

Item	Standard	Note
Operating Voltage	3V(Min)/5V(Typ)/7V(Max)	DC
Surface Treatment	Anti-Glare · Hardness : 3H	
Activation Force	< 80gf	Less than 80gf(Typical 25gf) individual with stylus pen (R 0.8mm) or finger (R 8.0mm)
Linearity Force	130 gf	2 Layer(Thickness :0.7mm )
Interface Type	4 Wire Resistive	
Resistance Between Terminals	X(Glass side) : 450~1200Ω Y(Film side) : 150~700Ω	At the connector
Linearity	X(Glass side) : ≤ 1.5% Y(Film side) : ≤ 1.5%	Testing interval is 2mm with load 120g
Insulation Resistance	Min. 20MΩ	At DC 25V

### 6.2 Design guideline for Touch-Panel

- The Housing Cushion on touch-panel must be set at outside of T.P's view-area .
- The Cushion material must be elastic material.
- The housing must avoid to touch the T.P
- To combine, the housing should not be stuck on T.P.
- Example of housing design :

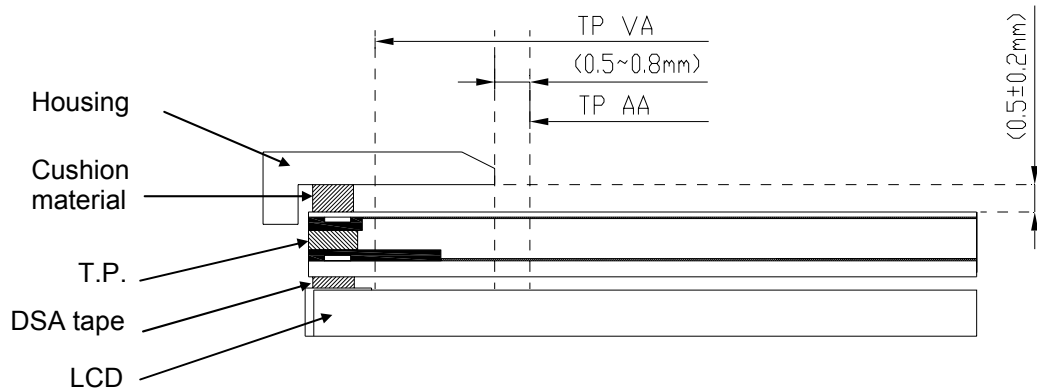

## 6.3 Circuit Diagram

PIN No.	Assignment
1	YU
2	XR
3	YD
4	XL

X:Glass electrode  
Y:Film electrode

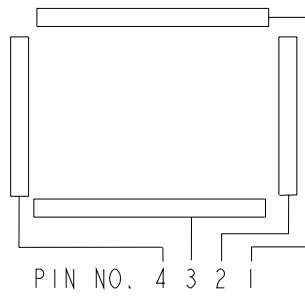

### 7. BLOCK DIAGRAM

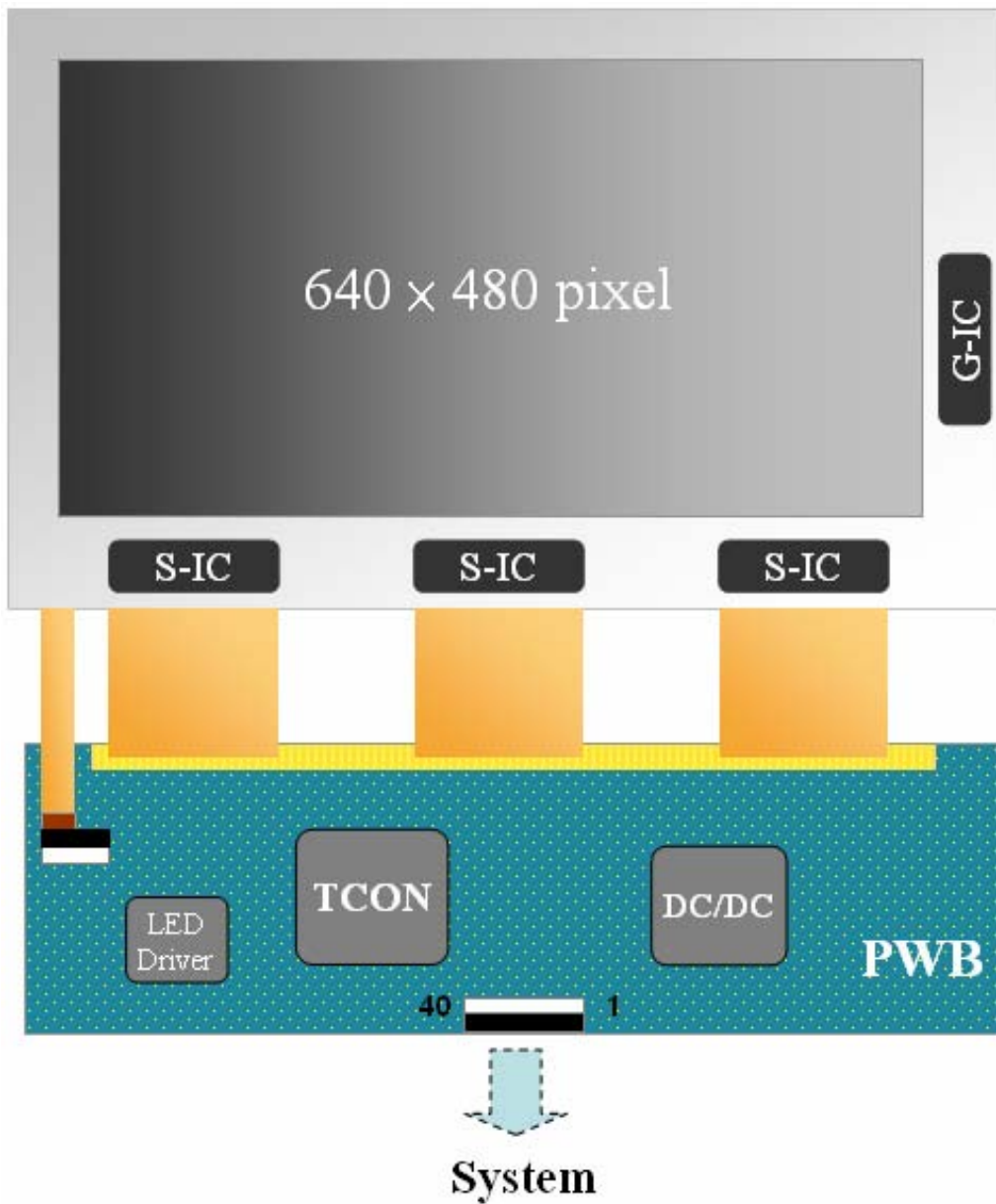



### 8. MECHANICAL DIMENSION

#### 8.1 Front Side

[Unit : mm]

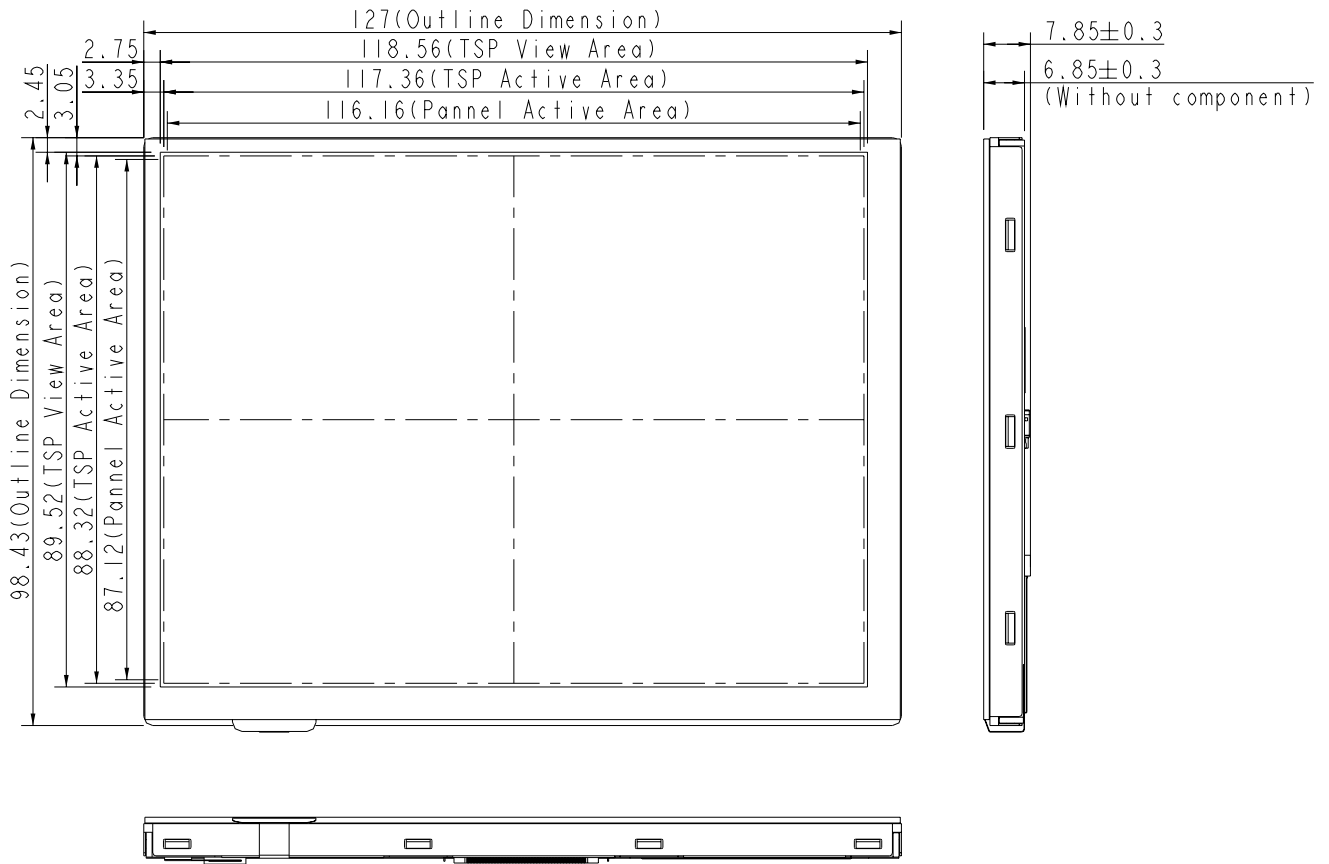

#### 8.2 Rear Side

[Unit : mm]

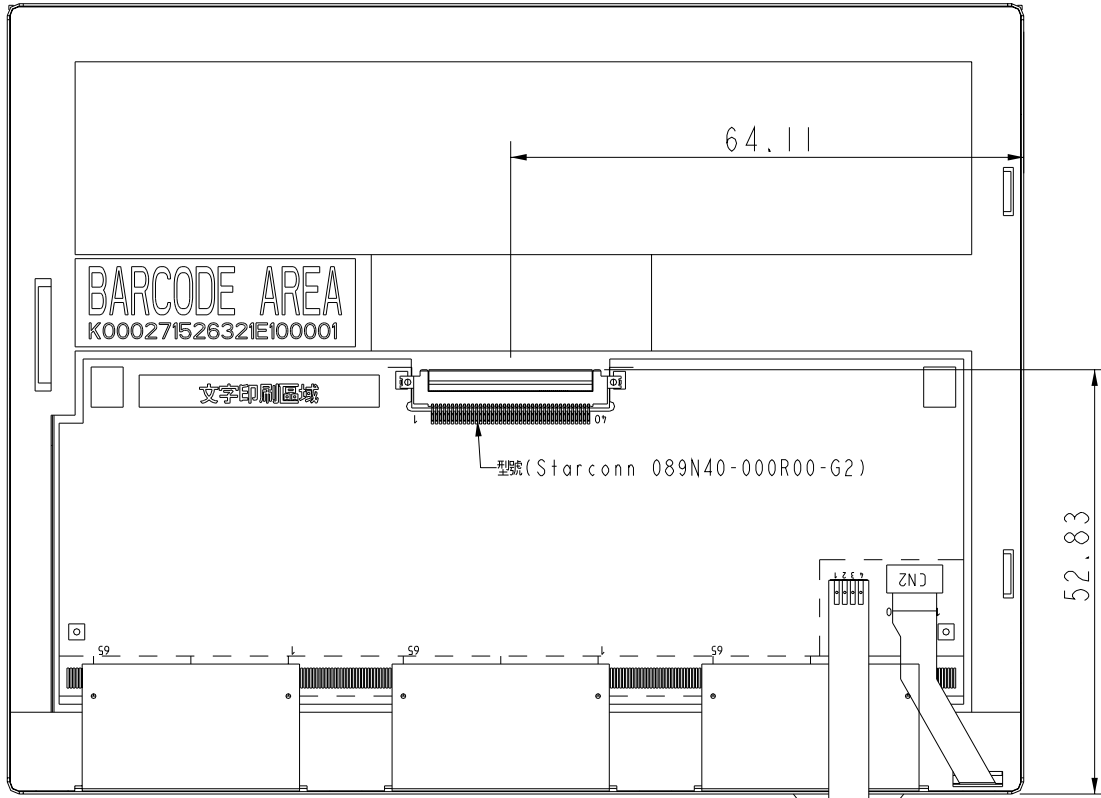

Remark : Un-indication tolerance is  $\pm 0.3\text{mm}$

## 9. OPTICAL CHARACTERISTICS

ITEM	SYMBOL	CONDITION	MIN.	TYP.	MAX.	UNIT	Remarks	
Constrast Ratio	CR	Point-5	200	300	--	--	*1)*2)*3)	
Luminance	Lw	Point-5	160	180	--	cd/m <sup>2</sup>	*1)*3)	
Luminance Uniformity	ΔL		70	80	--	%	*1)*3)	
Response Time (White - Black)	Tr+ Tf	Point-5	--	30	50	ms	*1)*3)*5)	
Viewing Angle	Horizontal	$\phi$	CR ≥ 10 Point-5	120	140	--	°	*1)*2)*4)
	Vertical	$\theta$		80	100	--	°	*1)*2)*4)
Color Coordinate	White	Wx Wy	Point-5	0.273 0.289	0.313 0.329	0.353 0.369	--	*1)*3)
	Red	Rx Ry		TBD	TBD	TBD		
	Green	Gx Gy		TBD	TBD	TBD		
	Blue	Bx By		TBD	TBD	TBD		

Remarks :

\*1)Measure condition : 25°C±2°C , 60±10%RH , under10 Lux in the dark room.BM-5A (TOPCON) , viewing angle2° , VCC=3.3V , V<sub>LED</sub>=5V.

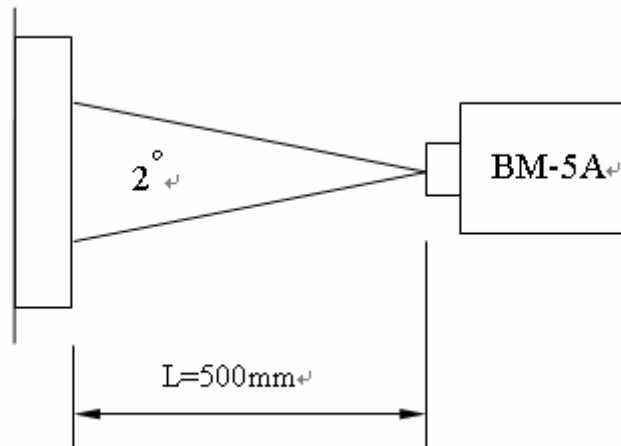

\*2) Definition of contrast ratio :

Contrast Ratio (CR)= (White) Luminance of ON ÷ (Black) Luminance of OFF

\*3) Definition of luminance :

Measure white luminance on the point 5 as figure8-1  
 Definition of Luminance Uniformity:  
 Measure white luminance on the point1~9 as figure8-1  
 $\Delta L = [L(\text{MIN})/L(\text{MAX})] \times 100\%$

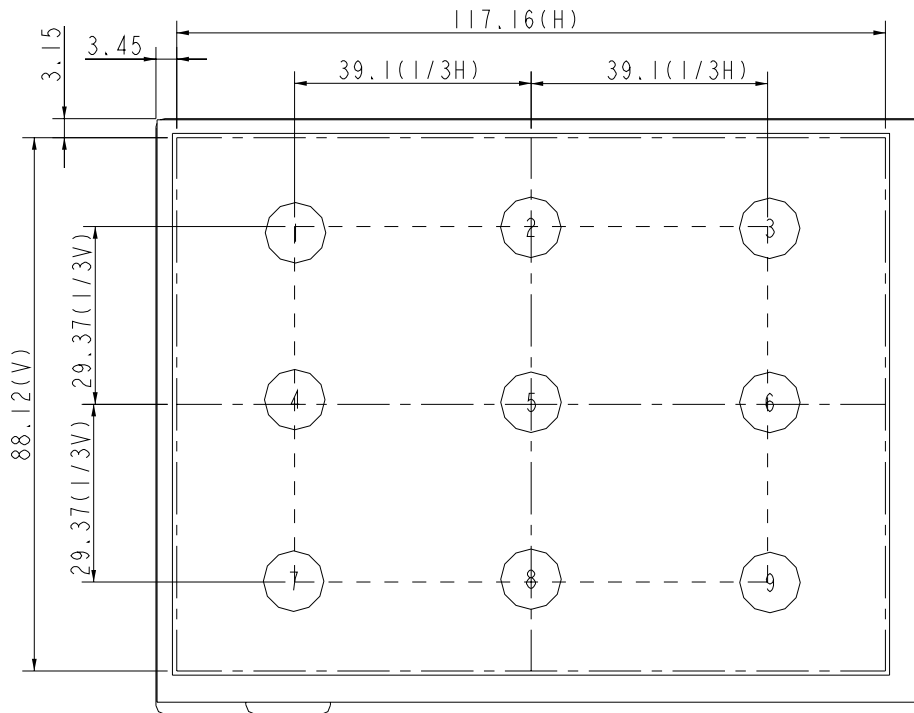

Fig8-1 Measuring point

\*4) Definition of Viewing Angle( $\theta, \psi$ ), refer to Fig8-2 as below :

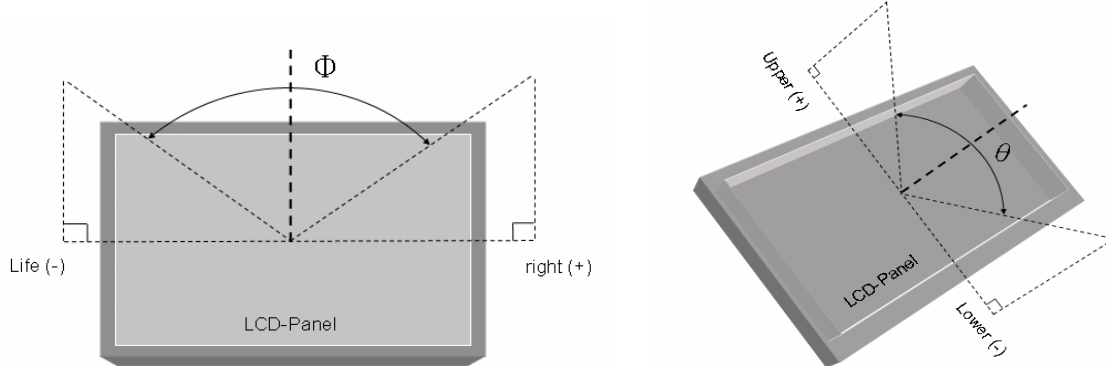

Fig8-2 Definition of Viewing Angle

\*5) Definition of Response Time.(White-Black)

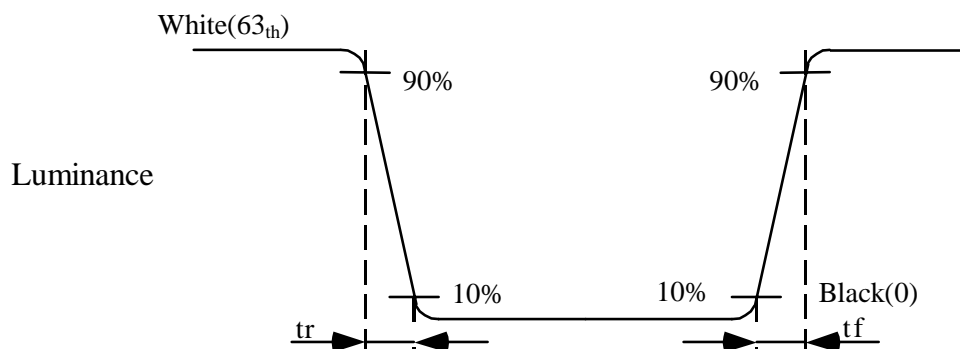

Fig8-3 Definition of Response Time(White-Black)

## 10. RELIABILITY TEST

### 10-1. Temperature and humidity

TEST ITEMS	CONDITIONS
High Temperature Operation	85°C , 240H
High Temperature Storage	95°C , 240H
High Temperature High Humidity Operation	60°C , 90%RH , 240H
Low Temperature Operation	-30°C , 240H, Backlight unit always turn on
Low Temperature Storage	-40°C , 240H
Thermal Shock	-30°C ( 0.5Hr ) ~ 85°C(0.5Hr) 200 cycles

### 10-2. Shock and Vibration

TEST ITEMS	CONDITIONS
Shock (Non-operation)	<ul style="list-style-type: none"> <li>● Shock level:980m/s<sup>2</sup>(equal to 100G)</li> <li>● Waveform:half sinusoidal wave,6ms.</li> <li>● Number of shocks:one shock input in each direction of three mutually perpendicular axes for a total of three shock inputs.</li> </ul>
Vibration (Non-operation)	<ul style="list-style-type: none"> <li>● Frequency range:8~33.3Hz</li> <li>● Stoke:1.3mm</li> <li>● Vibration:sinusodial wave,perpendicularaxis(both x,y,z axis:2Hrs).</li> <li>● Sweep:2.9G,33.3Hz-400Hz</li> <li>● Cycle:15min</li> </ul>

### 10-3. Judgment standard

The Judgment of the above test should be made as follow:

Pass:Normal display image with no obvious non-uniformity and no line defect.Partial trasformation of the module parts should be ignored.

Fail:No display image,obvious non-uniformity,or line defect.