



Chunghwa Picture Tubes, Ltd.

Product Specification

Date : 20060825

TFT LCD
CLAA057VA01

ACCEPTED BY :
TENTATIVE

APPROVED BY	CHECKED BY	PREPARED BY
張聖暉	李家銘	謝明聰

Prepared by :
Small &Medium Product Planning Management Department
Small &Medium Product General Division
CHUNGHWA PICTUER TUBES, LTD.

1127 Hopin Rd., Padeh, Taoyuan, Taiwan 334, R.O.C.
TEL: +886-3-3675151 FAX: +886-3-377-3001

Doc.No:	CLAA057VA01-Ver0-20060825	Issue Date:	2006/07/21
---------	---------------------------	-------------	------------

CONTENTS

1. OVERVIEW	4
2. ABSOLUTE MAXIMUM RATINGS	5
3. ELECTRICAL CHARACTERISTICS	7
3.1TFT LCD	7
3.2TFT-LCD current consumption.....	8
3.3 Power 、Signal sequence.....	8
4. INTERFACE CONNECTION	9
5. INPUT SIGNAL(DE ONLY MODE)	11
5.1 Timing Specification	11
5.2 Timing sequence(Timing chart).....	12
5.3 Color Data Assignment.....	13
6. BLOCK DIAGRAM	14
7. MECHANICAL DIMENSION	15
7.1 Front Side	15
7.2 Rear Side	16
8. OPTICAL CHARACTERISTICS	17
9. RELIABILITY TEST	20
9-1. Temperature and humidity.....	20
9-2. Shock and Vibration.....	20
9-3. Judgment standard	20

1. OVERVIEW

CLAA057VAO1 is 5.7" color TFT-LCD(Thin Film Transistor Liquid Crystal Display)module composed of LCD panel,driver ICs,control circuit,and LED backlight.

The 5.7"screen produces a high resolution image that is composed of 640×480 pixel elements in a stripe arrangement.Display 262K colors by 6 Bit R.G.B signal input.

General specifications are summarized in the following table:

ITEM	SPECIFICATION
Panel Size	5.7 inch(panel diagonal)
Display Area (mm)	116.16(W)×87.12(H)
Number of Pixels	640×3(H)×480(V)
Pixel Pitch (mm)	0.1815(H)×0.1815(V)
Color Pixel Arrangement	RGB vertical stripe
Display Mode	Normally white
Number of colors	262,144
Viewing Direction	6 o'clock
Response Time (Tr+Tf)	30ms
Brightness(cd/m ²)	220nit(typ)
NTSC ratio	50%
Viewing Angle(BL on,CR≥10)	140 degree(H) , 100degree(V)
Electrical Interface(data)	TTL
Power consumption(W)	TBD
Outline Dimension(in mm)	127(W)×100(H)×7(D)
Weight(g)	TBD
BL unit	LED
Surface Treatment	Anti-Glare , Hardness:3H

2. ABSOLUTE MAXIMUM RATINGS

Item	Symbol	Min.	Max.	Unit	Note
Power Supply Voltage	Vcc	-0.5	5.0	V	
Signal Input Voltage	DCLK,DE,R0,G0 ,B0~R5,G5,B5	-0.5	Vcc + 0.5	V	
Static Electricity	VESDc	-200	+200	V	*2)
	VESDm	-15K	+15K	V	
ICC Rush Current	IRUSH	-	1	A	*3)
Operation Temperature	T _{op}	-30	85	°C	*1)
Storage Temperature	T _{stg}	-40	95	°C	*1)
Forward Current (per LED)	I _f	---	30	mA	
Reverse Voltage (per LED)	VR	---	5	V	
Pulse forward current (per LED)	I _{fp}	---	100	mA	*4)

Remarks :

*1) If users use the product out off the environment operation range (temperature and humidity) ,it will concern for visual quality.

*2) Test Condition: IEC 61000-4-2 ,

VESDc : Contact discharge to input connector

VESDm : Contact discharge to module

*3) The input pulse-current measurement system as below :

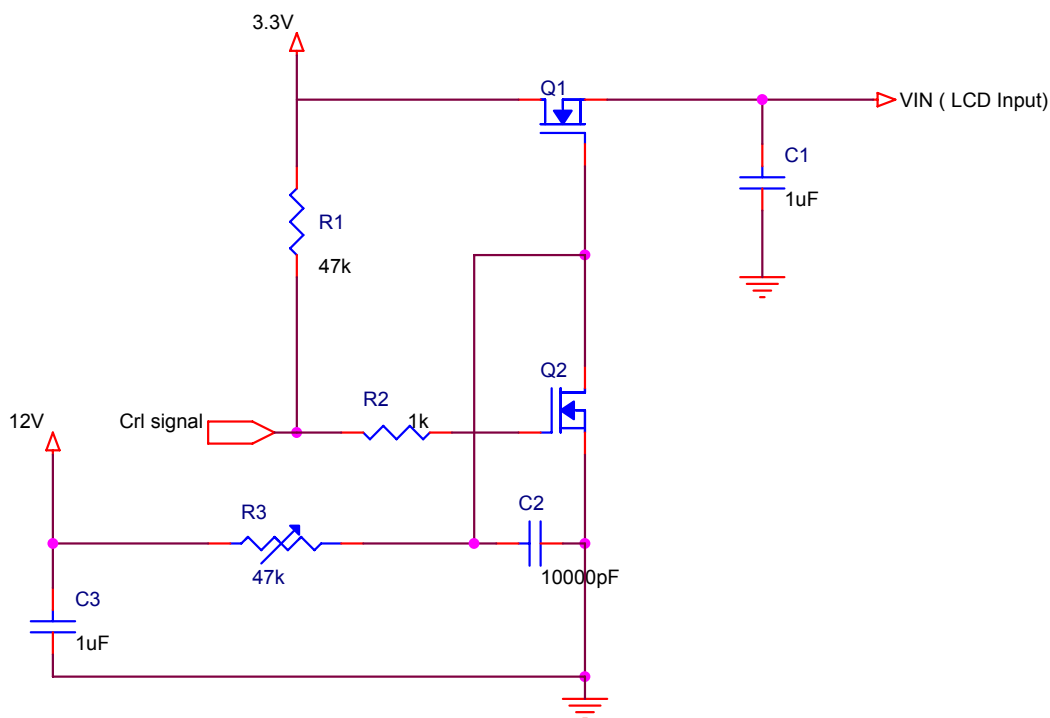

Control signal: High(+3.3V)→Low(GND)

Supply Voltage of rising time should be from R3 and C2 tune to 550 us.

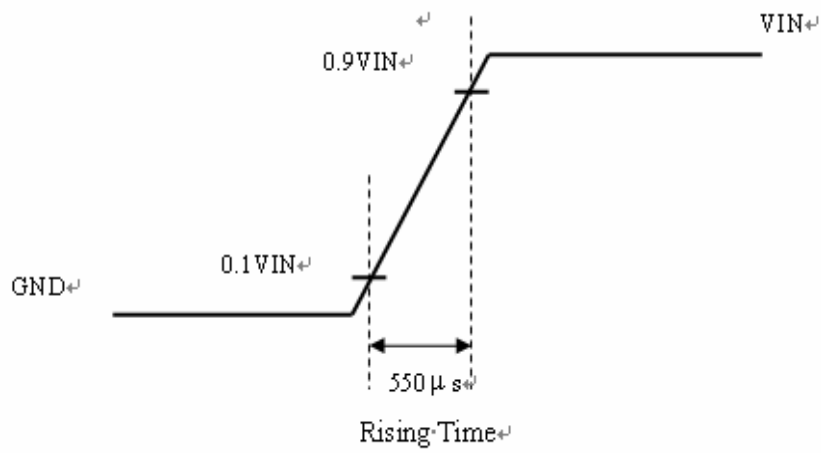

*4) Ifp Conditions : Pulse Width=0.1msec and Duty=1/10 °

3. ELECTRICAL CHARACTERISTICS

3.1TFT LCD

Ta=25°C

Item	Symbol	Min.	Typ	Max.	Unit	Note
Power Supply Voltage For LCD	VCC	3.0	3.3	3.6	V	*1)
Power Supply Voltage For LED	VDD	2.7	3.3	5	V	
Logic Input Voltage	VIH	VCC*0.7	--	VCC	V	
	VIL	0	--	VCC*0.3	V	

Remarks :

*1) VCC -dip codition:

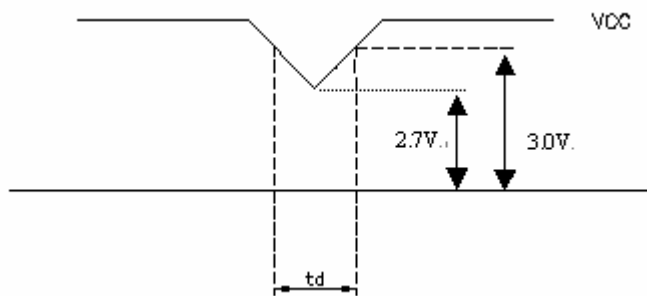
When $2.7\text{ V} \leq \text{VCC} < 3.0\text{ V}$, $t_d \leq 10\text{ ms}$. $\text{VCC} > 3.0\text{ V}$, VCC-dip condition should be same as VCC-turn-on condition.

3.2TFT-LCD current consumption

Item	Symbol	Min.	Typ	Max.	Unit	Note
LCD power current	ICC	--	TBD	TBD	mA	*1)
LED power current	IDD		TBD	TBD	mA	*2)

*1) Typical: Under 64 gray pattern
 Maximum: Under black pattern

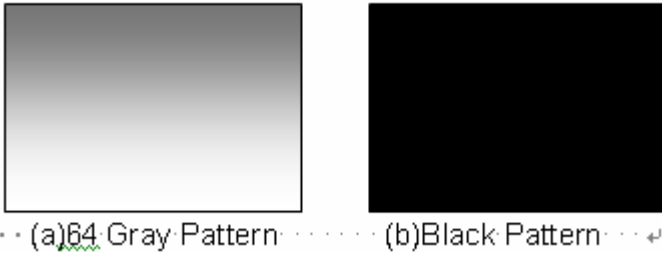

*2) Typical: When VDD is 3.3V
 Maximum: When VDD is 2.7V

3.3 Power 、 Signal sequence

- $t1 \leq 10ms$ $1 \text{ sec} \leq t5$
- $50ms \leq t2$ $200ms \leq t6$
- $0 < t3 \leq 50ms$ $200ms \leq t7$
- $0 < t4 \leq 10ms$

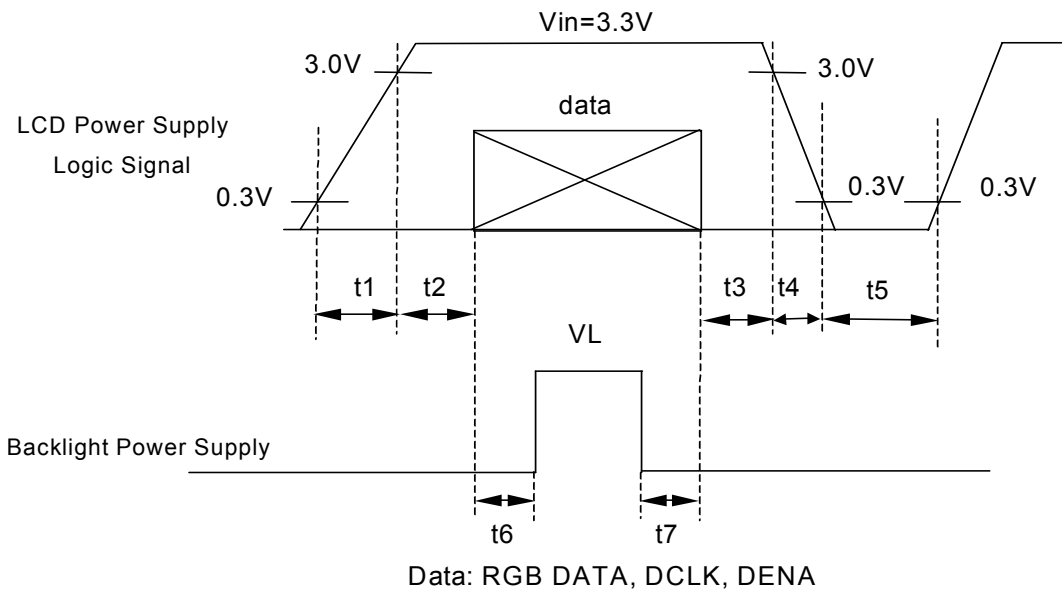

4. INTERFACE CONNECTION

(Connector type:40pin/0.5mm pitch/Bottom contact)-089N40-000R00-G2

Pin NO.	SYMBOL	DESCRIPTION
1	U/D	Up or Down Display Control
2	DMS	Selection DE or SYNC
3	Hsync	Horizontal SYNC.
4	Vcc	Power Supply for Digital Circuit
5	Vcc	Power Supply for Digital Circuit
6	Vcc	Power Supply for Digital Circuit
7	Vcc	Power Supply for Digital Circuit
8	Vsync	Vertical SYNC.
9	DE	Data Enable
10	V _{SS}	Power Ground
11	V _{SS}	Power Ground
12	ADJ	Adjust for LED brightness
13	B5	Blue Data 5 (MSB)
14	B4	Blue Data 4
15	B3	Blue Data 3
16	V _{SS}	Power Ground
17	B2	Blue Data 2
18	B1	Blue Data 1
19	B0	Blue Data 0 (LSB)
20	V _{SS}	Power Ground
21	G5	Green Data 5 (MSB)
22	G4	Green Data 4
23	G3	Green Data 3
24	V _{SS}	Power Ground
25	G2	Green Data 2
26	G1	Green Data 1
27	G0	Green Data 0 (LSB)
28	V _{SS}	Power Ground
29	R5	Red Data 5 (MSB)
30	R4	Red Data 4
31	R3	Red Data 3
32	V _{SS}	Power Ground
33	R2	Red Data 2
34	R1	Red Data 1
35	R0	Red Data 0 (LSB)
36	V _{SS}	Power Ground
37	V _{SS}	Power Ground
38	DCLK	Clock Signals
39	V _{SS}	Power Ground
40	L/R	Left or Right Display Control

Remarks :

1).ADJ adjust brightness to control Pin · Pulse duty the more small the more bright



2) ADJ signal = 0~3.3V , operation frequency: 20KHZ

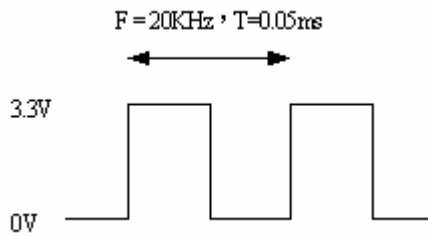

3) GND Pin must ground contact , can not be floating.

4) U/D and L/R are controlled function

L/R	U/D	Function
1	0	Normally display
0	0	Left and Right opposite
1	1	Up and Down opposite
0	1	Left and Right opposite , Up and Down opposite

5) DMS (Selection DE / SYNC mode)

DMS	Function
1	DE Mode
0	SYNC Mode

5. INPUT SIGNAL(DE ONLY MODE)

5.1 Timing Specification

ITEM		SYMBOL	MIN.	TYP.	MAX.	UNIT
DCLK	Period	t_{CLK}	16.67			ns
	Dot Clock	f_{CLK}	5	-	40	MHz
	Low Level Width	t_{WCL}	0.3	-	-	ns
	High Level Width	t_{WCH}	0.3	-	-	
DE	Setup Time	t_{DES}	5	-	-	ns
	Hold time	t_{DEH}	10	-	-	
	Horizontal Period	t_{HP}	750	800	900	t_{CLK}
	Horizontal Valid	t_{HV}	640			
	Horizontal Blank	t_{HBK}	110	160	260	
	Vertical Period	t_{VP}	515	525	560	t_{HP}
	Vertical Valid	t_{VV}	480			
	Vertical Blank	t_{VBK}	35	45	80	
	Vertical Frequency	f_V	55	60	65	
DATA	Setup Time	t_{DS}	4	-	-	ns
	Hold Time	t_{DH}	8	-	-	

Remarks :

*1) High level of logic signal is 80% ◦ Low level of logic signal is 20% ◦

*2) This module is operated by DE only mode

5.2 Timing sequence(Timing chart)

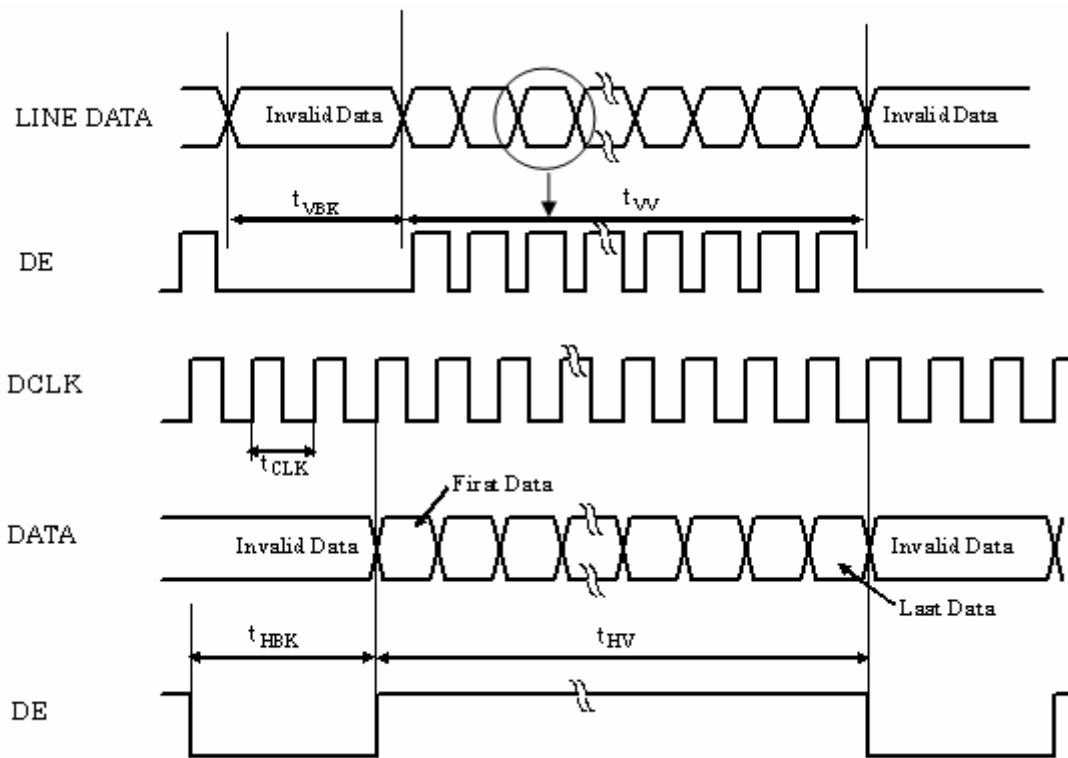
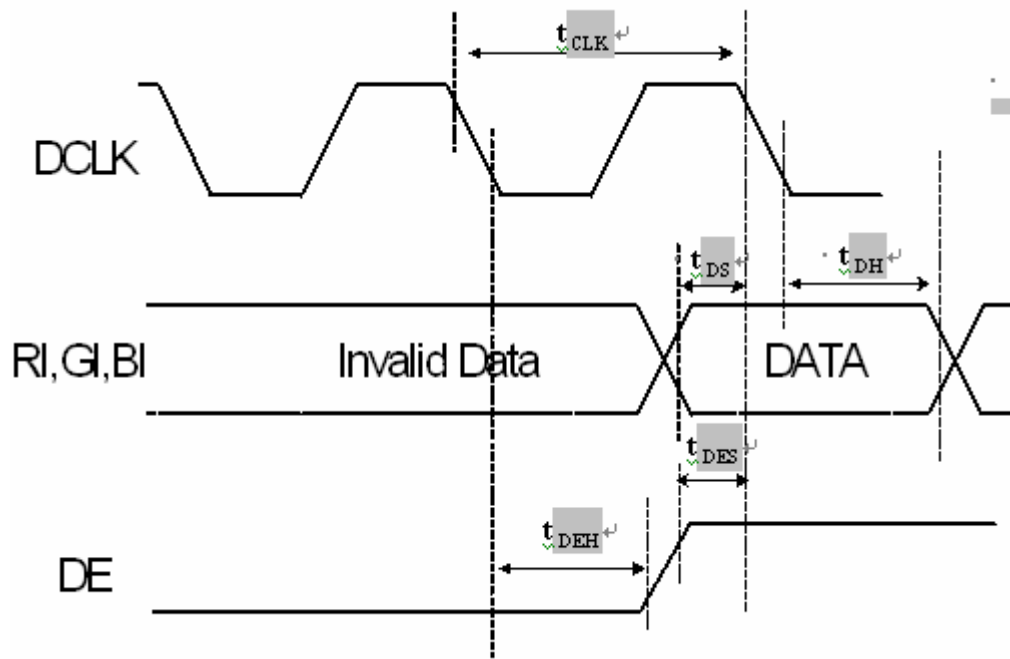

5.3 Color Data Assignment

COLOR	INPUT	R DATA						G DATA						B DATA					
		R5	R4	R3	R2	R1	R0	G5	G4	G3	G2	G1	G0	B5	B4	B3	B2	B1	B0
	DATA	MSB					LSB	MSB					LSB	MSB					LSB
	BLACK	0	0	0	0	0	0	0	0	0	0	0	0	0	0	0	0	0	0
	RED(63)	1	1	1	1	1	1	0	0	0	0	0	0	0	0	0	0	0	0
BASIC	GREEN(63)	0	0	0	0	0	0	1	1	1	1	1	1	0	0	0	0	0	0
COLOR	BLUE(63)	0	0	0	0	0	0	0	0	0	0	0	0	1	1	1	1	1	1
	CYAN	0	0	0	0	0	0	1	1	1	1	1	1	1	1	1	1	1	1
	MAGENTA	1	1	1	1	1	1	0	0	0	0	0	0	1	1	1	1	1	1
	YELLOW	1	1	1	1	1	1	1	1	1	1	1	1	0	0	0	0	0	0
	WHITE	1	1	1	1	1	1	1	1	1	1	1	1	1	1	1	1	1	1
	RED(0)	0	0	0	0	0	0	0	0	0	0	0	0	0	0	0	0	0	0
	RED(1)	0	0	0	0	0	1	0	0	0	0	0	0	0	0	0	0	0	0
	RED(2)	0	0	0	0	1	0	0	0	0	0	0	0	0	0	0	0	0	0
RED																			
	RED(62)	1	1	1	1	1	0	0	0	0	0	0	0	0	0	0	0	0	0
	RED(63)	1	1	1	1	1	1	0	0	0	0	0	0	0	0	0	0	0	0
	GREEN(0)	0	0	0	0	0	0	0	0	0	0	0	0	0	0	0	0	0	0
	GREEN(1)	0	0	0	0	0	0	0	0	0	0	1	0	0	0	0	0	0	0
	GREEN(2)	0	0	0	0	0	0	0	0	0	1	0	0	0	0	0	0	0	0
GREEN																			
	GREEN(62)	0	0	0	0	0	0	1	1	1	1	1	0	0	0	0	0	0	0
	GREEN(63)	0	0	0	0	0	0	1	1	1	1	1	1	0	0	0	0	0	0
	BLUE(0)	0	0	0	0	0	0	0	0	0	0	0	0	0	0	0	0	0	0
	BLUE(1)	0	0	0	0	0	0	0	0	0	0	0	0	0	0	0	0	0	1
	BLUE(2)	0	0	0	0	0	0	0	0	0	0	0	0	0	0	0	0	1	0
BLUE																			
	BLUE(62)	0	0	0	0	0	0	0	0	0	0	0	0	1	1	1	1	1	0
	BLUE(63)	0	0	0	0	0	0	0	0	0	0	0	0	1	1	1	1	1	1

Remarks :

(1) Definition of Gray Scale

color(n) : n is series of Gray Scale

The more n value is, the bright Gray Scale.

(2)Data:1-High,0-Low

6. BLOCK DIAGRAM

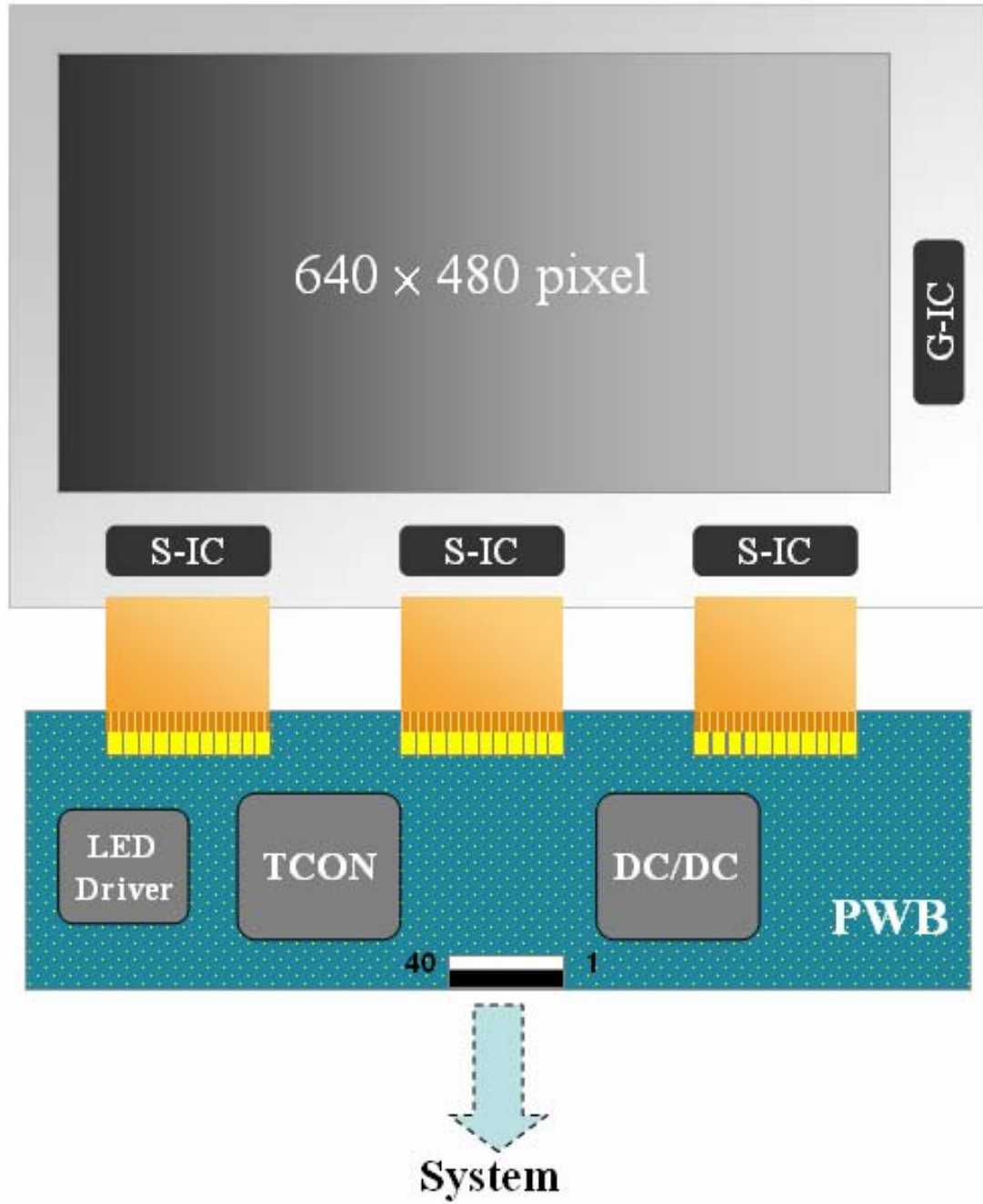

7. MECHANICAL DIMENSION

7.1 Front Side

[Unit : mm]

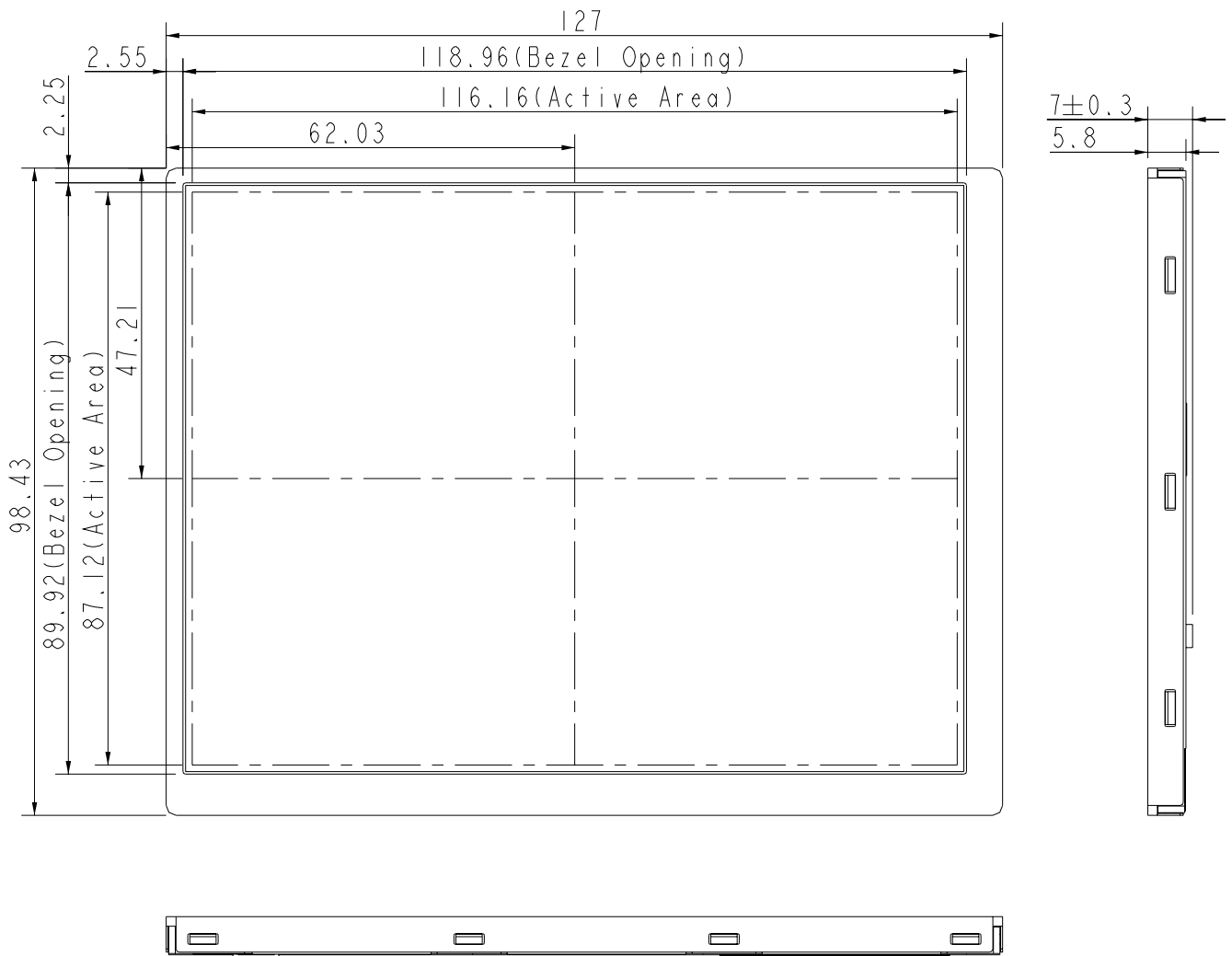

7.2 Rear Side

[Unit : mm]

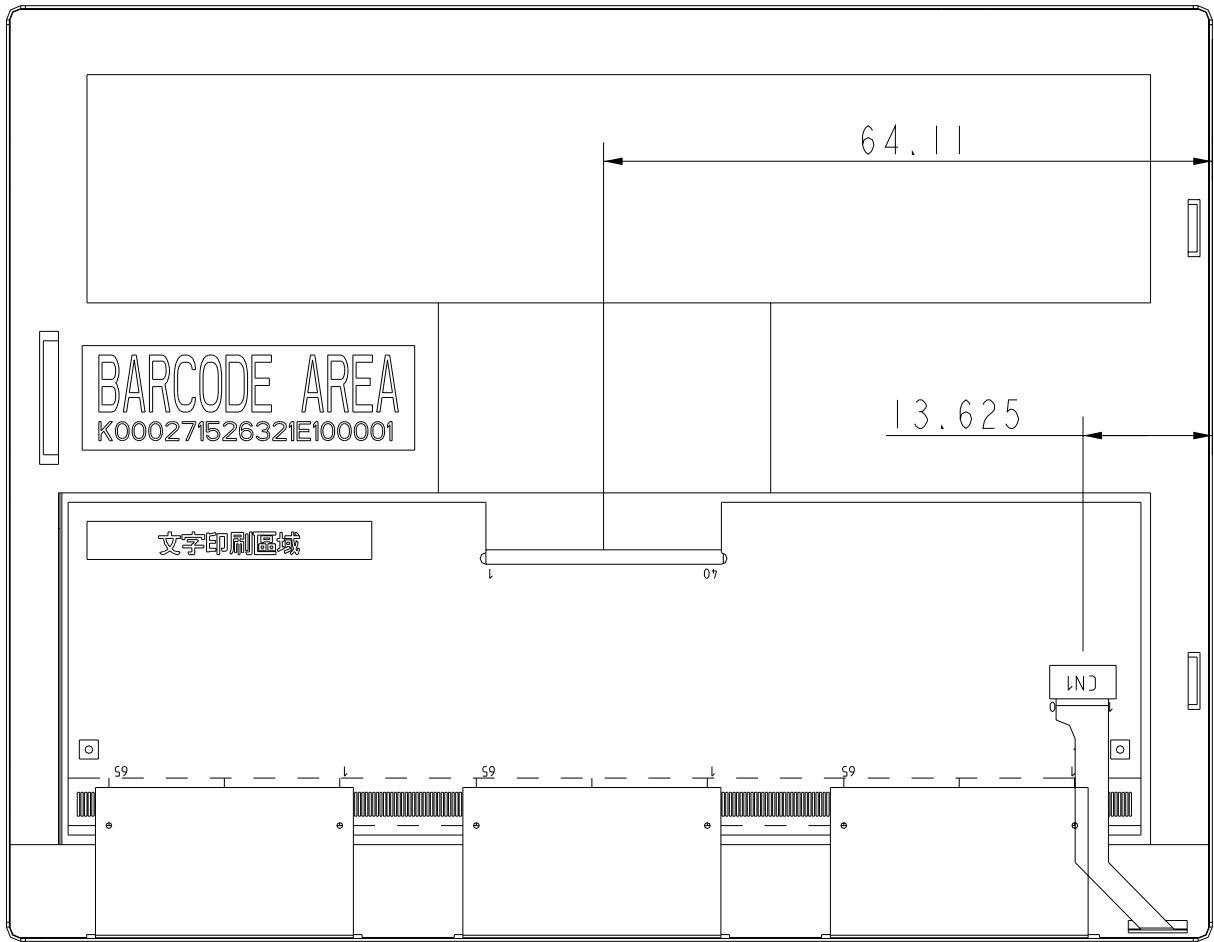

Remark : Un-indication tolerance is $\pm 0.3\text{mm}$

8. OPTICAL CHARACTERISTICS

ITEM	SYMBOL	CONDITION	MIN.	TYP.	MAX.	UNIT	Remarks	
Constrast Ratio	CR	Point-5	200	300	--	--	*1)*2)*3)	
Luminance	Lw	Point-5	180	220	--	cd/m ²	*1)*3)	
Luminance Uniformity	ΔL		70	80	--	%	*1)*3)	
Response Time (White - Black)	Tr+ Tf	Point-5	--	30	50	ms	*1)*3)*5)	
Viewing Angle	Horizontal	ϕ	CR \geq 10 Point-5	120	140	--	°	*1)*2)*4)
	Vertical			θ	80	100	--	°
Color Coordinate	White	Wx Wy	Point-5	0.273 0.289	0.313 0.329	0.353 0.369	--	*1)*3)
	Red	Rx Ry		TBD	TBD	TBD		
	Green	Gx Gy		TBD	TBD	TBD		
	Blue	Bx By		TBD	TBD	TBD		

Remarks :

*1)Measure condition : 25°C \pm 2°C , 60 \pm 10%RH , under10 Lux in the dark room.BM-5A (TOPCON) , viewing angle2° , VCC=3.3V , VDD=3.3V.

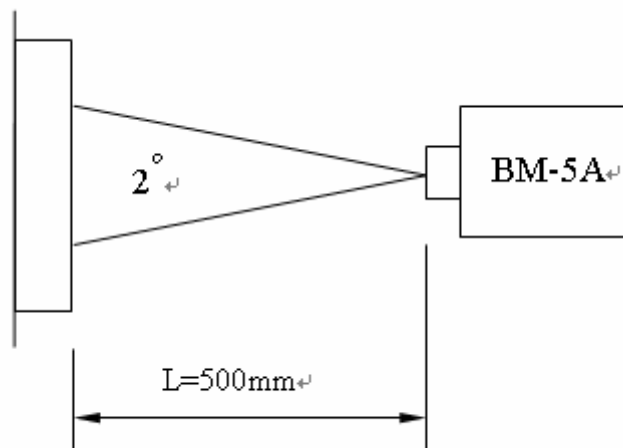

*2) Definition of contrast ratio :

Contrast Ratio (CR)= (White) Luminance of ON \div (Black) Luminance of OFF

*3) Definition of luminance :

Measure white luminance on the point 5 as figure8-1

Definition of Luminance Uniformity:

Measure white luminance on the point1、2、3、4、5 as figure8-1

$$\Delta L = [L(\text{MIN})/L(\text{MAX})] \times 100$$

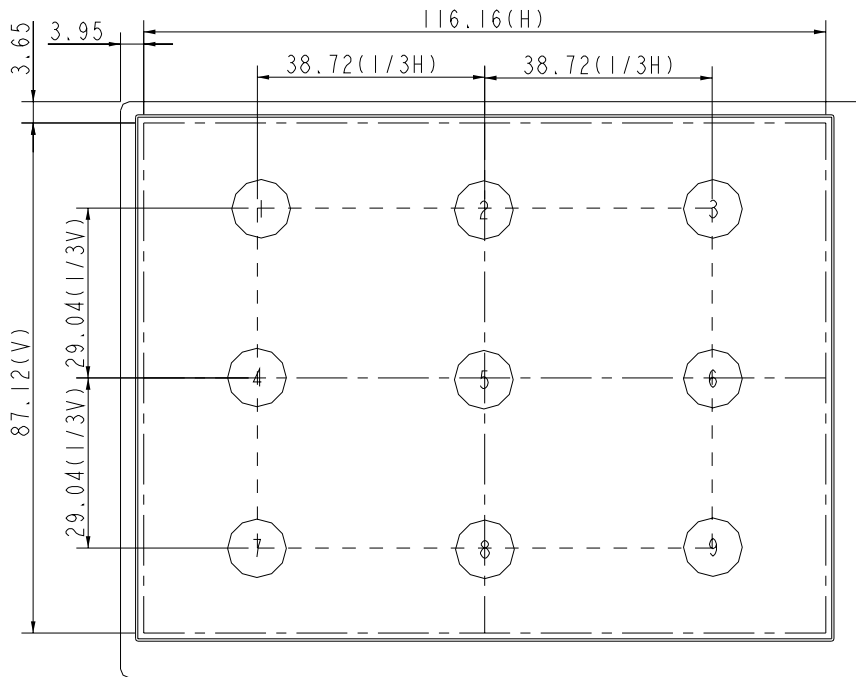

Fig8-1 Measuring point

*4) Definition of Viewing Angle(θ, ψ), refer to Fig8-2 as below :

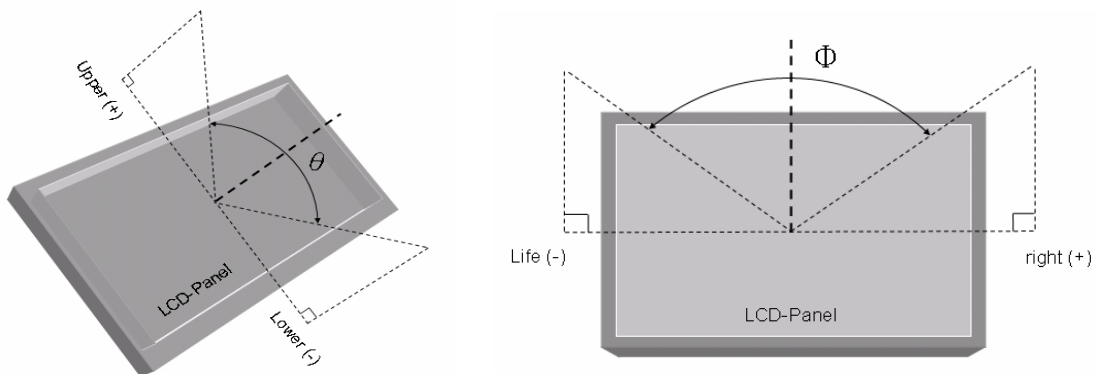

Fig8-2 Definition of Viewing Angle

*5) Definition of Response Time.(White-Black)

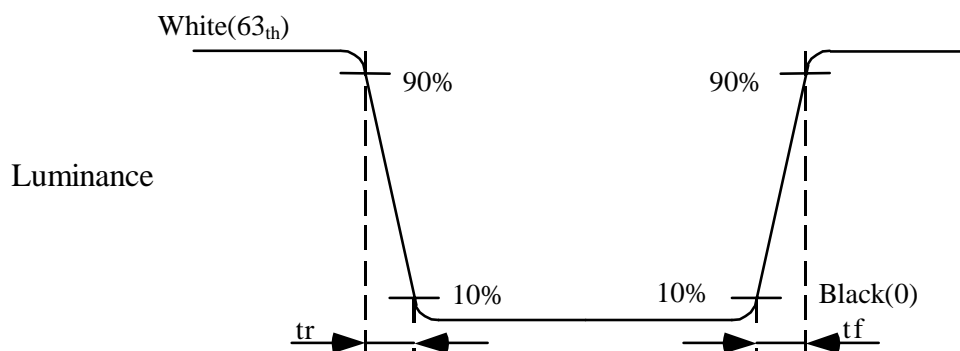

Fig8-3 Definition of Response Time(White-Black)

9. RELIABILITY TEST

9-1. Temperature and humidity

TEST ITEMS	CONDITIONS
High Temperature Operation	85°C , 240H
High Temperature Storage	90°C , 240H
High Temperature High Humidity Operation	60°C , 90%RH , 240H
Low Temperature Operation	-30°C , 240H
Low Temperature Storage	-40°C , 240H
Thermal Shock	-30°C (1Hr) ~ 85°C (1Hr) 200 cycles

9-2. Shock and Vibration

TEST ITEMS	CONDITIONS
Shock (Non-operation)	<ul style="list-style-type: none"> ● Shock level:980m/s²(equal to 100G) ● Waveform:half sinusoidal wave,6ms. ● Number of shocks:one shock input in each direction of three mutually perpendicular axes for a total of three shock inputs.
Vibration (Non-operation)	<ul style="list-style-type: none"> ● Frequency range:8~33.3Hz ● Stoke:1.3mm ● Vibration:sinusodial wave,perpendicularaxis(both x,y,z axis:2Hrs). ● Sweep:2.9G,33.3Hz-400Hz ● Cycle:15min

9-3. Judgment standard

The Judgment of the above test should be made as follow:

Pass:Normal display image with no obvious non-uniformity and no line defect.Partial trasformation of the module parts should be ignored.

Fail:No display image,obvious non-uniformity,or line defect.