

Specification for Approval

Product Name : Standard-369WV

Model Name : AMS369FG06-0

Description : 3.7" Visual WVGA 480x800 16M Color

Proposed by			Customer's Approval
Designed	Checked	Approved	
M. H. LEE Nov. 3 '2009			

*All information contained within this document is strictly private and belongs to the Samsung SMD Co., Ltd. It is to be treated as being marked "Proprietary and Confidential" and is intended only for the recipient(s) to whom it has been sent by us. It may also be legally privileged.
Also, contents in this document are subject to change after prior notice to the customer.*

Revision History

Date	Rev. No.	Contents	Remark
Apr. 27 '09	0.0	- Initial issue	-
Jun. 24 '09	1.0	Page 18 Changed 9.8 gamma values Page 31, 32 Updated 14.1 Product drawing and 14.2 FPCB drawing Added silk line on the stiffener Changed FPCB outline cutting tolerance in ZIF connector (13.1+/-0.15 => 13.0+/-0.05) and FPCB thickness tolerance (0.22+/-0.03 => 0.2+/-0.02)	-
Jul. 02 '09	2.0	Page 36 ~ 39 Updated 14.3 Packing specification	-
Aug. 20 '09	3.0	Page 31 Update Product drawing with conductive tape Page 32 Update FPCB drawing Page 39~ 44 Added Hazardous materials report	-
Sep. 15 '09	4.0	Page 7 Added " Full white(250nit) " in Test condition Page 45~46 Added Conductive tape Hazardous material report	-
Nov. 03 '09	5.0	Page 31 Updated Product drawing without conductive tape	-

SAMSUNG SMD CO., LTD.(All Rights Reserved).

Doc. No.: AMS369FG06-0	TITLE : 3.7" Visual WVGA 480*800 AMOLED	Rev. : 5.0	2/46
---	--	-------------------	-------------

Contents

1. Scope	5
2. Warranty	5
3. Features	6
4. Mechanical specification	6
5. Maximum rating	6
6. Electrical characteristics	7
7. Electro-optical characteristics	8
8. Input/Output terminal	10
8-1. I/O Connection	10
8-2. Circuit Block Diagram (Module)	11
8-3. Circuit Block Diagram (IC)	12
8-4. RGB Interface	13
9. Recommended Operating Sequence	14
9-1. Normal mode(Power ON sequence).....	14
9-2. RGB Interface	14
9-3. Panel Conditions Set(LTPS).....	15
9-4. Display Condition Set.....	15
9-5. Analog Power Condition Set.....	16
9-6. Power OFF sequence(display off sequence).....	16
9-7 Exit Standby mode	17
9-8 Gamma Value	18
10. AC Characteristics	19
10-1. Clock synchronous serial interface timing characteristics..	19
10-2. Reset Timing Characteristics.....	20
10-3. RGB Interface Timing Characteristics.....	21
11. Quality Level	22
11-1. Environment Condition	22
11-2. Sampling Procedure	23
11-3. Inspection Item	24

SAMSUNG SMD CO., LTD.(All Rights Reserved).

12. Reliability	26
12-1. Items of Reliability	26
13. Handling Precautions	28
13-1. Mounting Method	28
13-2. Caution of AMOLED Handling and Cleaning	28
13-3. Caution against Static Charge	28
13-4. Packing	28
13-5. Caution for Operation	29
13-6. Storage	29
13-7. Safety Precautions	29
13-8. Precautions before Use	30
14. Drawing	31
14-1. Product Drawing	31
14-2. FPCB Drawing	32
14-2-1. Schematic Diagram	33
14-2-2. Electronic Part List	34
14-3. Packing specification	35
14-3-1. Packing a cartoon box	35
14-3-2. Packing a pallet box	37
14-3-3. Packing tray drawing	38
15. Hazardous materials report	39

SAMSUNG SMD CO., LTD.(All Rights Reserved).

Doc. No.: AMS369FG06-0	TITLE : 3.7" Visual WVGA 480*800 AMOLED	Rev. : 5.0	4/46
----------------------------------	---	-------------------	------

1. Scope

This Specification defines general provisions as well as inspection standards for AMOLED module supplied by SAMSUNG SMD Co., LTD., If the event of unforeseen problems or unspecified items occurs, we naturally shall negotiate and agree to solution with customer.

2. Warranty

Basically, warranty term is **15 months** of reliability characteristics of quality level after the outgoing date in SAMSUNG SMD Co., LTD., and SAMSUNG SMD Co., LTD., could compensate for defectives which happens within warranty term under condition that the products should be stored or be used as specified under normal condition within the contents of specification. Otherwise, it is impossible to compensate for defectives when they happens by customer's mistake such as careless handling or circuit change, etc. And after 15 months of warranty term, all replacements for defectives will be charged.

This Specification stipulates the final and comprehensive requirements for the respective products hereof. Beyond this Specification, it is responsibility of the customer to explicitly disclose any additional requirements, information or reservations regarding these requirements to Samsung SMD prior to implementation, where any and all disclosures of the customer shall be with an authorized representative of Samsung SMD in writing. Samsung SMD shall not be responsible for safety, performance, functionality, compatibility of the system with which the Samsung SMD-supplied components are integrated unless such features have been expressly communicated and described in the Specification.

SAMSUNG SMD MAKES NO GUARANTY OR WARRANTY, EXPRESS OR IMPLIED INCLUDING BUT NOT LIMITED TO MERCHANTABILITY OR FITNESS FOR A PARTICULAR PURPOSE, TO ANY PARTY.

Moreover, any party should do their own due diligence regarding these requirements prior to implementation.

SAMSUNG SMD CO., LTD.(All Rights Reserved).

Doc. No.:
AMS369FG06-0

TITLE : 3.7" Visual WVGA 480*800
AMOLED

Rev. : 5.0

5/46

3. Features

- 1) Display Color : 16M_Color (RGB)
- 2) Display Format : 3.7" Visual WVGA 480 x 800 (240 RGBG x 800)
- 3) Interface : RGB-24bits, SPI-3 line
- 4) Driver IC : TL2796 By TOMATO LSI
- 5) Polarizer : Hard Coating Polarizer (2H)

4. Mechanical Specification

Item	Specifications	Unit
Outline dimension (Glass thickness)	53.94(W) x 90(H) x 1.5(T) (0.3t)	mm
Number of dots	240(W) x R(B)GB(R)G x 800(H)	Dots
Active area	48.24(W) x 80.4(H)	mm
Diagonal Inch	3.69	inch
Pixel pitch(RG or BG)	0.1005(W) x 0.1005(H)	mm

5. Maximum Rating

Item	Symbol	Min.	Max.	Unit	Note	
Supply voltage	Logic	VCI	-0.3	3.6	V	(1),(2)
		IOVCC	-0.3	3.6	V	(1),(2)
	Power	VBAT	0.3	6.0	V	(1),(2)
Input voltage	Vin	-0.5	IOVCC+0.5	V	(2)	
Operating temperature	Top	-20	70	°C	-	
Humidity	Hop	10	95	%(RH)	-	
Storage temperature	Tstg	-30	85	°C	-	
Humidity	Hstg	10	95	%(RH)		

Note 1) VCI, IOVCC, VBAT should satisfy the below condition of

$$VBAT > VCI, IOVCC > VSS (GND).$$

Note 2) If the supplied voltage exceeds the maximum limitation, LSI can be damaged permanently.

Therefore, while operating, it is recommend to use LSI within the maximum electrical limitation. If not, LSI can cause decreased reliability or operational problems.

Note 3) Wet Bulb Temperature should not exceed 29 at most and not have any dew condensation.

SAMSUNG SMD CO., LTD.(All Rights Reserved).

6. Electrical Characteristics

- Test Conditions : IOVCC=2.8V, VCI=2.8V, Vbat=3.8V, VSS=0V, Tamb=25 °C
at Full white(250nit) unless otherwise specified.

Item		Symbol	Condition	Min.	Typ.	Max.	Unit
Supply voltage	Logic	IOVCC	-	1.65	1.8	3.3	V
		VCI	-	2.5	2.9	3.3	
	Power	VBat	-	2.5	3.8	4.5	
Input Voltage	"H" level	VIH	-	0.8*IOVCC	-	IOVCC	V
	"L" level	VIL	-	-0.2	-	0.2*IOVCC	
Output Voltage	"H" level	VOH	IOH = -0.1mA IOL = 0.1mA	0.8*IOVCC	-	IOVCC	V
	"L" level	VOL		-0.2	-	0.2*IOVCC	
Leakage Current	Input	ILI	Vin=IOVCC or VSS	-1.0	-	1.0	uA
	Output	ILO		-3.0	-	3.0	uA
Supply Current	EL Power (250cd/m ² full white)	IBAT	VBAT=3.8V	-	320	380	mA
Driver IC Current Consumption		IOVCC	IOVCC =VCI=2.8V	-	-	1	mA
		IVCI		-	-	20	mA
		Istby (VBAT =3.8V)	IOVCC =VCI=2.8V	-	-	200	uA

SAMSUNG SMD CO., LTD.(All Rights Reserved).

7. Electro-optical characteristics

Item	Symbol	Temp	Condition	Min.	Typ.	Max.	Unit	Note	
Brightness		25 °C	Normal (White Mode)	200	250	300	cd/m ²	Center brightness	
Uniformity		25 °C	Normal (White Mode)	82	90	-	%	(1)	
Contrast ratio	K	25 °C	$\Phi=0^\circ, \theta=0^\circ$	2,000		-	-	(1),(2)	
Color of CIE coordinate	White	x	25 °C	$\Phi=0^\circ \theta=0^\circ$	0.280	0.300	0.320	-	(1),(2),(3)
		y			0.290	0.310	0.330	-	
	Red	x			0.625	0.675	0.725	-	
		y			0.275	0.325	0.375	-	
	Green	x			0.170	0.220	0.270	-	
		y			0.675	0.725	0.775	-	
	Blue	x			0.095	0.145	0.195	-	
		y			0.005	0.055	0.105	-	
Color Gamut		25 °C	vs. NTSC	-	105	-	%		
Life Time(5)		25 °C	50% Brightness drop @250cd/m ² , Full White	-	30,000	-	Hr	(4)	

Note1) Uniformity Measuring Point

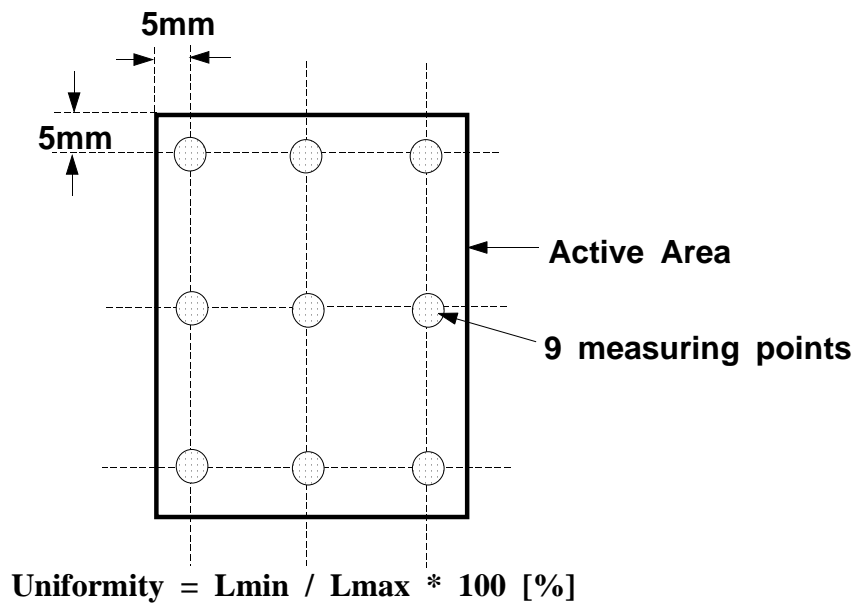

SAMSUNG SMD CO., LTD.(All Rights Reserved).

Note 2) Definition of contrast ratio (K)

$$\text{Contrast Ratio(K)} = \frac{\text{Brightness of selected dot (White patterned area) at } 250\text{cd/m}^2}{\text{Brightness of non-selected dot (Black patterned area) at } 250\text{cd/m}^2}$$

Note 3) Optical measuring system : temperature regulated chamber

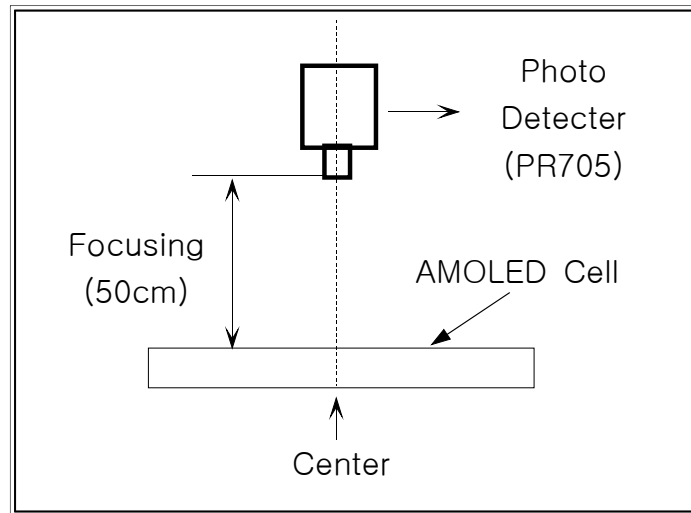

Note 4) Life Time

The elapsed time that the full white brightness decreases to the half of initial value.

SAMSUNG SMD CO., LTD.(All Rights Reserved).

8. Input/Output Terminal Assignment

8-1. I/O Connection

No.	I/O	Symbol	Function
1	Power	GND	Ground Terminal
2	Power	GND	Ground Terminal
3	Power	ELVSS	Power for LTPS
4	Power	ELVSS	Power for LTPS
5	-	NC	-
6	Power	ELVDD	Power for LTPS
7	Power	ELVDD	Power for LTPS
8	-	NC	-
9	Logic I/O Power	VDDI(IOVCC)	Data I/O power supply
10	Analog Power	VCI	Internal power for RAM
11	O	ELON	DC DC IC Enable
12	I	CSB	Chip select signal input (Low Active)
13	-	SCL	Serial data transfer clock input pin
14	I	SDI	Serial data input pin
15	I	SDO	Serial data output pin
16	I	ENABLE	Data enable signal pin for RGB I/F
17	I	VSYNC	Vertical sync signal of the RGB I/F
18	I	HSYNC	Horizontal sync signal of the RGB I/F
19	Power	GND	Ground Terminal
20	I	DOTCLK	Dot clock signal of the RGB I/F
21	Power	GND	Ground Terminal
22	I/O	D23	Unidirectional Data Bus
23	I/O	D22	Unidirectional Data Bus
24	I/O	D21	Unidirectional Data Bus
25	I/O	D20	Unidirectional Data Bus
26	I/O	D19	Unidirectional Data Bus
27	I/O	D18	Unidirectional Data Bus
28	I/O	D17	Unidirectional Data Bus
29	I/O	D16	Unidirectional Data Bus
30	I/O	D15	Unidirectional Data Bus
31	I/O	D14	Unidirectional Data Bus
32	I/O	D13	Unidirectional Data Bus
33	I/O	D12	Unidirectional Data Bus
34	I/O	D11	Unidirectional Data Bus
35	I/O	D10	Unidirectional Data Bus
36	I/O	D9	Unidirectional Data Bus
37	I/O	D8	Unidirectional Data Bus
38	I/O	D7	Unidirectional Data Bus
39	I/O	D6	Unidirectional Data Bus
40	I/O	D5	Unidirectional Data Bus
41	I/O	D4	Unidirectional Data Bus
42	I/O	D3	Unidirectional Data Bus
43	I/O	D2	Unidirectional Data Bus
44	I/O	D1	Unidirectional Data Bus
45	I/O	D0	Unidirectional Data Bus
46	I/O	GND	Ground Terminal
47	I	RESETB	Reset Signal (0: reset, 1: normal operation)
48	-	MTP_VPP2	Connection to VCI when it is not EEPROM write program mode.
49	-	MTP_VPP1	Connection to GND when it is not EEPROM write program mode.
50	-	GND	Ground Terminal
51	-	GND	Ground Terminal

SAMSUNG SMD CO., LTD.(All Rights Reserved).

8-2. Circuit block diagram (Module)

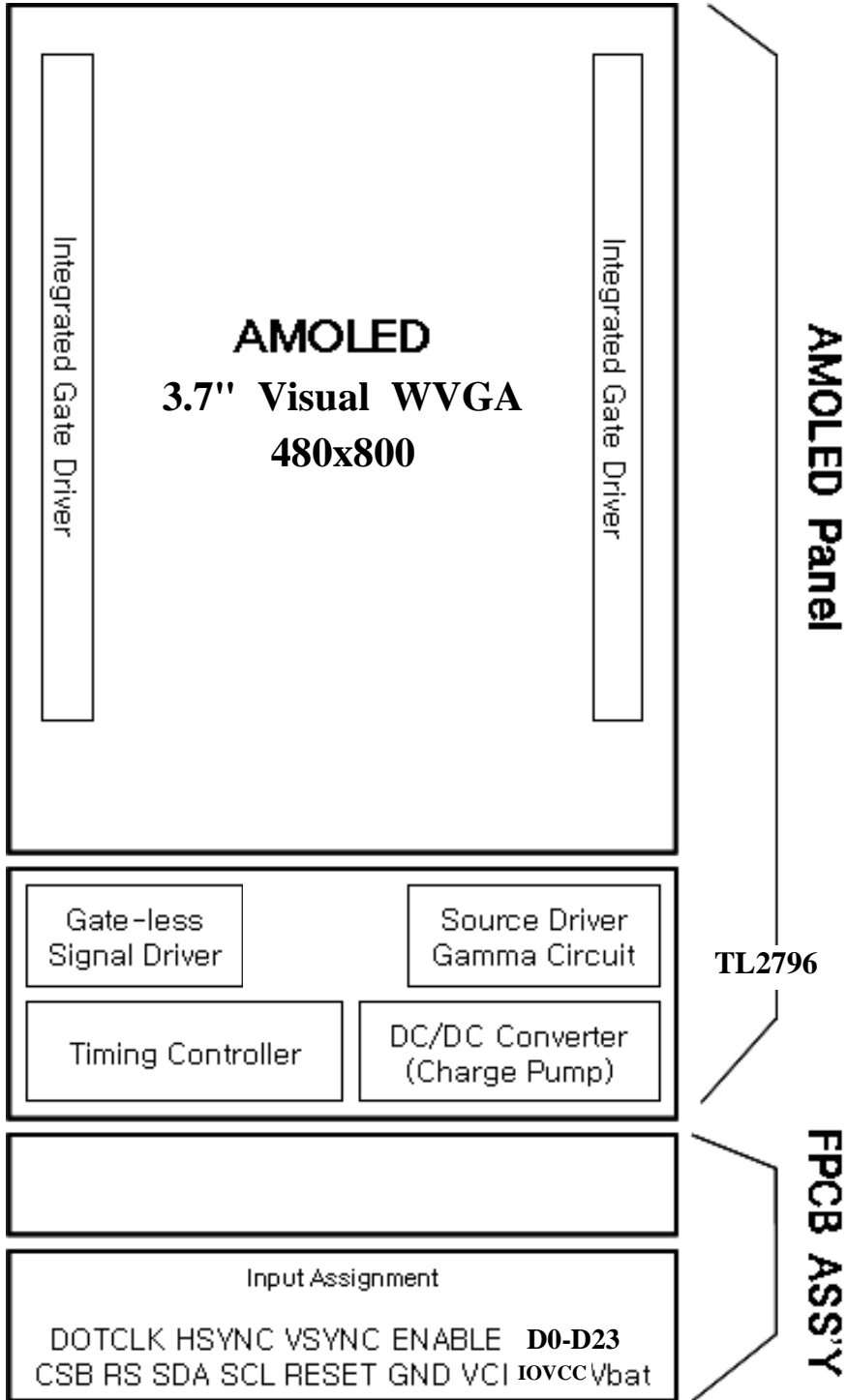

SAMSUNG SMD CO., LTD.(All Rights Reserved).

<p>Doc. No.: AMS369FG06-0</p>	<p>TITLE : 3.7" Visual WVGA 480*800 AMOLED</p>	<p>Rev. : 5.0</p>	<p>11/46</p>
--	---	--------------------------	--------------

8-3. Circuit block diagram (IC)

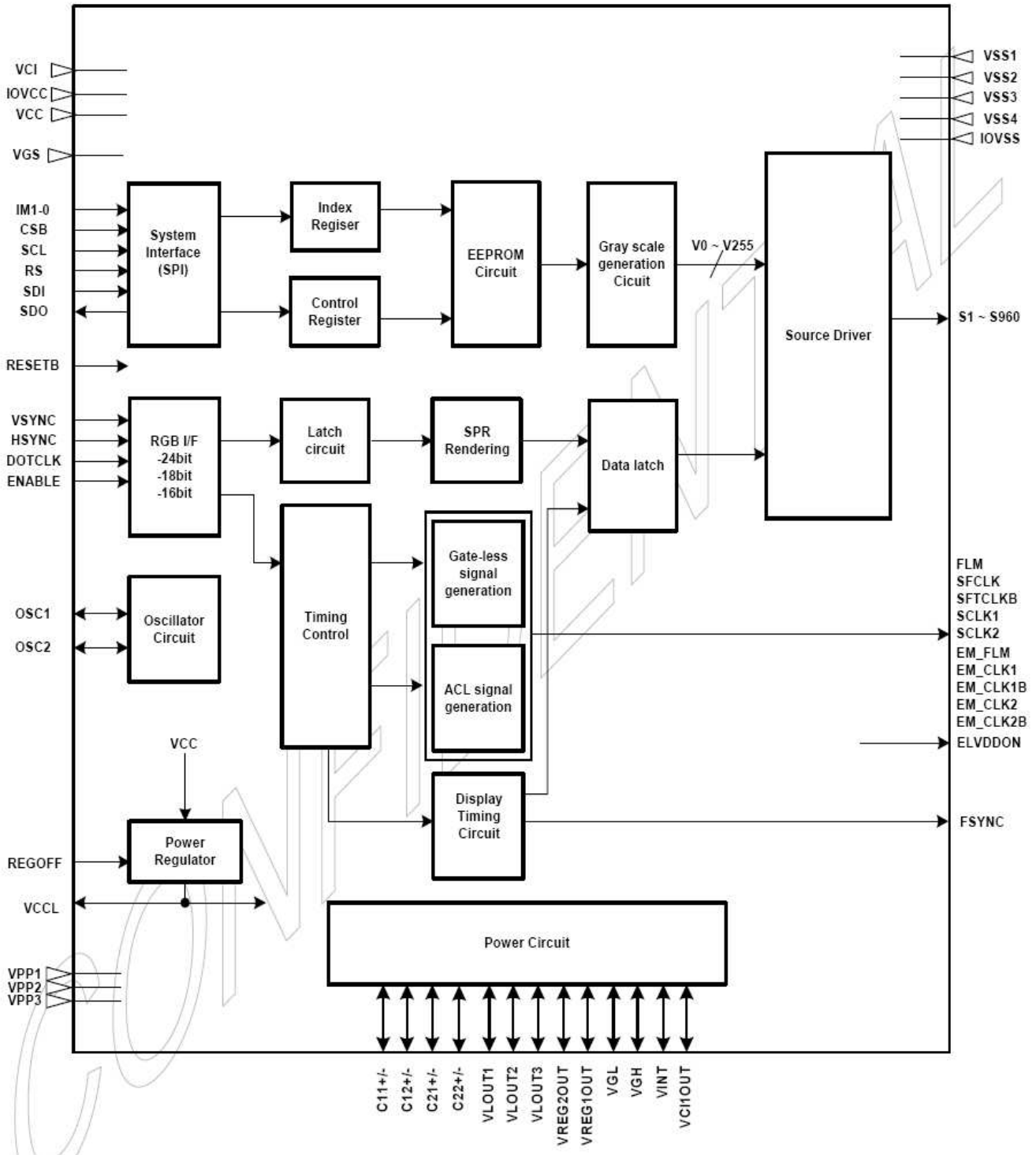

SAMSUNG SMD CO., LTD.(All Rights Reserved).

8-4. RGB Interface

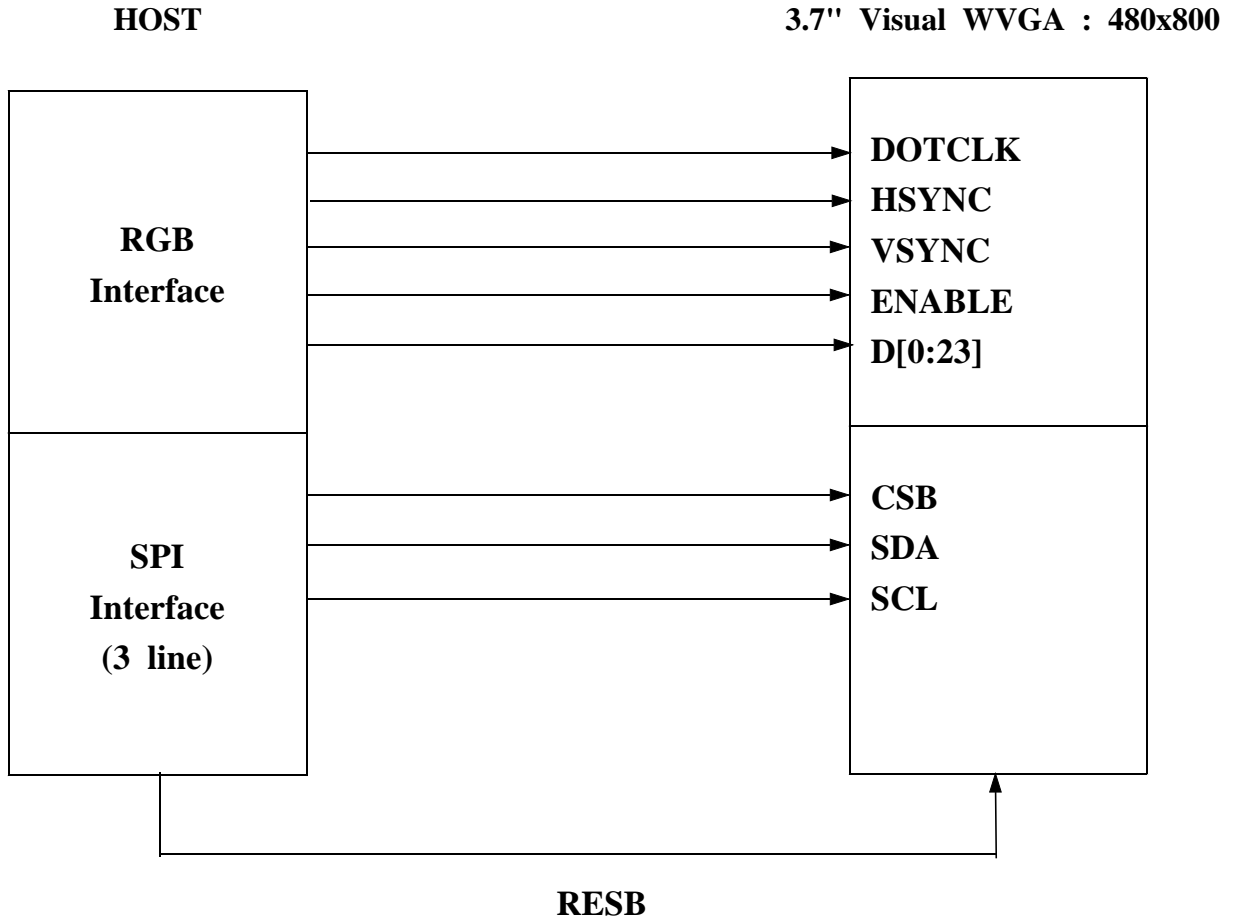

SAMSUNG SMD CO., LTD.(All Rights Reserved).

9. Recommended Operating Sequence

9-1 Normal mode(Power ON sequence)

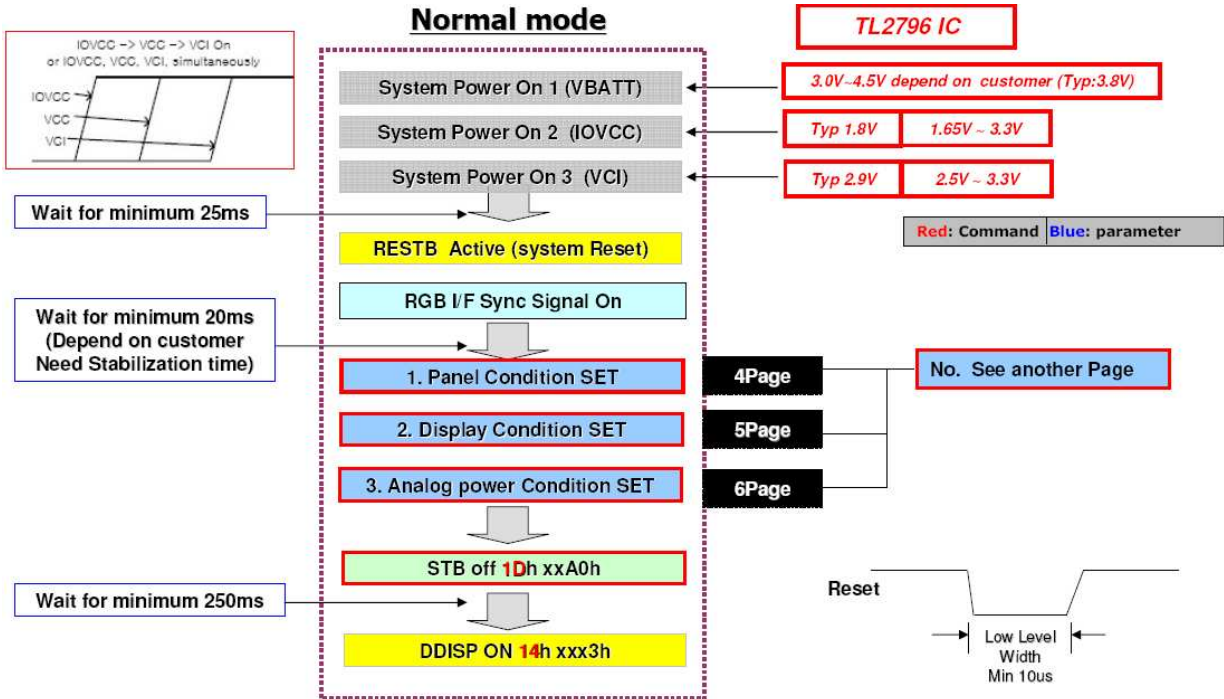

9-2 RGB Interface

Instruction format

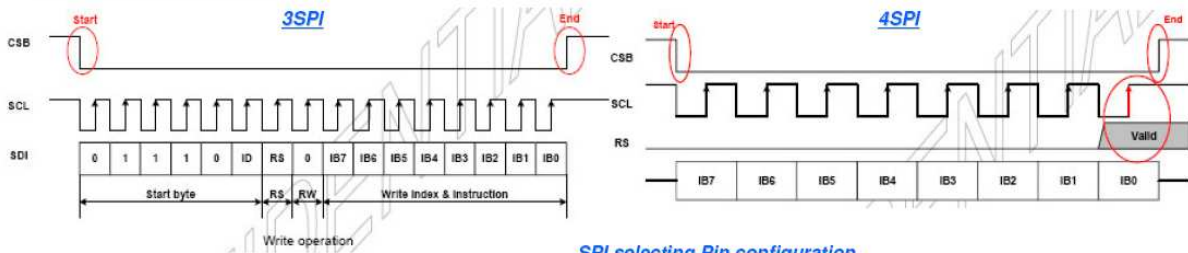

SPI selecting Pin configuration

IM1	IM0/ID	SPI mode
GND	I/D	3-Pin Serial Peripheral Interface
IOVCC	GND	4-Pin Serial Peripheral Interface

image data format

- 16M colors

CM = "00"

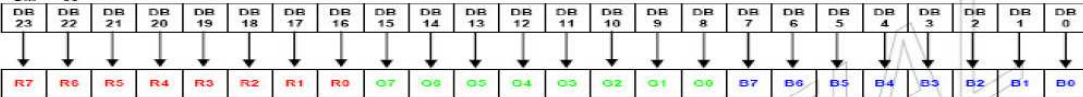

- 262K colors

CM = "01"

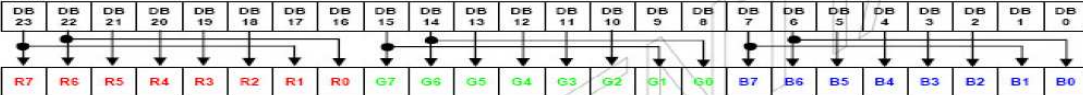

SAMSUNG SMD CO., LTD.(All Rights Reserved).

9-3 Panel Condition Set(LTPS)

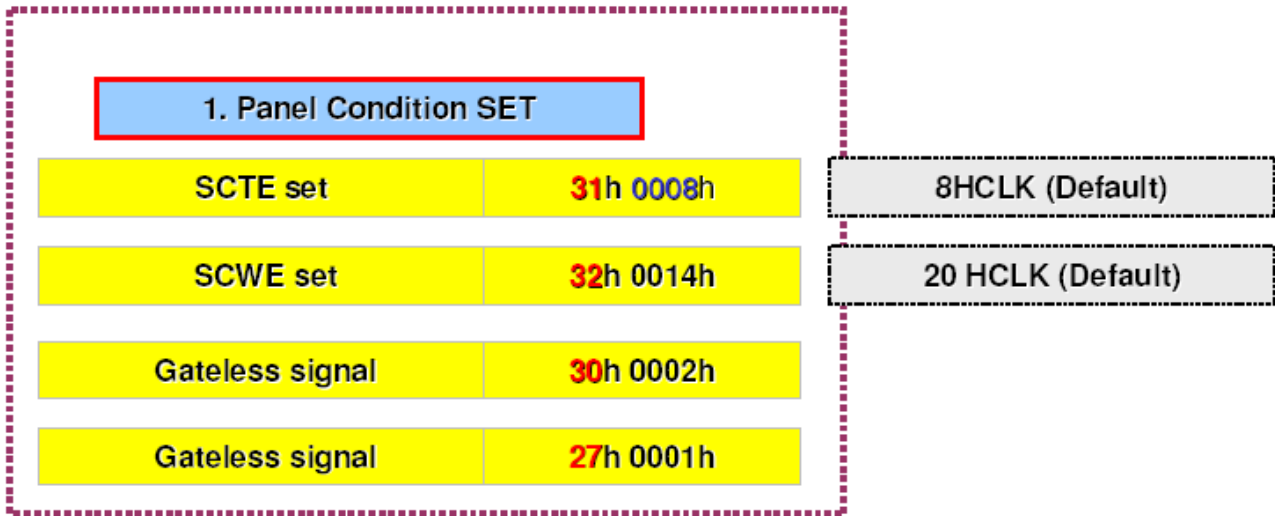

9-4 Display Condition Set

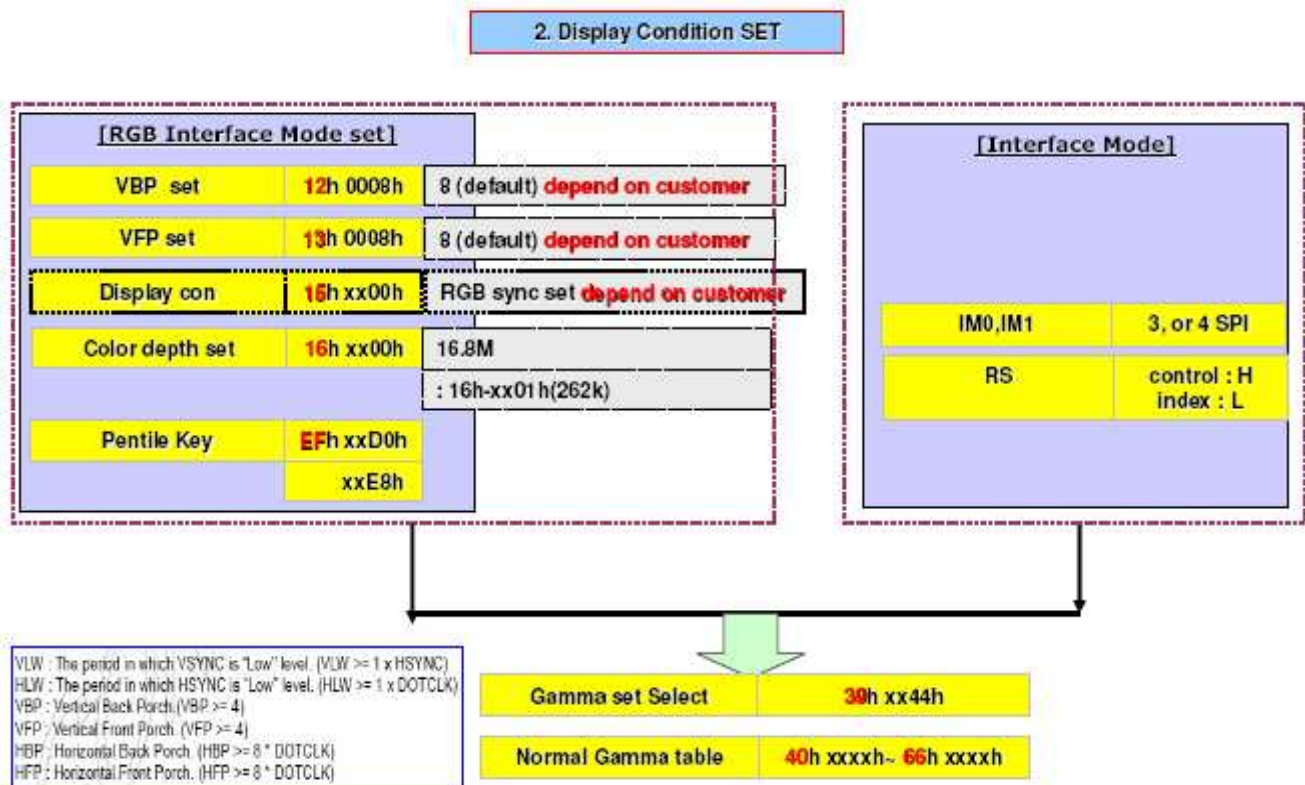

SAMSUNG SMD CO., LTD.(All Rights Reserved).

9-5 Analog Power Condition Set

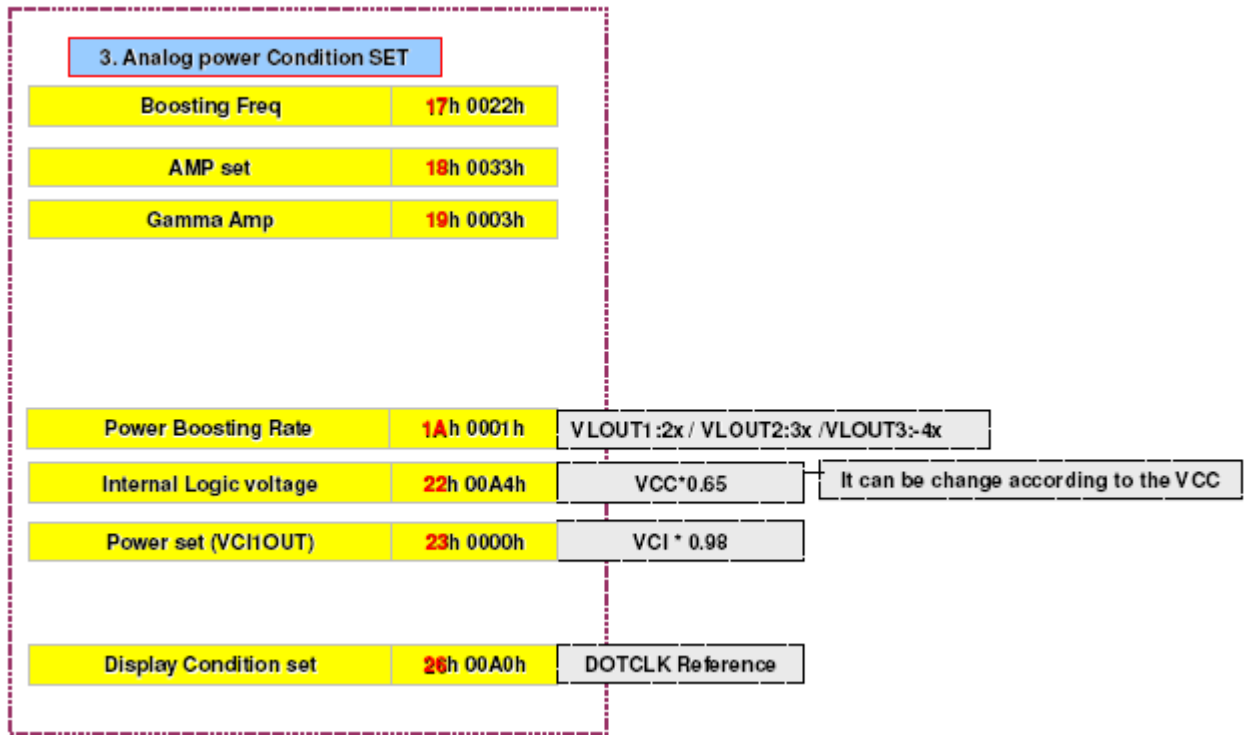

9-6 Power OFF sequence(display off sequence)

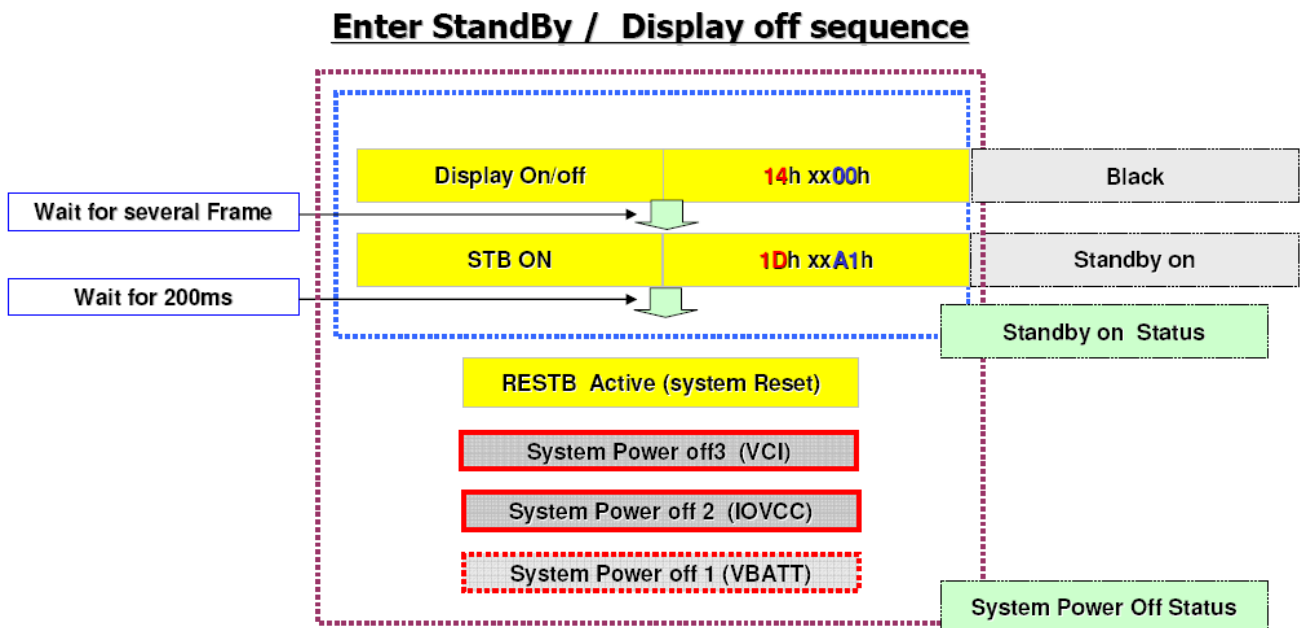

SAMSUNG SMD CO., LTD.(All Rights Reserved).

9-7 Exit Standby mode

Exit Standby mode

- If you've done Standby mode by "STB",
You can skip "RESET active"

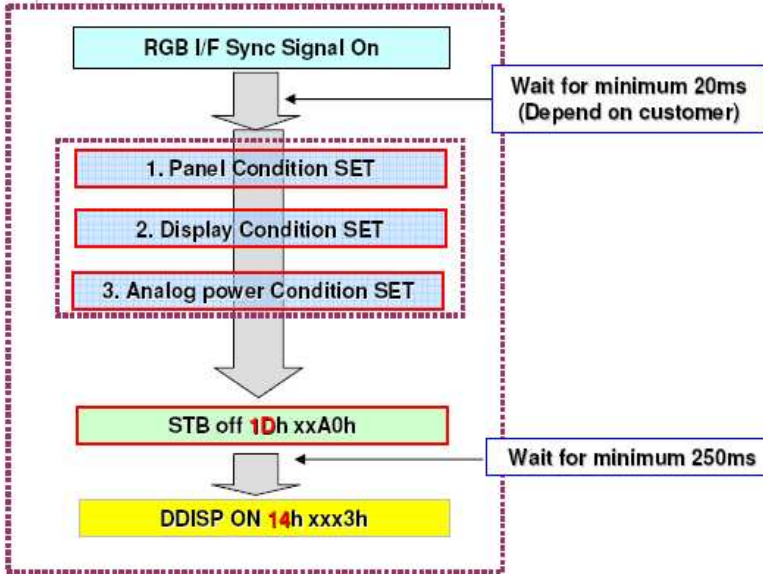

Refresh mode

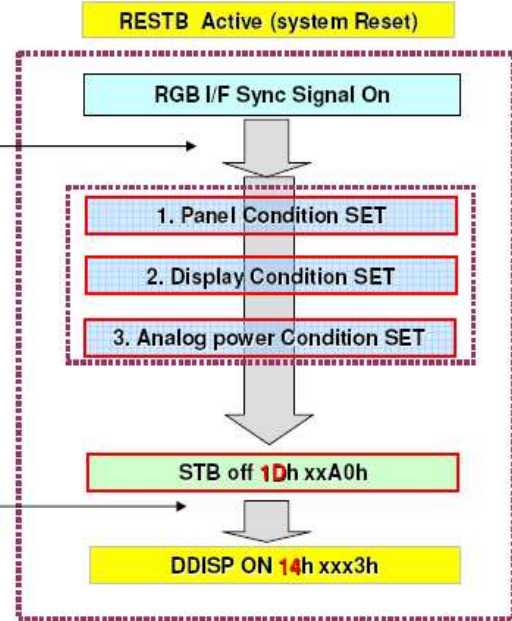

※ caution : Whenever RESET is done,
All registers are set clear with Default value

SAMSUNG SMD CO., LTD.(All Rights Reserved).

9-8 Gamma Values

L	250		Gamma	2.2	Reg. Setting		Reg. Setting		Reg. Setting	
		R	G	B	Reg. Setting		Reg. Setting		Reg. Setting	
V255	250.00	44	43	5C	46h	0044h	56h	0043h	66h	005Ch
V127	53.96	1F	1F	1B	45h	001Fh	55h	001Fh	65h	001Bh
V63	11.56	27	26	24	44h	0027h	54h	0026h	64h	0024h
V31	2.44	27	24	25	43h	0027h	53h	0024h	63h	0025h
V15	0.51	2A	17	2A	42h	002Ah	52h	0017h	62h	002Ah
V5	0.06	3F	00	3F	41h	003Fh	51h	0000h	61h	003Fh
V0	0.02	00	00	00	40h	0000h	50h	0000h	60h	0000h

L	200		Gamma	2.2	Reg. Setting		Reg. Setting		Reg. Setting	
		R	G	B	Reg. Setting		Reg. Setting		Reg. Setting	
V255	200.00	3E	3D	53	46h	003Eh	56h	003Dh	66h	0053h
V127	43.17	21	20	1D	45h	0021h	55h	0020h	65h	001Dh
V63	9.25	27	27	25	44h	0027h	54h	0027h	64h	0025h
V31	1.96	29	25	27	43h	0029h	53h	0025h	63h	0027h
V15	0.41	28	10	28	42h	0028h	52h	0010h	62h	0028h
V5	0.06	3F	00	3F	41h	003Fh	51h	0000h	61h	003Fh
V0	0.02	00	00	00	40h	0000h	50h	0000h	60h	0000h

L	150		Gamma	2.2	Reg. Setting		Reg. Setting		Reg. Setting	
		R	G	B	Reg. Setting		Reg. Setting		Reg. Setting	
V255	150.00	37	36	4A	46h	0037h	56h	0036h	66h	004Ah
V127	32.38	23	22	1F	45h	0023h	55h	0022h	65h	001Fh
V63	6.94	28	28	26	44h	0028h	54h	0028h	64h	0026h
V31	1.47	29	25	28	43h	0029h	53h	0025h	63h	0028h
V15	0.31	2D	0B	2B	42h	002Dh	52h	000Bh	62h	002Bh
V5	0.05	3F	00	3F	41h	003Fh	51h	0000h	61h	003Fh
V0	0.02	00	00	00	40h	0000h	50h	0000h	60h	0000h

L	100		Gamma	2.2	Reg. Setting		Reg. Setting		Reg. Setting	
		R	G	B	Reg. Setting		Reg. Setting		Reg. Setting	
V255	100.00	2F	2E	3F	46h	002Fh	56h	002Eh	66h	003Fh
V127	21.59	24	24	21	45h	0024h	55h	0024h	65h	0021h
V63	4.63	2B	29	29	44h	002Bh	54h	0029h	64h	0029h
V31	0.99	2A	25	29	43h	002Ah	53h	0025h	63h	0029h
V15	0.22	30	00	2F	42h	0030h	52h	0000h	62h	002Fh
V5	0.04	3F	00	3F	41h	003Fh	51h	0000h	61h	003Fh
V0	0.02	00	00	00	40h	0000h	50h	0000h	60h	0000h

L	50		Gamma	2.2	Reg. Setting		Reg. Setting		Reg. Setting	
		R	G	B	Reg. Setting		Reg. Setting		Reg. Setting	
V255	50.00	24	23	31	46h	0024h	56h	0023h	66h	0031h
V127	10.80	27	27	24	45h	0027h	55h	0027h	65h	0024h
V63	2.33	2D	2A	2B	44h	002Dh	54h	002Ah	64h	002Bh
V31	0.50	2C	22	2C	43h	002Ch	53h	0022h	63h	002Ch
V15	0.12	3C	00	3B	42h	003Ch	52h	0000h	62h	003Bh
V5	0.03	3F	00	3F	41h	003Fh	51h	0000h	61h	003Fh
V0	0.02	00	00	00	40h	0000h	50h	0000h	60h	0000h

SAMSUNG SMD CO., LTD.(All Rights Reserved).

10. AC Characteristics

10-1 Clock synchronous serial interface timing characteristics

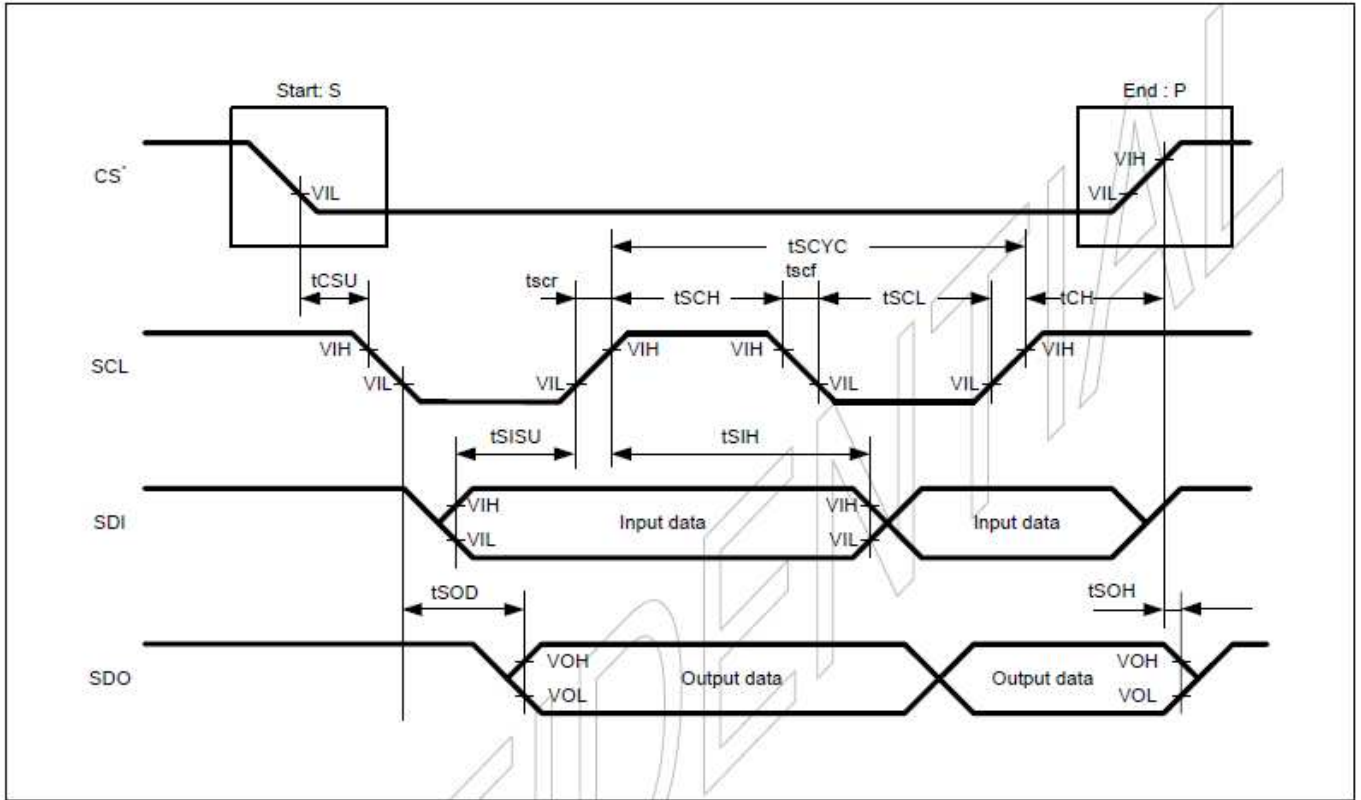

IOVCC=1.65 to 3.3V, VCC= 2.4 to 3.3V operation

Item	Symbol	Min.	Typ.	Max.	Unit
Write (received)	tSCYC	100	-	-	ns
Read (transmitted)	tSCYC	350	-	-	ns
Write (received)	tSCH	40	-	-	ns
Read (transmitted)	tSCH	150	-	-	ns
Write (received)	tSCL	40	-	-	ns
Read (transmitted)	tSCL	150	-	-	ns
Serial clock rise/fall time	tScR, tScF	-	-	20	ns
Chip select set up time	tCSU	20	-	-	ns
Chip select hold time	tCH	60	-	-	ns
Serial input data set up time	tSISU	30	-	-	ns
Serial input data hold time	tSIH	30	-	-	ns
Serial output data delay time	tSOD	-	-	130	ns
Serial output data hold time	tSOH	5	-	-	ns

SAMSUNG SMD CO., LTD.(All Rights Reserved).

10-2 Reset Timing Characteristics

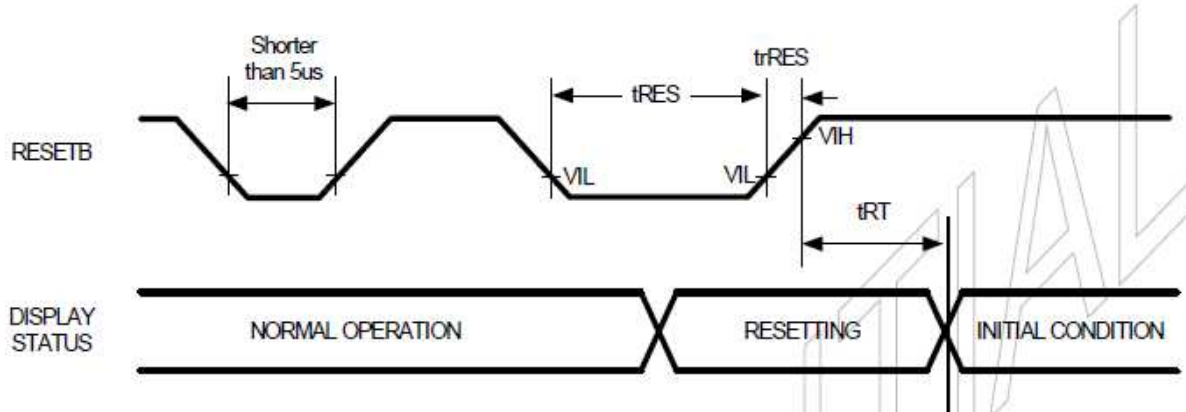

IOVCC=1.65 to 3.3V, VCC= 2.4 to 3.3V operation

Item	Symbol	Unit	Min.	Typ.	Max.
Reset low-level width	t_{RES}	μs	10	-	-
Reset rise time	t_{rRES}	μs	-	-	2
Reset cancel	t_{RT}	ms			1

Reset description

RESETB Pulse	Action
Shorter than 5us	Reset rejected
Longer than 10us	Reset
Between 5 ~ 10us	Reset starts

SAMSUNG SMD CO., LTD.(All Rights Reserved).

10-3 RGB Interface Timing Characteristics

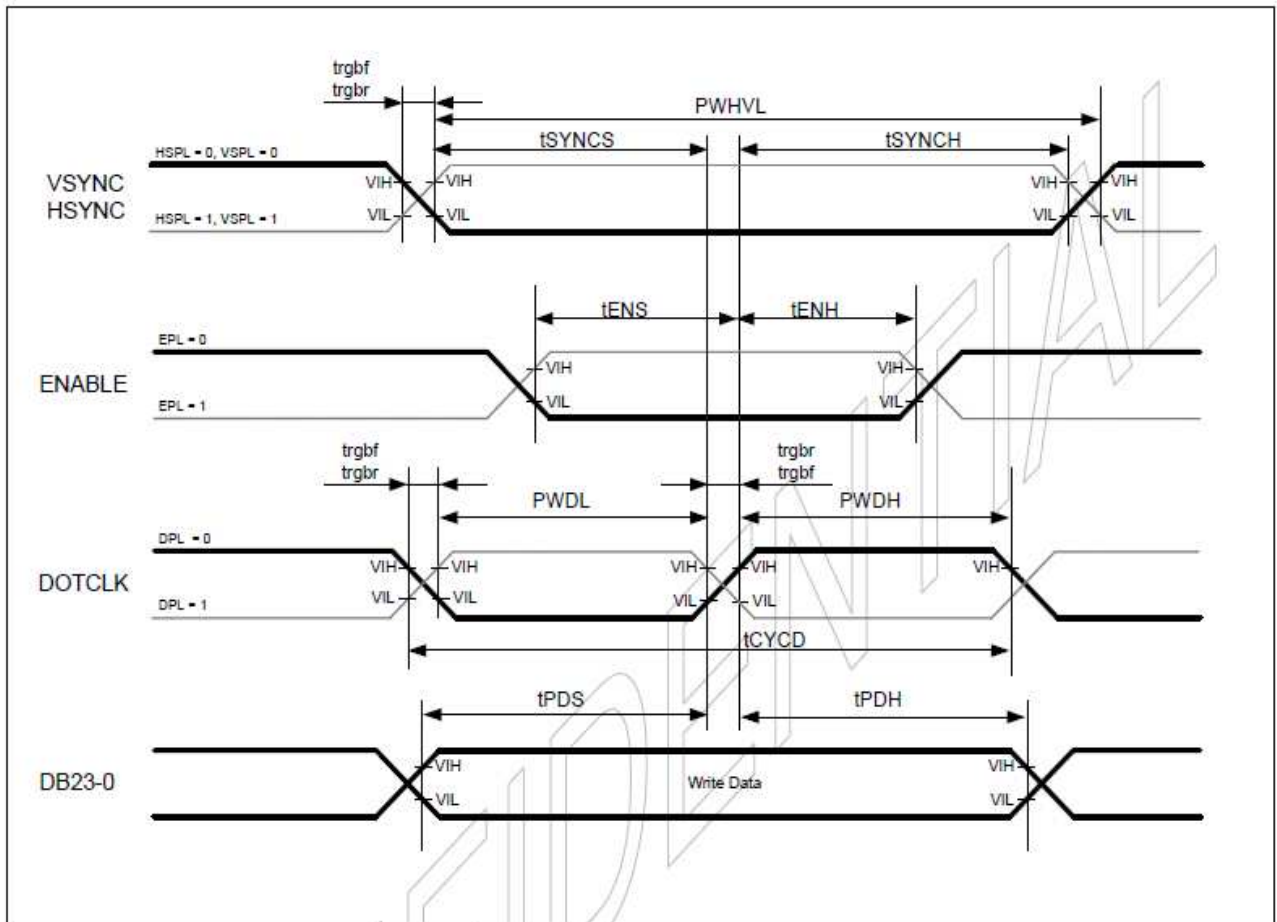

RGB interface(16/18/24-bit), IOVCC=1.65 to 3.3V, VCC= 2.4 to 3.3V operation

Item	Symbol	Min.	Typ.	Max.	Unit
VSYNC / HSYNC "Low" level pulse width	PWHVL	1	-	-	DOTCLK
VSYNC / HSYNC set up time	tSYNCS	10	-	-	ns
VSYNC / HSYNC hold time	tSYNCH	10	-	-	ns
ENABLE set up time	tENS	10	-	-	ns
ENABLE hold time	tENH	10	-	-	ns
DOTCLK "Low" level pulse width	PWDL	10	-	-	ns
DOTCLK "High" level pulse width	PWDH	10	-	-	ns
DOTCLK cycle time	tCYCD	30	-	-	ns
Data set up time	tPDS	7	-	-	ns
Data hold time	tPDH	7	-	-	ns
DOTCLK, VSYNC, HSYNC rising, falling time	trgbr, trgbf	-	-	15	ns

Note 1) Above AC characteristics condition is in case of VCCL >= 1.8V irrespective of VCC.

SAMSUNG SMD CO., LTD.(All Rights Reserved).

11. Quality Level

11-1. Environment Condition

The environmental conditions for inspection shall be as follows.

① Temperature & Humidity

Room temperature : $22 \pm 3^{\circ}\text{C}$

Humidity : $65 \pm 20\%RH$

② Viewing distance : 30cm

Viewing angle(tolerance) : $\pm 30^{\circ}$

③ Visual Inspection Condition : 200cd/m^2 , 150 ± 50 lux

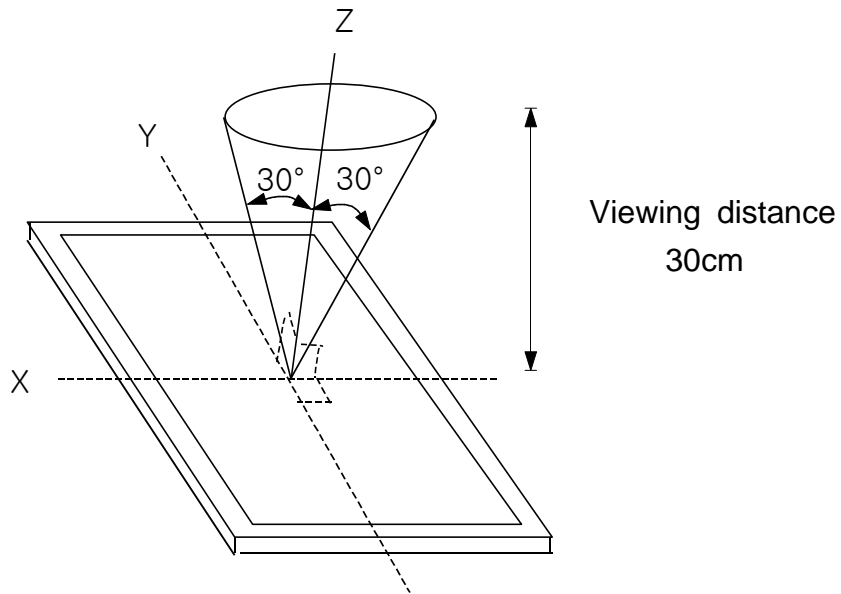

SAMSUNG SMD CO., LTD.(All Rights Reserved).

11-2. Sampling Procedures for each item's acceptance table

Defect type	Sampling Procedures	AQL
Major Defect	MIL-STD-105D Inspection level I normal inspection single sample inspection	0.65
Minor Defect	MIL-STD-105D Inspection level I normal inspection single sample inspection	0.65

① Major defect

A major defect refers to a defect which may substantially degrade usability for product applications.

② Minor defect

A minor defects refers to a defect which is not considered to substantially degrade product application, or a defect which deviates from existing standards almost unrelated to the effective use of the product or its operation.

③ Defect application zone : Active Area + Viewing Area

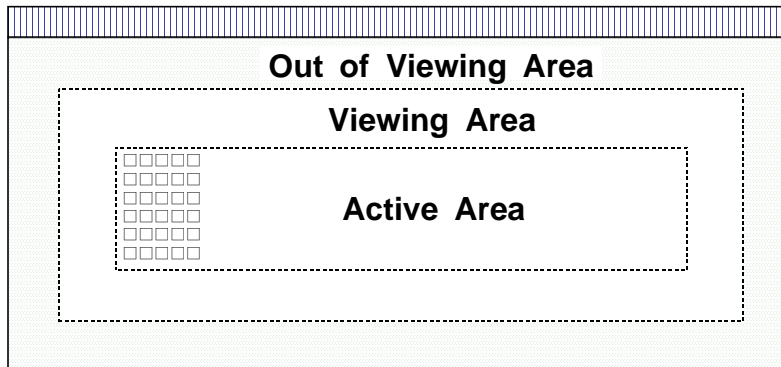

Defect in "Out of View Area" Zone should not be judged.

11-3. Inspection Item

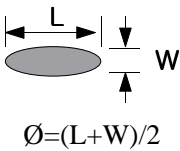
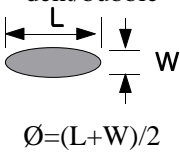
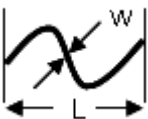
No.	Item	Criterion for Defects	Defect Type									
1	No Display	disallowance	Major									
2	Irregular operating	disallowance	Major									
3	Line defect	disallowance (Vertical line/ Horizontal line / Periodical line)	Major									
4	Foreign material  $\varnothing = (L+W)/2$	<table border="1"> <thead> <tr> <th>Size \varnothing (mm)</th> <th>Acceptable number</th> </tr> </thead> <tbody> <tr> <td>$\varnothing \leq 0.1$</td> <td>Ignore</td> </tr> <tr> <td>$0.1 < \varnothing \leq 0.20$</td> <td>1</td> </tr> <tr> <td>$0.20 < \varnothing$</td> <td>0</td> </tr> </tbody> </table>	Size \varnothing (mm)	Acceptable number	$\varnothing \leq 0.1$	Ignore	$0.1 < \varnothing \leq 0.20$	1	$0.20 < \varnothing$	0	Minor	
Size \varnothing (mm)	Acceptable number											
$\varnothing \leq 0.1$	Ignore											
$0.1 < \varnothing \leq 0.20$	1											
$0.20 < \varnothing$	0											
5	Dark Dot/Bright Dot	<table border="1"> <thead> <tr> <th>Defect mode</th> <th>Acceptable number</th> </tr> </thead> <tbody> <tr> <td>Bright dot</td> <td>0</td> </tr> <tr> <td>Dark dot</td> <td>2</td> </tr> <tr> <td>Total dot defect</td> <td>2</td> </tr> </tbody> </table>	Defect mode	Acceptable number	Bright dot	0	Dark dot	2	Total dot defect	2	Minor	
Defect mode	Acceptable number											
Bright dot	0											
Dark dot	2											
Total dot defect	2											
6	Polarizer dent/bubble  $\varnothing = (L+W)/2$	<table border="1"> <thead> <tr> <th>Size \varnothing (mm)</th> <th>Acceptable number</th> </tr> </thead> <tbody> <tr> <td>$\varnothing \leq 0.1$</td> <td>Ignore</td> </tr> <tr> <td>$0.1 < \varnothing \leq 0.3$</td> <td>3</td> </tr> <tr> <td>$0.3 < \varnothing$</td> <td>0</td> </tr> </tbody> </table>	Size \varnothing (mm)	Acceptable number	$\varnothing \leq 0.1$	Ignore	$0.1 < \varnothing \leq 0.3$	3	$0.3 < \varnothing$	0	Minor	
Size \varnothing (mm)	Acceptable number											
$\varnothing \leq 0.1$	Ignore											
$0.1 < \varnothing \leq 0.3$	3											
$0.3 < \varnothing$	0											
7	Scratch on Polarizer (Line shape) 	<table border="1"> <thead> <tr> <th>Width (mm)</th> <th>Length (mm)</th> <th>Acceptable number</th> </tr> </thead> <tbody> <tr> <td>$W \leq 0.05$</td> <td>Ignore</td> <td>Ignore</td> </tr> <tr> <td>$0.05 < W \leq 0.08$</td> <td>$1.0 < L \leq 5.0$</td> <td>1</td> </tr> </tbody> </table>	Width (mm)	Length (mm)	Acceptable number	$W \leq 0.05$	Ignore	Ignore	$0.05 < W \leq 0.08$	$1.0 < L \leq 5.0$	1	Minor
Width (mm)	Length (mm)	Acceptable number										
$W \leq 0.05$	Ignore	Ignore										
$0.05 < W \leq 0.08$	$1.0 < L \leq 5.0$	1										

SAMSUNG SMD CO., LTD.(All Rights Reserved).

■ Inspection criterion (Continued)

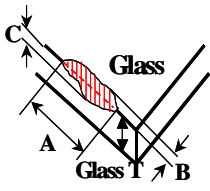
8	<p>Glass side/coner Crack</p> 	<table border="1"> <thead> <tr> <th>Item</th> <th>Size</th> </tr> </thead> <tbody> <tr> <td>A</td> <td>MAX 5.0mm</td> </tr> <tr> <td>B</td> <td>MAX 0.5mm</td> </tr> <tr> <td>C</td> <td>$\leq t$ (t: Thickness of glass)</td> </tr> </tbody> </table>	Item	Size	A	MAX 5.0mm	B	MAX 0.5mm	C	$\leq t$ (t: Thickness of glass)	Minor
		Item	Size								
		A	MAX 5.0mm								
		B	MAX 0.5mm								
C	$\leq t$ (t: Thickness of glass)										
9	Glass crack (Progressive)	disallowance	Major								
10	Surface Stain	Stain which can not clean on the display surface by using soft cloth and wiping gently.	Minor								

※ Visual Inspection Condition ; 250cd/m² , 150± 50 lux

※ If not issued from the customer site or not described above , SMD follows internal guide line.

SAMSUNG SMD CO., LTD.(All Rights Reserved).

12. Reliability

12-1 Items of reliability

: All test result of items should be judged in 2 hours recovery time at room temperature.

: All environmental operating reliability Item do test rolling pattern as below.

[Note] Brightness condition : 250cd/m²

No	Item	Condition	Criterion
1	High Temperature Operating	70°C 72hrs	After testing,cosmetic and electrical defects should not happen. (spec in)
2	Low Temperature Operating	-30°C 72hrs	
3	High Temperature Storage	85°C 72hrs	
4	Low Temperature Storage	-40°C 72hrs	
5	Thermal Shock	- 40°C ↔ 85°C 72hrs	
6	Temperature Humidity Cycle	-10 ~ 65°C, 90~95% 72hrs	
7	Static Electricity	150pF 330Ω	- (Note1) After testing,cosmetic and electrical defects should not happen.
8	Static push	30N / Center point, 2mm/min	After testing,cosmetic and electrical defects should not happen.
9	4 point bending	5mm/min	B10 over 100MPa (face up/down)
10	Peel strength	50mm/min	MIN 5N/cm ↑
11	Module combined (Height storage/Packing vibration/Packing drop)	0.5atm 2hr / 1.047Grms / Z axis(60min)_X,Y axis (30min) / 1corner, 3edge, 6face	After testing,cosmetic and electrical defects should not happen.

SAMSUNG SMD CO., LTD.(All Rights Reserved).

Doc. No.:
AMS369FG06-0

TITLE : 3.7" Visual WVGA 480*800
AMOLED

Rev. : 5.0

26/46

Note 1 Temperature Humidity Cycle Test

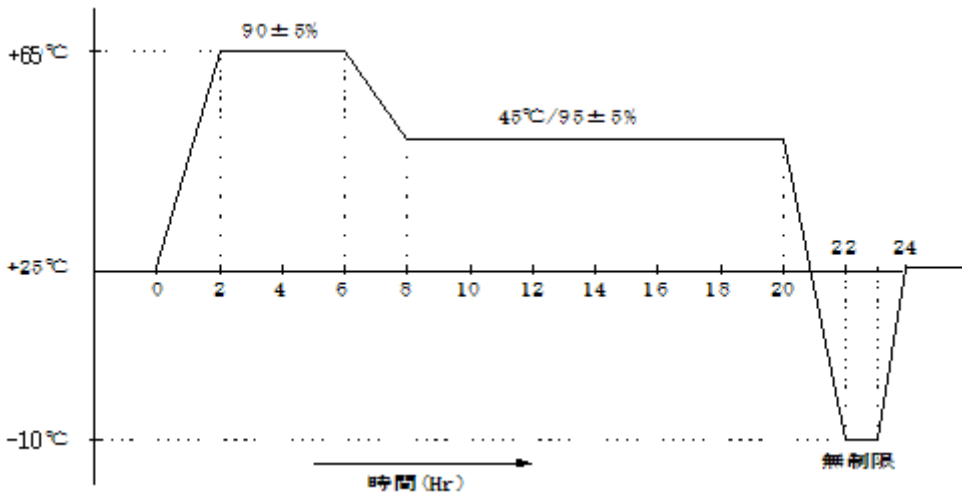

Note 2 ESD

In case of malfunction defect caused by ESD damage,if it would be recovered ㄙ normal state after resetting,it would be judged as a good part.

13. Handling Precautions

13-1. Mounting Method

The AMOLED panel of SAMSUNG SMD CO.,LTD. module consists of two slim glasses with polarizer which can easily get damaged. Since the module is constructed as to be fixed by utilizing fitting holes in the printed circuit board. Extreme care should be used when handling the AMOLED modules.

13-2. Caution of AMOLED Handling and Cleaning

When cleaning the display surface, use soft cloth solvent as recommended below and wipe gently.

- Ⓞ Isopropyl alcohol
- Ⓞ Ethyl alcohol
- Ⓞ Trichlorotrifloroethane

Do not wipe the display surface with dry or hard materials that will damage the polarizer surface. Do not use the following solvent.

- Ⓞ Water
- Ⓞ Ketone
- Ⓞ Aromatics

Do not wipe ITO pad area with the dry or hard materials that will damage the ITO patterns.

Do not use the following solvent on the pad and prevent it from being contaminated.

- Ⓞ HCFC
- Ⓞ Soldering flux
- Ⓞ Chlorine(Cl), Sulfur(S)
- Ⓞ Spittle, FingerprintIf

If the product is not wrapped with a desiccant added pad, ITO pattern can be damaged by corrosion. SAMSUNG SMD CO.,LTD. suggests wrapping a product with adesiccant unless customers particularly indicate that they do not want it. In case ITO pattern corrodes due to the usage of chlorine, sulfur or customer's mishandling of the product, the responsibility lies with the customer.

13-3. Caution Against Static Charge

For AMOLED module, use C-MOS LSI drivers, therefore we recommend that you ;

Connect any unused input terminal to Vdd or Vss, do not input any signals before power is turned on, and ground your body, work/assembly areas, assembly equipment to protect against static electricity. It could occur static electricity when taping off the film which protects AMOLED.

Against static charge, you should make sure that the product is safe or not by experiment in advance.

13-4. Packing

- Ⓞ The packing principle is that AMOLED module should keep its packing condition at the time of delivery. When storing the AMOLED after unpacking, note the followings.
- Ⓞ AMOLED module is consisted of GLASS and assemblies. It should avoid pressure, strong impact, and being dropped from a height.

SAMSUNG SMD CO., LTD.(All Rights Reserved).

Doc. No.:
AMS369FG06-0

TITLE : 3.7" Visual WVGA 480*800
AMOLED

Rev. : 5.0

28/46

- ⊙ To prevent modules from degradation, do not operate or store them in a place where they are directly exposed to sunlight or high temperature/humidity.

13-5. Caution for Operation

- ⊙ If you do not follow normal POWER ON , OFF sequence or abnormal operating, then AMOLED module can be damaged electro-optically and does not recover.
- ⊙ Response time may extremely delay at a temperature lower than operating range, AMOLED does not normally operate at a high temperature. But this may recover at a proper temperature.
- ⊙ When you set optimal operating voltage to AMOLED module, you can see the optimal contrast of AMOLED. So, add voltage controllable function at SET Module.
- ⊙ AMOLED module may not display normally when twisting power or pressing power is added. Therefore you should secure AMOLED module maximum thickness at set assembly not to have any pressure affect AMOLED module.
- ⊙ Electro-chemical reaction may occur when there is humidity on pad, therefore, you should use AMOLED Module below maximum operating humidity.
- ⊙ AMOLED Module Power Vdd should be designed to protect surge current at SET Module.
- ⊙ You should not damage connector and cable for AMOLED module assembly by force folding or by applying extreme power.
- ⊙ AMOLED may not display normally when it is interfered by surrounding elements, therefore you should consider setting design not to damage AMOLED module by surrounding elements.
- ⊙ To satisfy EMI standards, you should plan your design after considering emitting energy.
- ⊙ We can not guarantee display characteristics outside viewing area, therefore your set window should be fixed into viewing area.
- ⊙ Image-sticking may occur if AMOLED displays same image for a long time, so you need to make a change for AMOLED.

13-6. Storage

- ⊙ Place in a dark place where neither exposure to direct sunlight or any fluorescent light is permitted and keep at room temperature & room humidity.
- ⊙ Store with no contact with polarizer surface.
[It is recommended to store them as they have been contained in the inner container when we delivered them.]

13-7. Safety Precautions

- ⊙ Disassembly or modification may cause electric shock, damages to sensitive part inside of the AMOLED module, dust adhesion, or scratches on the display part.
- ⊙ In the event that the contents of AMOLED module are on skin, wipe them with a paper towel or gauge and wash the part well, and receive medical attention if necessary.
- ⊙ Do not use the AMOLED module for the special purpose besides display units.

SAMSUNG SMD CO., LTD.(All Rights Reserved).

Doc. No.: AMS369FG06-0	TITLE : 3.7" Visual WVGA 480*800 AMOLED	Rev. : 5.0	29/46
---	--	-------------------	--------------

- Ⓞ Be careful of the glass chips that may cause injury to fingers of skin, when the display part is broken.

13-8. Precautions before Use

You should discuss the following case with SAMSUNG SMD CO., LTD.

- Ⓞ in case of any questions about contents of this "Specification For Approval".
- Ⓞ in case of occurring new problems not mentioned at this "Specification For Approval".
- Ⓞ in case of your request about income inspection specification change.
- Ⓞ in case of occurring new problem at your driving test.

SAMSUNG SMD CO., LTD.(All Rights Reserved).

Doc. No.:
AMS369FG06-0

TITLE : 3.7" Visual WVGA 480*800
AMOLED

Rev. : 5.0

30/46

14-2. FPCB Drawing

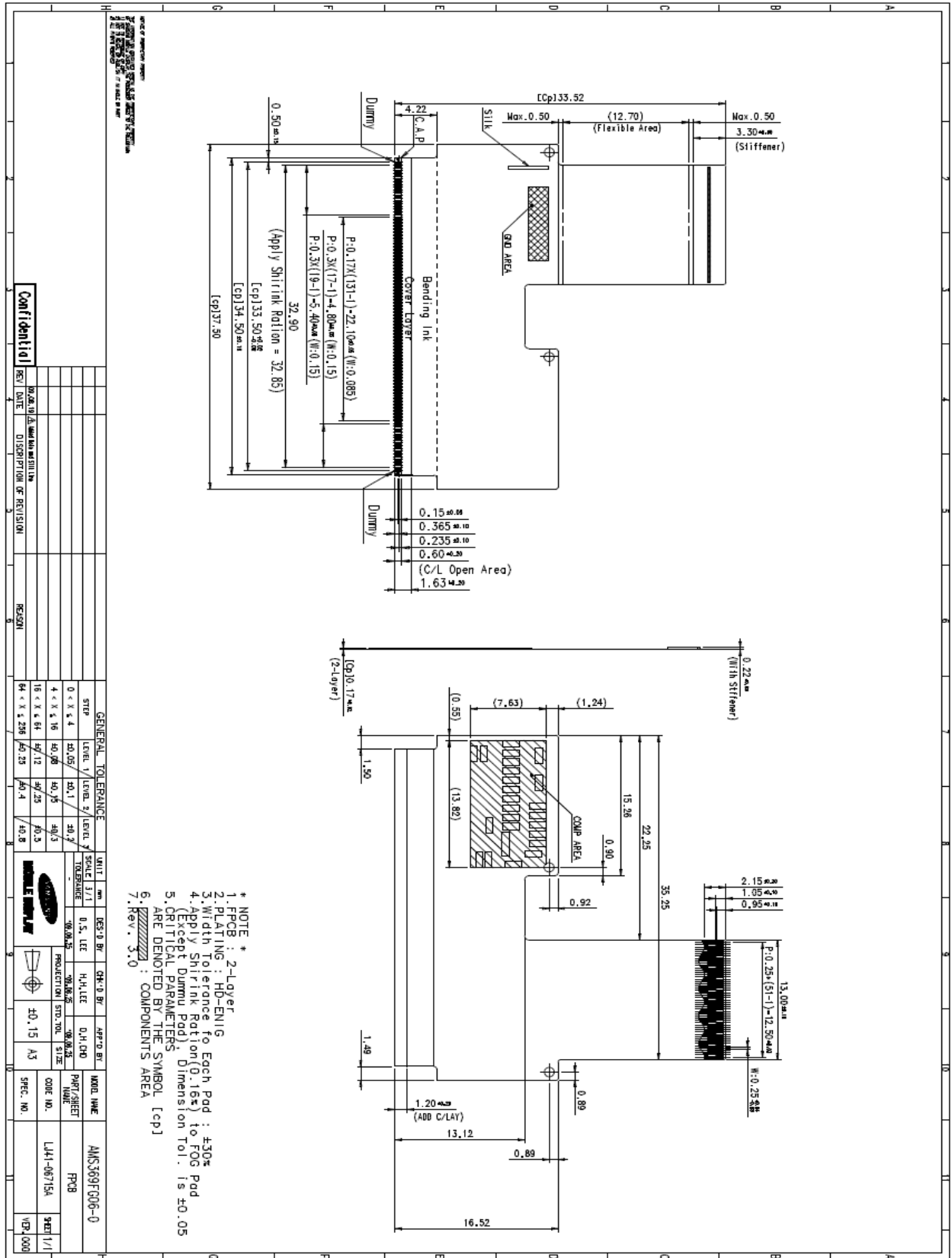

SAMSUNG SMD CO., LTD.(All Rights Reserved).

Doc. No.:
AMS369FG06-0

TITLE : 3.7" Visual WVGA 480*800
AMOLED

Rev. : 5.0

32/46

14-2-1. Schematic Diagram

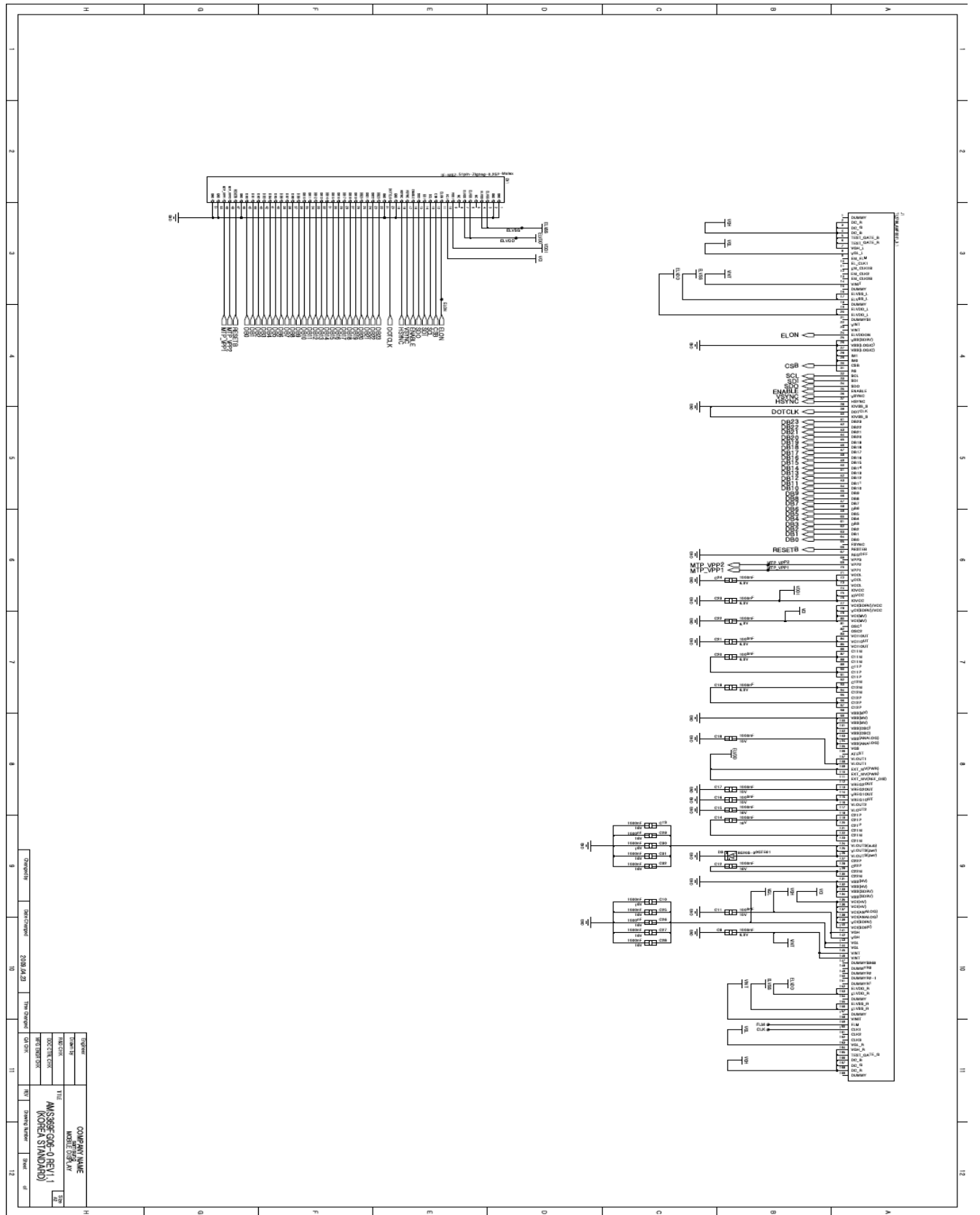

SAMSUNG SMD CO., LTD.(All Rights Reserved).

Doc. No.:
AMS369FG06-0

TITLE : 3.7" Visual WVGA 480*800
AMOLED

Rev. : 5.0

33/46

14-2-2. Electronic Part List

No.	Part name	Reference	Part Description	Qt'y
1	DIODE-SCHOTTKY	D3	DIODE-SCHOTTKY;RB520S-30GTE61,30V,200mA,SOD-523,TP	1
2	CAPACITOR	C9 C19 C20 C21 C22 C23 C24	C-CER,CHIP;1000nF,10%,6.3V,X5R,1005, 1000nF	7
3	CAPACITOR	C11 C16 C17 C18	C-CER,CHIP;1000nF,10%,10V,X5R,TP,1005, 1000nF	4
4	CAPACITOR	C10 C12 C13 C14 C15 C25 C26 C27 C28 C29 C30 C31 C32	C-CER,CHIP;1000nF,10%,16V,X5R,1005, 1000nF	13

SAMSUNG SMD CO., LTD.(All Rights Reserved).

Doc. No.:
AMS369FG06-0

**TITLE : 3.7" Visual WVGA 480*800
AMOLED**

Rev. : 5.0

34/46

14-3. Packing specification

14-3-1. Packing a Carton Box (C-Type)

Part	Code	Quantity	Module (Panel)
Tray	LJ69-02414A	21 * 2	10 / Tray
Cover Tray	LJ69-02414A	2 EA	0 / Tray
Packing-Bag	6902-001053	2 EA	10*21/ Bag
Divider	LJ69-02093A	1 EA	-
Box-Carton	LJ69-02107A	1 EA	420 / Box-Carton

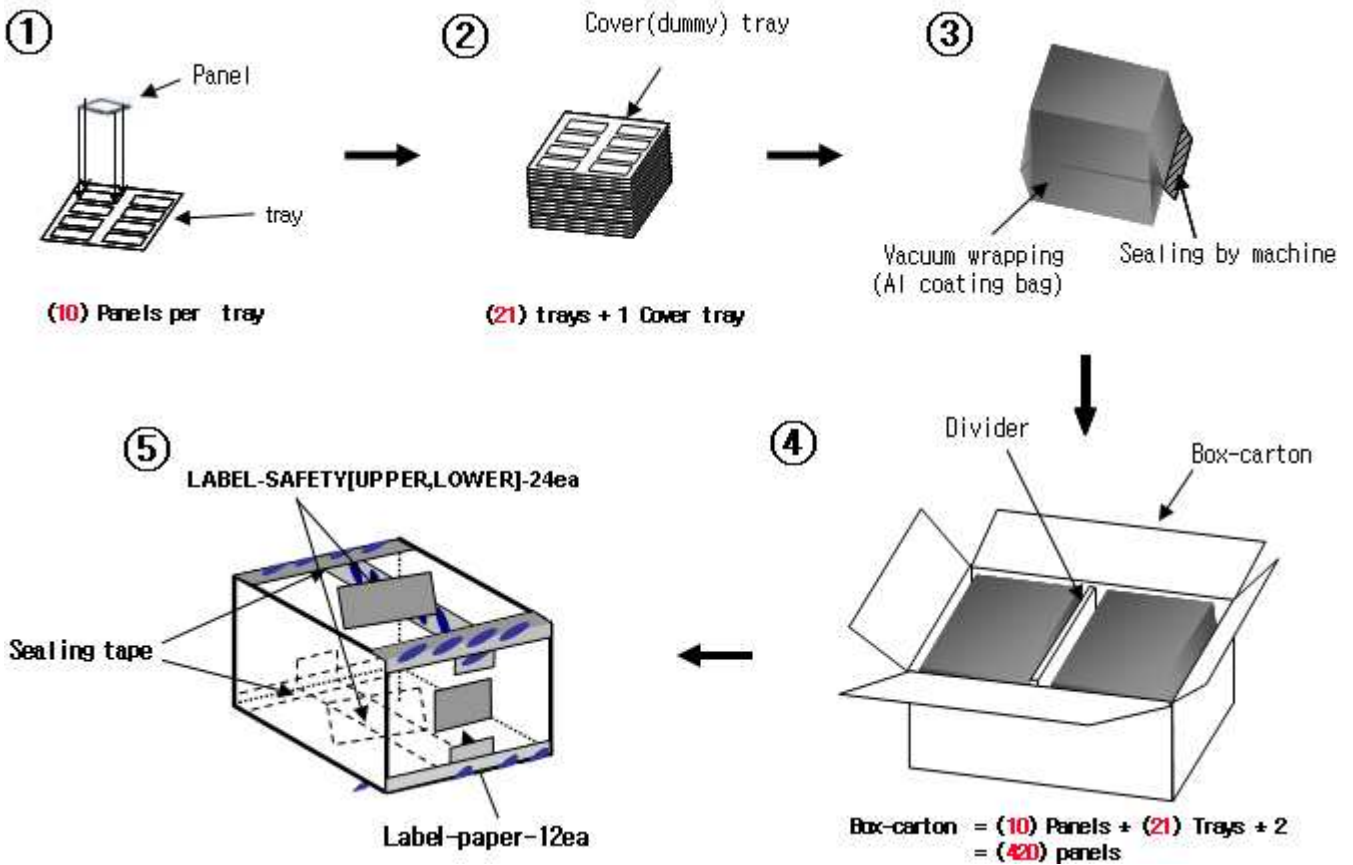

SAMSUNG SMD CO., LTD.(All Rights Reserved).

Note

- (1) Total : Box-carton approx. : (00)kg
- (2) Size :583(W) x 388(D) x 210(H)
- (3) Place the panels in the tray facing up direction.
- (4) Stack the trays and cover (dummy) tray.
- (5) Wrap the Al coating bag by vacuum sealing machine.
- (6) Put the bags in the box-carton with divider.
- (7) Seal the box-carton and affix the label-safety.

※ Packing spec. for small quantities

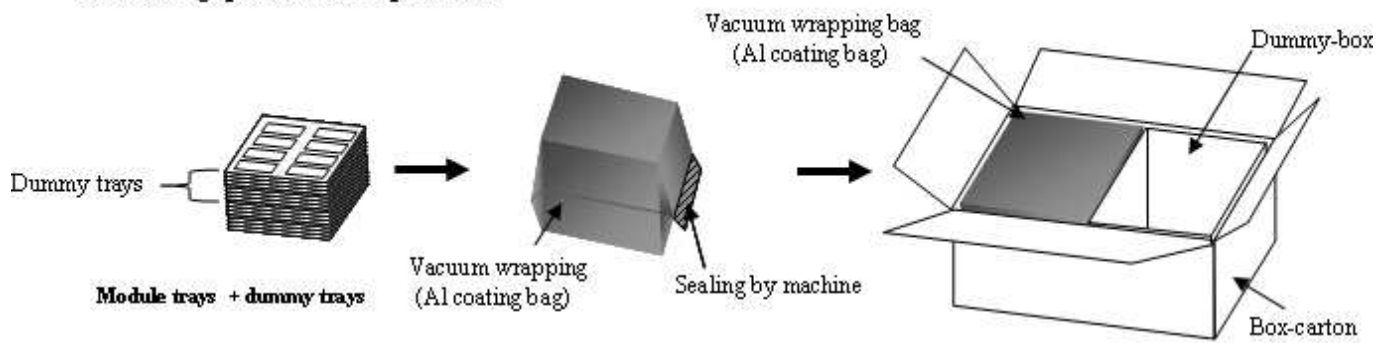

Note

- (1) When package quantity is small, panels containing trays are stacked the bottom, and dummy trays are stacked at the top of package, then wrap the Al coating bag by vacuum sealing machine
- (2) When only one tray bag (Vacuum wrapping bag) is available, dummy box is inserted into the vacant space

SAMSUNG SMD CO., LTD.(All Rights Reserved).

14-3-2. Packing a Pallet Box

Part	Quantity
Pallet	1 EA
Sleeve Bottom	1 EA
Sleeve Box	1 EA
Sleeve Cap	1 EA

①

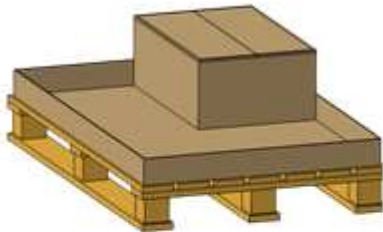

- Load sleeve bottom on a pallet

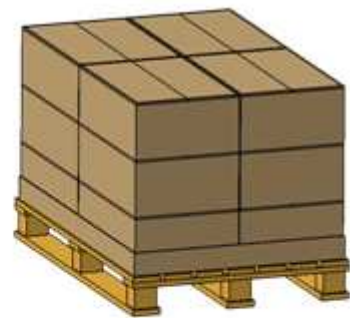

- Load **12EA** carton boxes

③

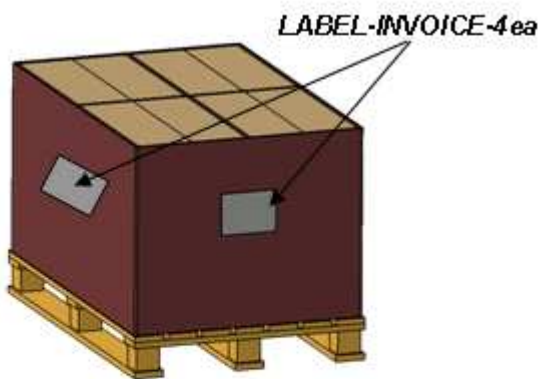

- Cover a packing box

④

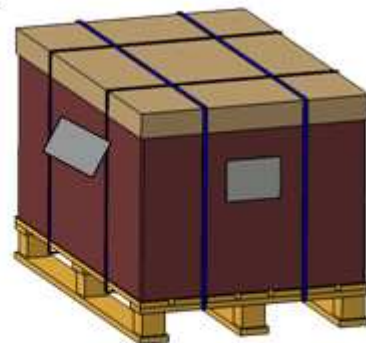

- Cover a sleeve cap
- Taping and Wrapping
- Label-Invoice 4EA
- Label-safety 24EA

SAMSUNG SMD CO., LTD.(All Rights Reserved).

14-3.3. Packing tray drawing

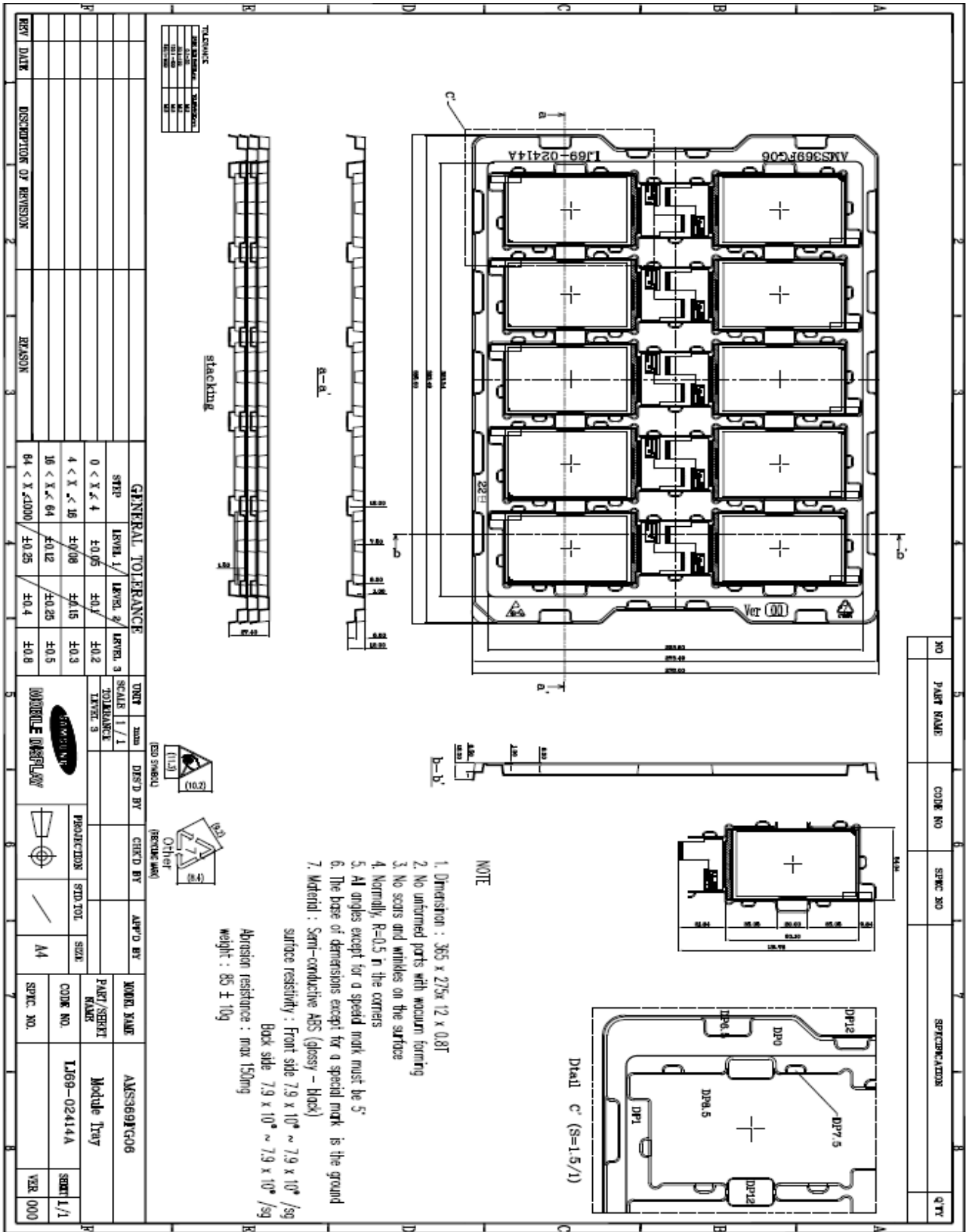

SAMSUNG SMD CO., LTD.(All Rights Reserved).

Doc. No.:
AMS369FG06-0

TITLE : 3.7" Visual WVGA 480*800
AMOLED

Rev. : 5.0

38/46

15. Hazardous material report

Test Report

Applicant Name: SAMSUNG MOBILE DISPLAY
Address: 818, Kachun-Ri, Samnam-Myun, Ulju-Gun, Ulsan, Korea 689-701

Test Report No.: CTK0908-RS-000702
Date of Issue: Aug. 10, 2009

Sample Name: AMS369FG06-0

Receipt Date: Aug. 06, 2009
Test Performing Date: Aug. 10, 2009

Test Performed: CTK Co., Ltd. tested the sample and item(s) which were selected by applicant with following result

Test Results: Refer to following page.

Tested by Jae Won Park, Assistant Manager 
Seung Hyup Baek, Assistant Manager 

CTK Co., Ltd.

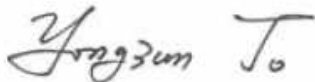

Yongjun Jo / Lab. Manager

SAMSUNG SMD CO., LTD.(All Rights Reserved).

Doc. No.:
AMS369FG06-0

TITLE : 3.7" Visual WVGA 480*800
AMOLED

Rev. : 5.0

39/46

1) PANEL ASS'Y

Heavy Metals				
Test Items	Unit	Test Results	MDL	Test Methods
Pb	mg/kg	N.D	5.0	IEC 62321
Cd		N.D	0.5	
Hg		N.D	1.0	
Cr ⁶⁺		N.D	0.2	



Flame Retardants					
	Test Items	Unit	Test Results	MDL	Test Methods
PBBs	Bromobiphenyl	mg/kg	N.D	1.0	IEC 62321
	Dibromobiphenyl		N.D	1.0	
	Tribromobiphenyl		N.D	1.0	
	Tetrabromobiphenyl		N.D	1.0	
	Pentabromobiphenyl		N.D	1.0	
	Hexabromobiphenyl		N.D	1.0	
	Heptabromobiphenyl		N.D	1.0	
	Octabromobiphenyl		N.D	1.0	
	Nonabromobiphenyl		N.D	1.0	
	Decabromobiphenyl		N.D	1.0	
PBDEs	Bromodiphenyl ether	mg/kg	N.D	1.0	IEC 62321
	Dibromodiphenyl ether		N.D	1.0	
	Tribromodiphenyl ether		N.D	1.0	
	Tetrabromodiphenyl ether		N.D	1.0	
	Pentabromodiphenyl ether		N.D	1.0	
	Hexabromodiphenyl ether		N.D	1.0	
	Heptabromodiphenyl ether		N.D	1.0	
	Octabromodiphenyl ether		N.D	1.0	
	Nonabromodiphenyl ether		N.D	1.0	
	Decabromodiphenyl ether		N.D	1.0	

SAMSUNG SMD CO., LTD.(All Rights Reserved).

Doc. No.: AMS369FG06-0	TITLE : 3.7" Visual WVGA 480*800 AMOLED	Rev. : 5.0	40/46
----------------------------------	---	-------------------	--------------

- PANEL ASS'Y

Halogen Contents				
Test Items	Unit	Test Results	MDL	Test Methods
Chlorine (Cl)	mg/kg	1.5×10 ²	30	EN 14582_IC
Bromine (Br)		N.D	30	EN 14582_IC

SAMSUNG SMD CO., LTD.(All Rights Reserved).

2) BEZEL

Heavy Metals					
Test Items	Unit	Test Results	MDL	Test Methods	
Pb	mg/kg	N.D	5.0	IEC 62321	
Cd		N.D	0.5		
Hg		N.D	1.0		
Cr ⁶⁺		N.D	0.2		
Flame Retardants					
Test Items		Unit	Test Results	MDL	Test Methods
PBBs	Bromobiphenyl	mg/kg	N.A	1.0	IEC 62321
	Dibromobiphenyl		N.A	1.0	
	Tribromobiphenyl		N.A	1.0	
	Tetrabromobiphenyl		N.A	1.0	
	Pentabromobiphenyl		N.A	1.0	
	Hexabromobiphenyl		N.A	1.0	
	Heptabromobiphenyl		N.A	1.0	
	Octabromobiphenyl		N.A	1.0	
	Nonabromobiphenyl		N.A	1.0	
	Decabromobiphenyl		N.A	1.0	
PBDEs	Bromodiphenyl ether	mg/kg	N.A	1.0	IEC 62321
	Dibromodiphenyl ether		N.A	1.0	
	Tribromodiphenyl ether		N.A	1.0	
	Tetrabromodiphenyl ether		N.A	1.0	
	Pentabromodiphenyl ether		N.A	1.0	
	Hexabromodiphenyl ether		N.A	1.0	
	Heptabromodiphenyl ether		N.A	1.0	
	Octabromodiphenyl ether		N.A	1.0	
	Nonabromodiphenyl ether		N.A	1.0	
	Decabromodiphenyl ether		N.A	1.0	

SAMSUNG SMD CO., LTD.(All Rights Reserved).

Doc. No.: AMS369FG06-0	TITLE : 3.7" Visual WVGA 480*800 AMOLED	Rev. : 5.0	42/46
----------------------------------	---	-------------------	--------------

3) FPCB, TAPES, FRAME

Heavy Metals					
Test Items	Unit	Test Results	MDL	Test Methods	
Pb	mg/kg	N.D	5.0	IEC 62321	
Cd		N.D	0.5		
Hg		N.D	1.0		
Cr ⁶⁺		N.D	0.2		
Flame Retardants					
Test Items		Unit	Test Results	MDL	Test Methods
PBBs	Bromobiphenyl	mg/kg	N.D	1.0	IEC 62321
	Dibromobiphenyl		N.D	1.0	
	Tribromobiphenyl		N.D	1.0	
	Tetrabromobiphenyl		N.D	1.0	
	Pentabromobiphenyl		N.D	1.0	
	Hexabromobiphenyl		N.D	1.0	
	Heptabromobiphenyl		N.D	1.0	
	Octabromobiphenyl		N.D	1.0	
	Nonabromobiphenyl		N.D	1.0	
	Decabromobiphenyl		N.D	1.0	
PBDEs	Bromodiphenyl ether	mg/kg	N.D	1.0	IEC 62321
	Dibromodiphenyl ether		N.D	1.0	
	Tribromodiphenyl ether		N.D	1.0	
	Tetrabromodiphenyl ether		N.D	1.0	
	Pentabromodiphenyl ether		N.D	1.0	
	Hexabromodiphenyl ether		N.D	1.0	
	Heptabromodiphenyl ether		N.D	1.0	
	Octabromodiphenyl ether		N.D	1.0	
	Nonabromodiphenyl ether		N.D	1.0	
	Decabromodiphenyl ether		N.D	1.0	

SAMSUNG SMD CO., LTD.(All Rights Reserved).

Doc. No.:
AMS369FG06-0

TITLE : 3.7" Visual WVGA 480*800
AMOLED

Rev. : 5.0

43/46

- FPCB, TAPES, FRAME

Halogen Contents				
Test Items	Unit	Test Results	MDL	Test Methods
Chlorine (Cl)	mg/kg	1.0×10 ²	30	EN 14582_IC
Bromine (Br)		N.D	30	EN 14582_IC

* MDL : Method Detection Limit , N.D : Not Detected, N.A : Not Applicable

SAMSUNG SMD CO., LTD.(All Rights Reserved).

Doc. No.: AMS369FG06-0	TITLE : 3.7" Visual WVGA 480*800 AMOLED	Rev. : 5.0	44/46
----------------------------------	---	-------------------	--------------

*** Conductive tape hazardous material report**



TEST REPORT

Applicant : SOLUETA CO., LTD.
Address : 5B-BL, Wonsi-dong, Danwon-gu,
Ansan-city, Gyeonggi-do, 425-851 Korea

Page: 1 of 5
Date: Jul. 27, 2009

Report No. RT09R-S3296-002-E1

Sample Description : The following submitted sample(s) said to be:-

Name/Type of Product : Conductive fabric
Sample ID No. : RT09R-S3296-002
Item No. : W, WR, WD, WPD, WM, PW series
Manufacturer/Vender : SOLUETA CO., LTD.

Sample received : Jul. 21, 2009
Testing Date : Jul. 21, 2009 - Jul. 27, 2009
Testing Laboratory : Intertek Testing Center
Testing Environment : Temperature : (24 ± 2) °C, Humidity : (60 ± 5) % R.H.

Test Type : RoHS wet chemical analysis
Test Method(s) : Please see the following page(s).
Test Result(s) : Please see the following page(s).

* Note 1 : The test results presented in this report relate only to the object tested.
* Note 2 : This report shall not be reproduced except in full without the written approval of the testing laboratory.
* Note 3 : The item no. is assigned by client and indicated according to their requirements and guarantee letter.

Approved by,

Jade Jang / Lab. Technical Manager

Authorized by,

Bo Park / Lab. General Manager

This Test Report is issued by the Company subject to its Terms and Conditions of Business printed overleaf. Attention is drawn to the limitations of liability, indemnification and jurisdictional issues defined therein. This Test Report shall not be reproduced, except in full, without prior written consent of the Company.

Intertek Testing Center

Seoul Office : Tel : 02-2109-1250 Fax : 02-2109-1259 Gumi Office : Tel : 054-460-7647 Fax : 054-460-7657 Web Site : www.intertek.com
Seoul Lab. : #709, 7Fl, Ace Techno Tower V, 197-22, Guro-3Dong, Guro-Gu, Seoul 152-766 Korea Tel : 02-2109-1260 Fax : 02-2109-1258
Ulsan Lab. : #940-2, Yangseon-Il, Chungjang-Myun, Ulsan-Gun, Ulsan 689-865 Korea Tel : 052-257-6754 Fax : 052-275-6702

SAMSUNG SMD CO., LTD.(All Rights Reserved).

Doc. No.: AMS369FG06-0	TITLE : 3.7" Visual WVGA 480*800 AMOLED	Rev. : 5.0	45/46
----------------------------------	--	-------------------	--------------



TEST REPORT

Page: 2 of 5
Date: Jul. 27, 2009

Report No. RT09R.S3296-002-E1
Sample ID No. : RT09R.S3296-002
Sample Description : Conductive fabric

Test Items	Unit	Test Method	MDL	Results
Cadmium (Cd)	µg/kg	With reference to IEC 62321 Edition 1.0 : 2008, by acid digestion and determined by ICP-OES	0.5	N.D.
Lead (Pb)	µg/kg		5	N.D.
Mercury (Hg)	µg/kg		2	N.D.
Hexavalent Chromium (Cr ⁶⁺) (For non-metal)	µg/kg	With reference to IEC 62321 Edition 1.0 : 2008, by alkaline digestion and determined by UV-VIS Spectrophotometer	1	N.D.
Polybrominated Biphenyl (PBBs)				
Monobromobiphenyl	µg/kg	With reference to IEC 62321 Edition 1.0 : 2008, by solvent extraction and determined by GC/MS	5	N.D.
Dibromobiphenyl	µg/kg		5	N.D.
Tribromobiphenyl	µg/kg		5	N.D.
Tetrabromobiphenyl	µg/kg		5	N.D.
Pentabromobiphenyl	µg/kg		5	N.D.
Hexabromobiphenyl	µg/kg		5	N.D.
Heptabromobiphenyl	µg/kg		5	N.D.
Octabromobiphenyl	µg/kg		5	N.D.
Nonabromobiphenyl	µg/kg		5	N.D.
Decabromobiphenyl	µg/kg		5	N.D.
Polybrominated Diphenyl Ether (PBDEs)				
Monobromodiphenyl ether	µg/kg	With reference to IEC 62321 Edition 1.0 : 2008, by solvent extraction and determined by GC/MS	5	N.D.
Dibromodiphenyl ether	µg/kg		5	N.D.
Tribromodiphenyl ether	µg/kg		5	N.D.
Tetrabromodiphenyl ether	µg/kg		5	N.D.
Pentabromodiphenyl ether	µg/kg		5	N.D.
Hexabromodiphenyl ether	µg/kg		5	N.D.
Heptabromodiphenyl ether	µg/kg		5	N.D.
Octabromodiphenyl ether	µg/kg		5	N.D.
Nonabromodiphenyl ether	µg/kg		5	N.D.
Decabromodiphenyl ether	µg/kg		5	N.D.

Tested by : Nikkie Lee, Peter Kim, Ellen Jung, Jessica Kang

Notes : µg/kg = ppm = parts per million
< = Less than
N.D. = Not detected (< MDL)
MDL = Method detection limit



TEST REPORT

Page: 3 of 5
Date: Jul. 27, 2009

Report No. RT09R.S3296-002-E1
Sample ID No. : RT09R.S3296-002
Sample Description : Conductive fabric

Test Items	Unit	Test Method	MDL	Results
Bromine (Br)	µg/kg	With reference to EN 14582, by oxygen combustion with bomb and determined by IC	30	N.D.
Chlorine (Cl)	µg/kg	With reference to EN 14582, by oxygen combustion with bomb and determined by IC	30	N.D.

Tested by : Nikkie Lee

SAMSUNG SMD CO., LTD.(All Rights Reserved).

Doc. No.:
AMS369FG06-0

**TITLE : 3.7" Visual WVGA 480*800
AMOLED**

Rev. : 5.0

46/46