

ECR #	REV. HIST.	DESCRIPTION	APPROVED	DATE
	A	First release	Ion Cenuse	9/8/99

TECHNICAL SPECIFICATION
AA104VB04
10.4-INCH TFT-LCD MODULE
FOR
INDUSTRIAL APPLICATIONS

APPROVALS		DATE	 MITSUBISHI ELECTRIC		
MELA ENG.		SEP. 8 TH , '99	TFT-LCD MODULE 10.4-INCH VGA COLOR AA104VB04		
MELA MKTG.					
MITSUBISHI/ADI					
SIZE	MITSUBISHI ELECTRIC SPECIFICATION		REV.		
A	AA104VB04		A	SHEET	1 OF 21

TABLE OF CONTENTS

PARAGRAPH NUMBER	ITEM	PAGE
	COVER SHEET	1
	TABLE OF CONTENTS	2
1	OVERVIEW	3
2	ABSOLUTE MAXIMUM RATINGS	4
3	ELECTRICAL CHARACTERISTICS	4, 5
4	INTERFACE CONNECTORS PINASSIGNMENT	6, 7
5	INTERFACE TIMING	8, 9, 10
6	BLOCK DIAGRAM	11
7	MECHANICAL SPECIFICATION	12, 13, 14
8	OPTICAL CHARACTERISTICS	15, 16
9	RELIABILITY TEST CONDITIONS	17
10	LIFE TIME OF THE BACKLIGHT LAMP	18
11	INSPECTION STANDARDS	19
12	HANDLING PRECAUTIONS FOR TFT-LCD MODULES	20, 21

1. OVERVIEW

1.1. Description: AA104VB04 is a 10.4-inch color TFT-LCD (Thin Film Transistor Liquid Crystal Display) module composed of LCD panel, driver ICs, control circuit, and backlight. By applying 6 bit digital data 640 x 480, 262K – color images are displayed on the 10.4-inch diagonal screen. Input power voltage is 5.0 V (does not includes power for the backlight). Both 3.3V-CMOS and 5.0V-CMOS voltage levels are acceptable for logic input voltage. Inverter for backlight is not included in this module.

1.2. General specifications summary table:

ITEM	SPECIFICATION
Display Area (mm)	211.2 X 158.4 (10.39-inch diagonal)
Number of Pixels	640(H) X 480(V)
Pixel Pitch (mm)	0.33(H) X 0.33 (V)
Color Pixel Arrangement	RGB Vertical Stripe
Display Mode	Normally White
Number of colors	262K
Wide Viewing Angle Technology	Optical Compensation Film
Optimum Viewing Angle (Contrast Ratio)	12 O'clock
Brightness (cd/m ²)	400
Power Consumption (W)	8.5
Module Size (mm)	243.0(W) X 181.6(H) X 12.2 (D)
Module Weight (g)	530
Backlight Unit	CCFL, Two Lamps, Replaceable

1.3. Product Disclaimer

The LCD products listed in this document are not suitable for safety related applications that do not have redundant back-up system(s). In other words, these LCD products are not designed for use as a single source safety related application, and therefore, are not recommended for applications in which human life and/or environment may be affected in the event of the failure of the LCD product. More specifically, if there is no back-up system or product in place that will continue operating the system, the LCD products should not be used in such things as:

- (i), aircraft navigation or aerospace equipment;
- (ii) nuclear reactor control systems;
- (iii) any application where failure or inaccuracy might cause death or personal injury (e.g., life support systems); or
- (iv) military and submarine critical systems.

The LCD products are designed for typical industrial applications such as, but not are limited to the following: computers, office equipment, industrial controllers, audio and visual equipment, test and measurement devices, communication equipment, point of sale, medical imaging and automotive and various other consumer products. If there are any questions regarding the use, ability or application of these LCD products, please contact an authorized sales representative.

2. ABSOLUTE MAXIMUM RATINGS

2.1. Environmental conditions: humidity $\leq 85\%$ RH, no condensation

2.2. Summary Table:

ITEM	SYMBOL	MIN	MAX	UNIT
Power Supply Voltage for LCD	V_{CC}	-0.3	6.5	V
Operating Temperature	T_{op}	0	50	$^{\circ}C$
Storage Temperature	T_{stg}	-20	60	$^{\circ}C$

3. ELECTRICAL CHARACTERISTICS

3.1. Conditions: TFT-LCD module ambient temperature is $25^{\circ}C$

3.2. Summary table:

ITEM	SYMBOL	MIN	TYP	MAX	UNIT	COMMENTS
Power Supply Voltage for LCD*	V_{CC}	4.75	5	5.25	V	
Power Supply Current for LCD*	I_{CC}		200		mA	
Permissible Input Ripple Voltage	V_{RP}			100	mV _{p-p}	$V_{CC}=+5.0V$
Logic Input Voltage	High	V_{LH}	2.0		V_{CC}	V
	Low	V_{LL}	0.0		0.8	V

Note * : See paragraph 3.4

3.3. Backlight

3.3.1. The table below shows data for one lamp only.

3.3.2. The TFT-LCD module has two identical lamps operated independently.

3.3.3. Operation of both lamps is required in order to meet all the parameters in the AA104VB04 specification.

ITEM	SYMBOL	MIN	TYP	MAX	UNIT
Lamp Voltage	V_L		580		V
Lamp Current	I_L	3.0	6.5 *	7.0	mA
Lamp Starting Voltage	V_S	810			V

Note * : For typical luminance of $400cd/m^2$

SIZE	MITSUBISHI ELECTRIC SPECIFICATION	REV.			
A	AA104VB04	A	SHEET	4	OF 21

3.4. Notes

3.4.1. V_{CC} turn-on conditions :

- $t_1 \leq 10\text{ms}$
- $0 < t_2 \leq 50\text{ms}$
- $0 < t_3 \leq 50\text{ms}$

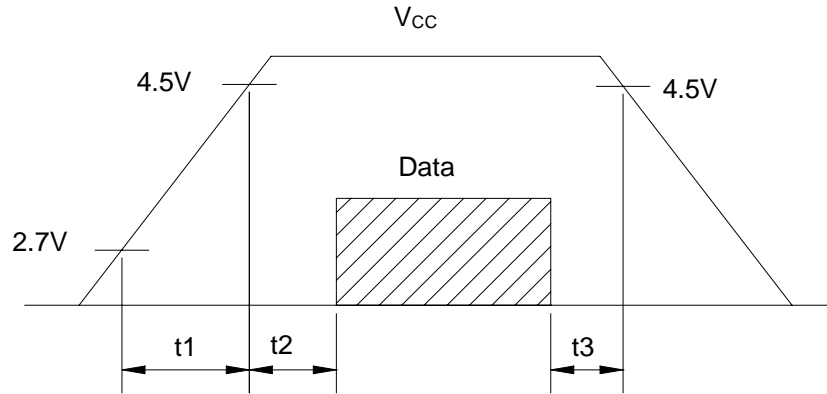

3.4.2. V_{CC} -dip conditions :

- $2.7\text{V} \leq V_{CC} < 4.5\text{V}$ and $t_d \leq 10\text{ms}$
- $V_{CC} < 2.7\text{V}$
- V_{CC} -dip conditions should also follow the V_{CC} turn-on conditions.

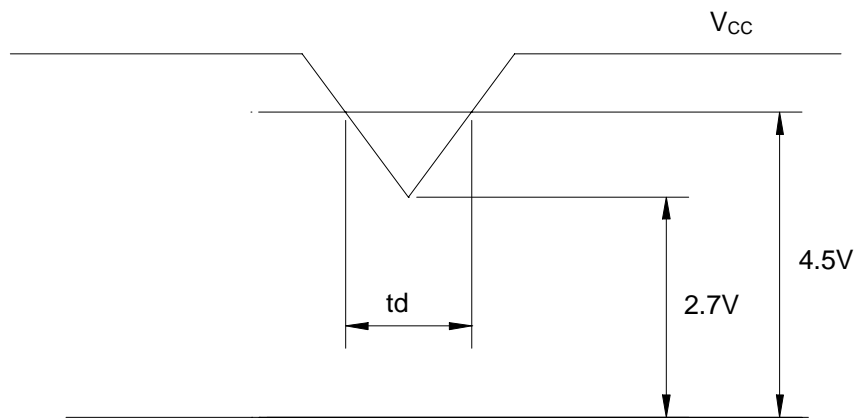

3.4.3. Test condition for I_{CC} Typical:

- 64 gray-bar pattern
- 480 line mode
- $V_{CC} = +5\text{V}$

3.4.4. Test conditions for I_{CC} (MAX) :

- 1 X 1 checkerboard, black and white pattern
- DC input voltage = 4.75V

SIZE	MITSUBISHI ELECTRIC SPECIFICATION	REV.			
A	AA104VB04	A	SHEET	5	OF 21

4. INTERFACE CONNECTORS PIN ASSIGNMENT

- 4.1. Input connector type (See paragraph 6.)
 Input connector CN1: DF9B-31P-1V (Hirose)
 Input mating connector: DF9B-31S-1V (Hirose)
- 4.2. Input connector pin assignment table:

PIN	SYMBOL	FUNCTION
1	GND	Ground*
2	DCLK	Clock signal
3	HD	Horizontal sync signal
4	VD	Vertical sync signal
5	GND	Ground*
6	R0	Red data signal (LSB)
7	R1	Red data signal
8	R2	Red data signal
9	R3	Red data signal
10	R4	Red data signal
11	R5	Red data signal (MSB)
12	GND	Ground*
13	G0	Green data signal (LSB)
14	G1	Green data signal
15	G2	Green data signal
16	G3	Green data signal
17	G4	Green data signal
18	G5	Green data signal (MSB)
19	GND	Ground*
20	B0	Blue data signal (LSB)
21	B1	Blue data signal
22	B2	Blue data signal
23	B3	Blue data signal
24	B4	Blue data signal
25	B5	Blue data signal (MSB)
26	GND	Ground*
27	DENA	Data enable signal
28	V _{CC}	5.0V Power Supply
29	V _{CC}	5.0V Power Supply
30	TEST	This pin should be open. Test signal output for only internal test use.
31	TEST	This pin should be open. Test signal output for only internal test use.

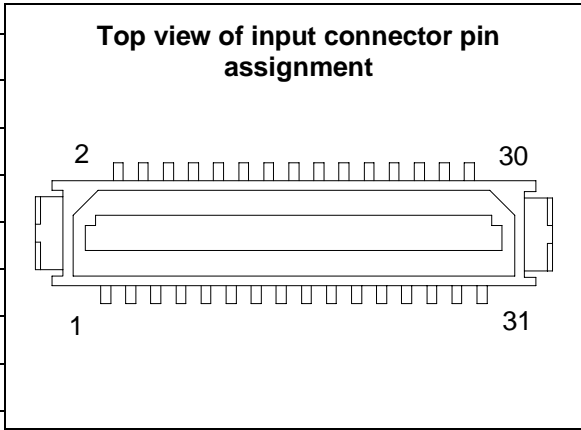

*Note: The metal frame of the TFT-LCD module is connected to ground.

- 4.3. Backlight connector type (See paragraph 6)
 Backlight connector (CN2 and CN3): BHR-02(8.0)VS-1N (JST)
 Backlight mating connector: SM02(8.0)B-BHS (JST)
- 4.4. Backlight connector pin assignment table:

PIN NUMBER	SYMBOL	FUNCTION
1	CTH	VBLH(High voltage)
3	CTL	VBLL(Low voltage)

5. INTERFACE TIMING

5.1. Timing Chart

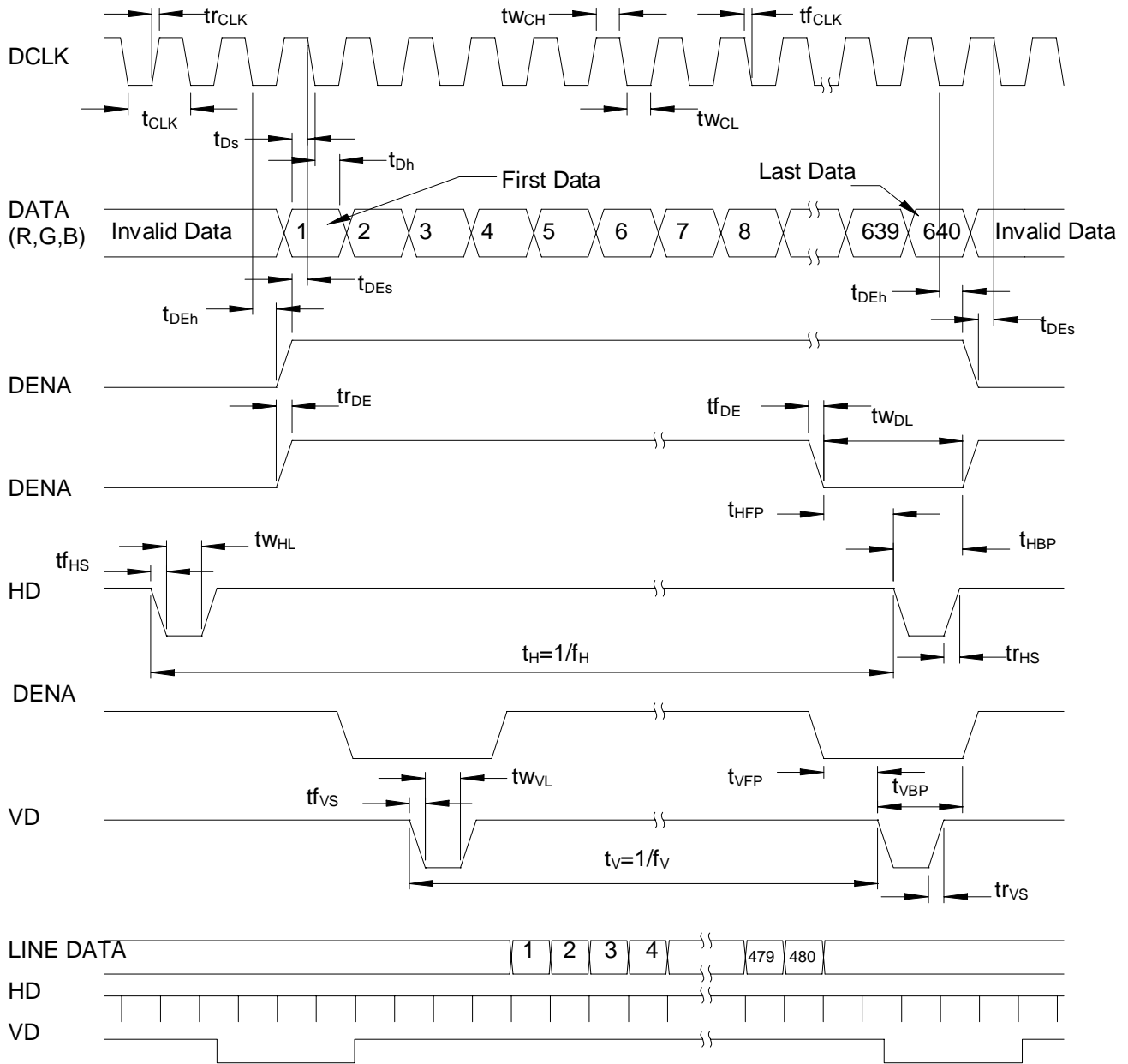

Definition of t_r , t_w and t_f



SIZE	MITSUBISHI ELECTRIC SPECIFICATION	REV.			
A	AA104VB04	A	SHEET	8	OF 21

5.2. Timing Specification

	ITEM	SYMBOL	MIN	TYP	MAX	UNIT
DCLK *	Frequency	f_{CLK}		25	29	MHz
	Period	t_{CLK}	34.5	40		ns
	Width-Low	tw_{CL}	12			ns
	Width-High	tw_{CH}	12			ns
	Rise Time	tr_{CLK}			5	ns
	Fall Time	tf_{CLK}			5	ns
DATA (R, G, B)	Set up Time	t_{Ds}	5			ns
	Hold Time	t_{Dh}	5			ns
DENA	Set up Time	t_{DEs}	5			ns
	Hold Time	t_{DEh}	5			ns
	Low Time	tw_{DL}	90	160	168	t_{CLK}
	Rise Time	tr_{DE}			5	ns
	Fall Time	tf_{DE}			5	ns
	Horizontal Front Porch	t_{HFP}	0	16		t_{CLK}
	Horizontal Back Porch	t_{HBP}	2	144		t_{CLK}
	Vertical Front Porch	t_{VFP}	1	12		t_H
Vertical Back Porch	t_{VBP}	2	33		t_H	
HD *	Frequency	f_H	27	31.6	38	kHz
	Period	t_H	730	800	808	t_{CLK}
	Width Low	tw_{HL}	5	96		t_{CLK}
	Rise Time	tr_{HS}			10	ns
	Fall Time	tf_{HS}			10	ns
VD	Frequency	f_V	55	60.0	70	Hz
	Period	t_V	489	525		t_H
	Width Low	tw_{VL}	3			t_H
	Rise Time	tr_{VS}			10	ns
	Fall Time	tf_{VS}			10	ns

* Note: DCLK and HD should be applied continuously at the input connector of the TFT-LCD module during operation, subject to V_{CC} turn-on conditions.

5.3. Color Data Assignment

COLOR	INPUT DATA	R D A T A						G D A T A						B D A T A					
		R5	R4	R3	R2	R1	R0	G5	G4	G3	G2	G1	G0	B5	B4	B3	B2	B1	B0
		MSB					LSB	MSB					LSB	MSB					LSB
BASIC COLOR	BLACK	0	0	0	0	0	0	0	0	0	0	0	0	0	0	0	0	0	0
	RED(63)	1	1	1	1	1	1	0	0	0	0	0	0	0	0	0	0	0	0
	GREEN(63)	0	0	0	0	0	0	1	1	1	1	1	1	0	0	0	0	0	0
	BLUE(63)	0	0	0	0	0	0	0	0	0	0	0	0	1	1	1	1	1	1
	CYAN	0	0	0	0	0	0	1	1	1	1	1	1	1	1	1	1	1	1
	MAGENTA	1	1	1	1	1	1	0	0	0	0	0	0	1	1	1	1	1	1
	YELLOW	1	1	1	1	1	1	1	1	1	1	1	1	0	0	0	0	0	0
	WHITE	1	1	1	1	1	1	1	1	1	1	1	1	1	1	1	1	1	1
RED	RED(0)	0	0	0	0	0	0	0	0	0	0	0	0	0	0	0	0	0	0
	RED(1)	0	0	0	0	0	1	0	0	0	0	0	0	0	0	0	0	0	0
	RED(2)	0	0	0	0	1	0	0	0	0	0	0	0	0	0	0	0	0	0
	⋮																		
	⋮																		
	RED(62)	1	1	1	1	1	0	0	0	0	0	0	0	0	0	0	0	0	0
	RED(63)	1	1	1	1	1	1	0	0	0	0	0	0	0	0	0	0	0	0
GREEN	GREEN(0)	0	0	0	0	0	0	0	0	0	0	0	0	0	0	0	0	0	0
	GREEN(1)	0	0	0	0	0	0	0	0	0	0	0	1	0	0	0	0	0	0
	GREEN(2)	0	0	0	0	0	0	0	0	0	0	1	0	0	0	0	0	0	0
	⋮																		
	⋮																		
	GREEN(62)	0	0	0	0	0	0	1	1	1	1	1	0	0	0	0	0	0	0
	GREEN(63)	0	0	0	0	0	0	1	1	1	1	1	1	0	0	0	0	0	0
BLUE	BLUE(0)	0	0	0	0	0	0	0	0	0	0	0	0	0	0	0	0	0	0
	BLUE(1)	0	0	0	0	0	0	0	0	0	0	0	0	0	0	0	0	0	1
	BLUE(2)	0	0	0	0	0	0	0	0	0	0	0	0	0	0	0	0	1	0
	⋮																		
	⋮																		
	BLUE(62)	0	0	0	0	0	0	0	0	0	0	0	0	1	1	1	1	1	0
	BLUE(63)	0	0	0	0	0	0	0	0	0	0	0	0	1	1	1	1	1	1

5.3.1. Definitions
 Gray scale: Color (n) → n indicates gray scale level.
 Data: 1=High, 0=Low

6. BLOCK DIAGRAM

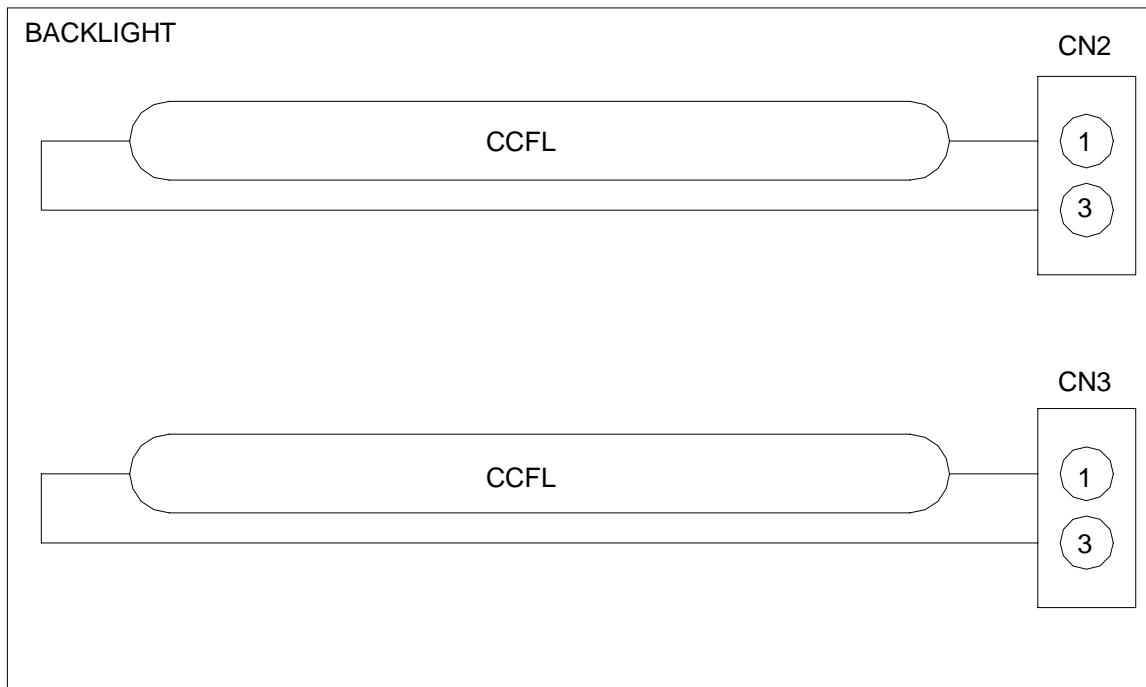
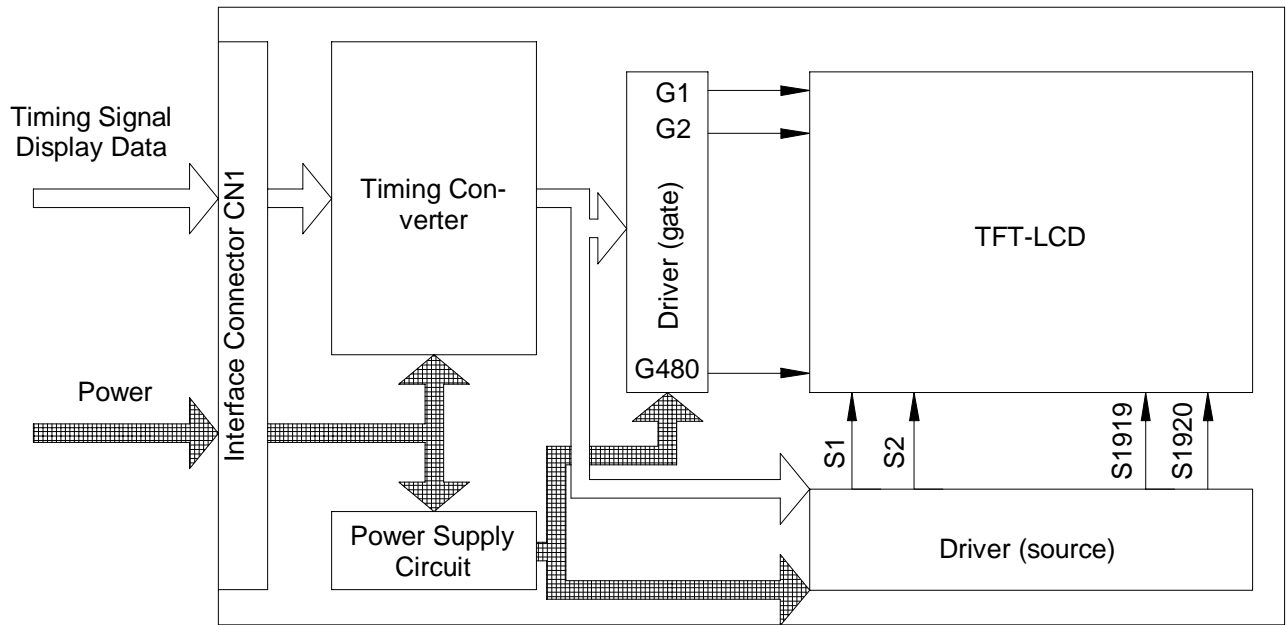

SIZE	MITSUBISHI ELECTRIC SPECIFICATION	REV.			
A	AA104VB04	A	SHEET	11	OF 21

7.1.

MECHANICAL SPECIFICATION
Front Side Drawing

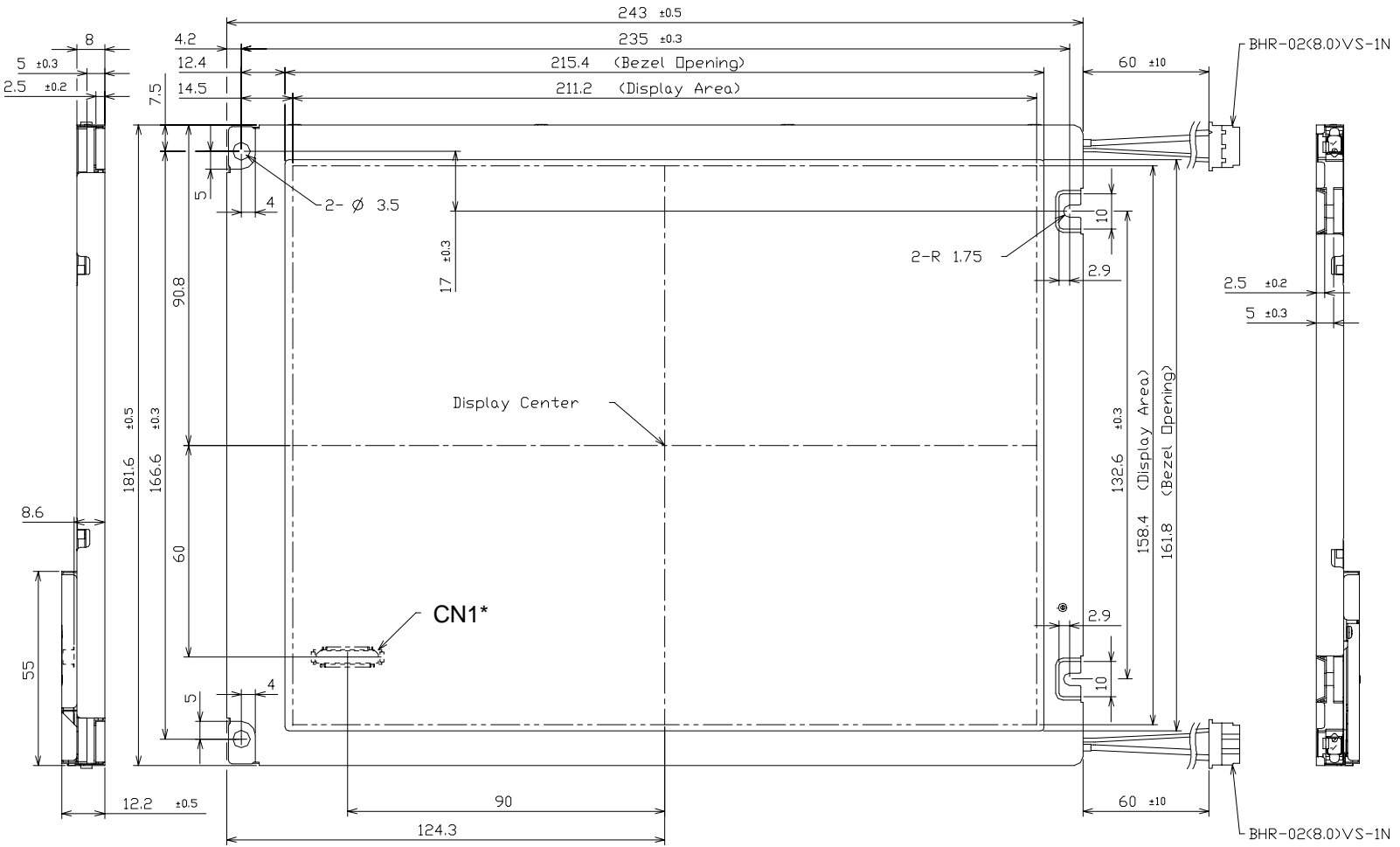

*Note: The connector CN1 is located on the rear side of the TFT-LCD module..
Undefined tolerances are ±0.5mm

SIZE	MITSUBISHI ELECTRIC SPECIFICATION	REV.	SHEET	12	OF	21
A	AA104VB04	A				

7.2. Rear Side Drawing

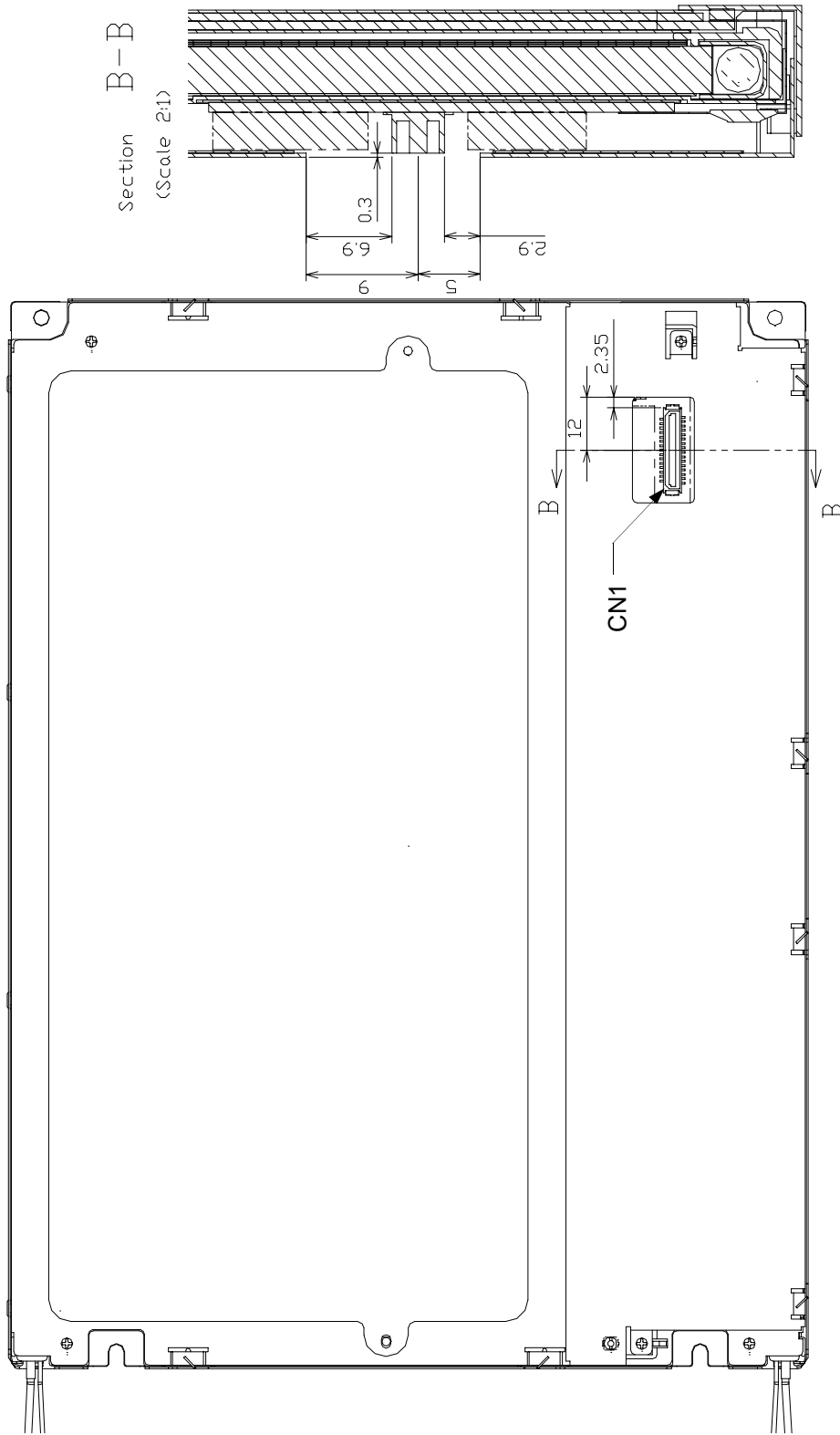

SIZE	MITSUBISHI ELECTRIC SPECIFICATION	REV.			
A	AA104VB04	A	SHEET	13	OF 21

7.3. Scanning direction

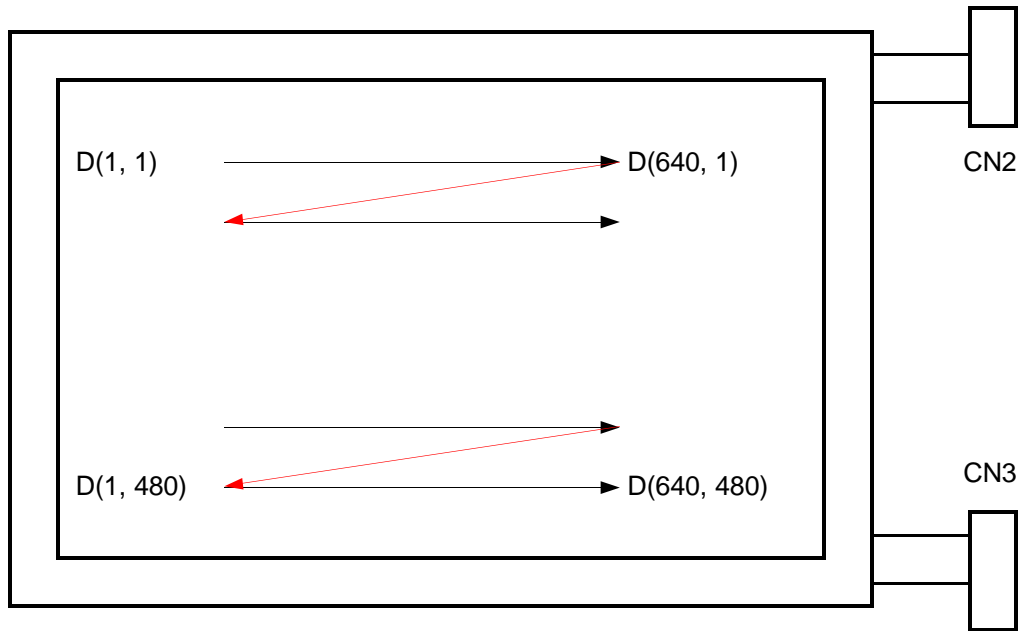

SIZE	MITSUBISHI ELECTRIC SPECIFICATION	REV.				
A	AA104VB04	A	SHEET	14	OF	21

8. OPTICAL CHARACTERISTICS

8.1. Test conditions: $T_a=25^{\circ}\text{C}$, $V_{CC}=5.0\text{V}$, $I_L=6.5\text{mA}$. All measurements made using BM-5A (TOPCON) or LCD-7000 (Otsuka Electronic) in a dark room, under no ambient light conditions.

8.2. Summary table:

ITEM		SYMBOL	CONDITION	MIN	TYP	MAX	UNIT
Contrast	Ratio	CR	$\theta = \phi = 0^{\circ}$	150	300	—	
Luminance		L	$\theta = \phi = 0^{\circ}$	—	400	—	cd/m^2
Response Time		tr	$\theta = \phi = 0^{\circ}$	—	15	—	ms
		tf	$\theta = \phi = 0^{\circ}$	—	35	—	ms
Viewing Angle	Horizontal	ϕ	$\text{CR} \geq 10$	—	-60~60	—	$^{\circ}$
	Vertical	θ		—	-45~55	—	$^{\circ}$
Color Coordinates	Red	X	$\theta = \phi = 0^{\circ}$	0.54	0.57	0.60	—
		y		0.30	0.33	0.36	
	Green	x		0.30	0.33	0.36	
		y		0.49	0.52	0.55	
Blue	x	0.14	0.17	0.20			
	y	0.15	0.18	0.21			
White	x	0.29	0.32	0.35			
	y	0.31	0.34	0.37			

8.3. Definitions

8.3.1. Contrast Ratio CR = ON (White) Luminance / OFF (Black) Luminance

8.3.2. Viewing Angle (θ , ϕ) - See drawing below :

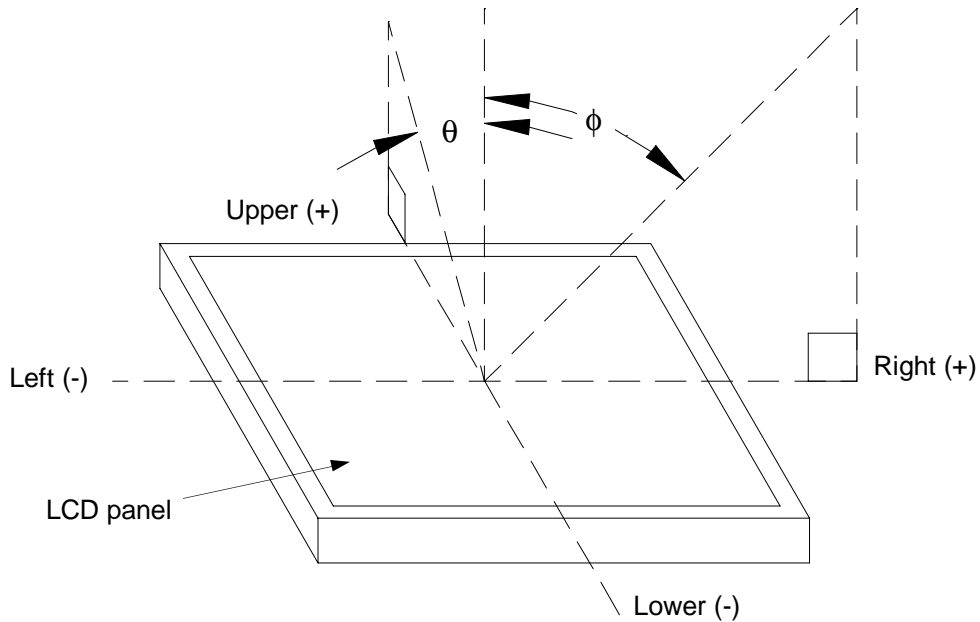

SIZE	MITSUBISHI ELECTRIC SPECIFICATION	REV.			
A	AA104VB04	A	SHEET	15	OF 21

8.3.3. Definition of Response Time t_r and t_f :

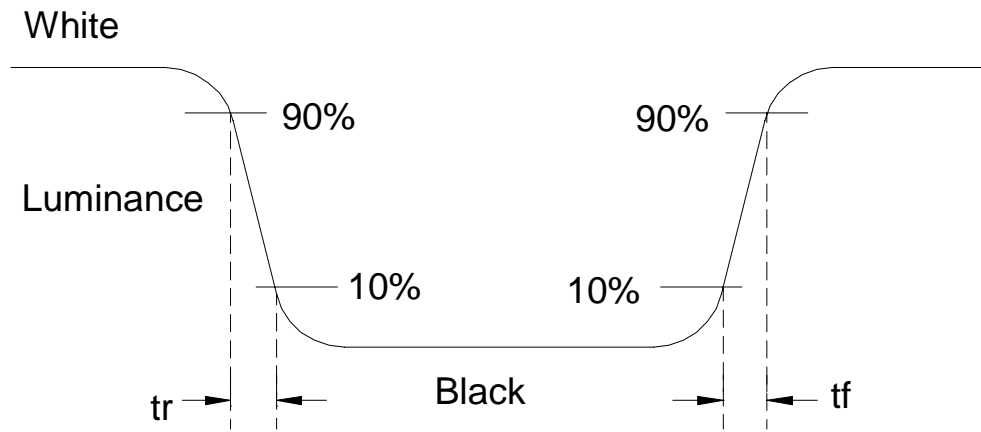

SIZE	MITSUBISHI ELECTRIC SPECIFICATION	REV.		
A	AA104VB04	A	SHEET	16 OF 21

9. RELIABILITY TEST CONDITIONS

9.1. Temperature and Humidity

TEST ITEM	CONDITIONS
High Temperature and High Humidity Operation	40 degree C, 90%RH 500 hours
High Temperature and High Humidity Storage	60 degree C, 90%RH 96 hours
Low Temperature Storage	-20 degree C, 96 hours
Thermal Shock (non-operating)	Between -20 degree C (1 hour) and 60 degree C (1 hour) 5 cycles

9.2. Shock and Vibration

TEST ITEM	CONDITIONS
Shock (non-operating)	Shock level: 1470 m/s (150G) Waveform: half sinusoidal wave, 2 ms ² Number of shocks: one shock input in each direction of three mutually perpendicular axis for a total of six shock inputs
Vibration (non-operating)	Vibration level: 9.8 m/s ² (1.0G) Waveform: sinusoidal Frequency range: 5 to 500 Hz Frequency sweep rate: 0.5 octave/min Duration: one sweep from 5 to 500 to 5Hz in each of three mutually perpendicular axis (total 3hr)

- 9.3. Judgment Standard – Pass/Fail criteria for reliability tests is defined as follow:
Pass: Normal display image with no obvious non-uniformity and no line defect.
Fail : No display image, obvious non-uniformity, or line defect.

SIZE	MITSUBISHI ELECTRIC SPECIFICATION	REV.		
A	AA104VB04	A	SHEET	17 OF 21

10. LIFE TIME OF THE BACKLIGHT LAMP

10.1. Definitions

10.1.1. Lamp end of life is defined as the luminance of it become half of the initial value or lamp does not turn on under 810V at 25°C.

10.1.2. The life time of the backlight lamp depends on the ambient temperature. The life time may be different from the time specified in the table below if the lamp is operated under extreme temperature conditions.

10.2. Summary Table

ITEM	SYMBOL	CONDITION	SPECIFICATION		UNIT
			MIN	TYP	
Life Time	TL	IL=3.0mA, Ta=25°C	50,000	50,000	hour
		IL=6.0mA, Ta=25°C	40,000	50,000	
		IL=7.0mA, Ta=25°C	30,000	40,000	

SIZE	MITSUBISHI ELECTRIC SPECIFICATION	REV.			
A	AA104VB04	A	SHEET	18	OF 21

12. HANDLING PRECAUTIONS FOR TFT-LCD MODULE - Please observe the recommendations included in this paragraph when handling the TFT-LCD modules!

12.1. ASSEMBLY PRECAUTIONS

- 12.1.1. Please use the mounting hole on the module corners for installation and avoid bending or wrenching LCD during assembly process. Do not drop, bend or twist the TFT-LCD module during handling.
- 12.1.2. Guidelines for designing the TFT-LCD module enclosure:
 - 12.1.2.1. Housing case must be designed carefully so as not to put stresses on LCD all sides and not to wrench module. Mechanical stress to the TFT-LCD module may degrade the reliability and overall performances of the display (like brightness uniformity degradation...etc.).
 - 12.1.2.2. Keep sufficient clearance between LCD module back surface and housing when the LCD module is mounted. Approximately 1.0 mm of the clearance in the design is recommended taking into account the tolerance of LCD module thickness and mounting structure height on the housing.
 - 12.1.2.3. When some parts, such as, FPC cable and ferrite plate, are installed underneath the LCD module, still sufficient clearance is required, such as 0.5mm. This clearance is, especially, to be reconsidered when additional parts are inserted for EMI countermeasures.
 - 12.1.2.4. Choose carefully the inverter location to avoid any stress to the lamp cable. The lamp cable also should not interfere with the module installation into the enclosure.
 - 12.1.2.5. Keep sufficient clearance between LCD module and the others components, such as inverter and speaker so as not to interfere with the LCD module. Approximately 1.0 mm of the clearance in the design is recommended.
- 12.1.3. Do not apply pressure or scratch LCD panel surface with anything hard. Do not soil LCD panel surface by touching with bare hands. (Polarizer film, surface of LCD panel is easy to be flawed.)
- 12.1.4. Do not apply pressure on any parts on the rear side such as source TCP, gate TCP, control circuit board and FPCs during handling LCD module. If applying pressure to the TFT-LCD module is unavoidable, handle the LCD module with care not to damage them.
- 12.1.5. Wipe out LCD panel surface with absorbent cotton or soft cloth to clean the surface.
- 12.1.6. Wipe out immediately any liquids which may have accidentally being sprayed on LCD panel surface. Droplets on the LCD panel surface may alter the quality of the image.
- 12.1.7. Do not disassemble the TFT-LCD module for any reasons. By doing so you void the warranty of the TFT-LCD module and is very likely that the performances will be degraded considerably.
- 12.1.8. Do not touch metal frames with bare hands and soiled gloves. If fingerprints or dirt are not cleaned immediately with solvent it is very likely that permanent marks will be left on the metal surfaces.
- 12.1.9. Disconnect the lamp wires before handling the inverter otherwise is possible to damage the lamp and or the lamp wires by pulling it together with the inverter.

12.2. OPERATING PRECAUTIONS

- 12.2.1. Turn off the power supply before connecting and disconnecting signal input cable.
- 12.2.2. Do not change the setting of the adjustable resistors on TFT-LCD module subassemblies. The adjustable resistors are properly set at the factory and any deviation from the factory setting will compromise the performances of the TFT-LCD module.
- 12.2.3. When evaluating the optical characteristics of the display please note that will take longer time for the backlight to stabilize if the ambient temperature is at the lower end of the temperature range.
- 12.2.4. Sudden changes of the ambient temperature may cause condensation on various surfaces of the TFT-LCD module and degrade the overall performances until the surfaces become dry again.
- 12.2.5. Follow-up the general safety rules applying to generic electronic products.

SIZE	MITSUBISHI ELECTRIC SPECIFICATION	REV.			
A	AA104VB04	A	SHEET	20	OF 21

12.3. PRECAUTIONS WITH ELECTRONICS

- 12.3.1. This LCD module uses CMOS integrated circuits and other components subject to be affected by electrostatic discharges. Use ESD protection equipment and follow all ESD safety procedures when handling the TFT-LCD modules.
- 12.3.2. Please remove protection film very slowly from the surface of LCD module to prevent from high level electrostatic discharges. It is recommended to lift the protection film starting from the corner of the glass in proximity of the source and gate PWB ending at the corner of the glass furthest away from the electronics.

12.4. STORAGE PRECAUTIONS

- 12.4.1. When you store LCDs for a long time, it is recommended to keep the temperature between 0°C ~ 40 °C without the exposure of sunlight and to keep the humidity less than 90%RH.
- 12.4.2. Do not leave the LCDs in the environment of high humidity and high temperature such as 60°C 90%RH.
- 12.4.3. Do not expose the TFT-LCD modules to temperatures below –20°C.

12.5. SAFETY PRECAUTIONS

- 12.5.1. When disposing LCDs it is recommended to break them into pieces. The broken pieces should be washed with solvents such as acetone and ethanol. The residual solvent from this process should be burned.
- 12.5.2. If any liquid leaks out of a damaged glass cell and comes in contact with the hands, wash it off thoroughly with soap and water.

12.6. OTHERS

- 12.6.1. Exposing the TFT-LCD module to strong incident light may negatively affect the display characteristics because of polarizer film, color filter, and other materials degradation. Do not expose LCD module to direct sunlight or light with strong ultraviolet content.
- 12.6.2. Avoid any contact of the TFT-LCD module front surface with other objects or materials.
- 12.6.3. Packaging and shipping
 - 12.6.3.1. Packaging box and inner case for LCD are designed to protect the LCDs from the damage or scratching during transportation. Do not open the packaging box unnecessarily.
 - 12.6.3.2. Do not stack more than 5 boxes on top of each other because stack of 5 is maximum designed limit. Do not turn over the boxes.
 - 12.6.3.3. Avoid excessive shock, the shipping boxes are not designed to be thrown. Excessive vibrations can also damage the boxes and the TFT-LCD modules inside.
 - 12.6.3.4. Packaging box and the inner structures of it are made of cardboard. Avoid to have the boxes in contact with water or in high humidity environment which may cause the carton to become soft, or to break, damaging the TFT-LCD modules inside.

SIZE	MITSUBISHI ELECTRIC SPECIFICATION	REV.				
A	AA104VB04	A	SHEET	21	OF	21